

Alliant Engineering Inc Minneapolis, MN 55415

Prairie Center Dr at Singletree Lane
Eden Prairie
data by: Alliant Engineering
TURN MOVEMENT COUNT

File Name : 21_Prairie Center Drive at Singletree Lane
Site Code : 00000021
Start Date : 10/20/2009
Page No : 1

Groups Printed- Unshifted - Bank 1

Start Time	Prairie Center Drive Southbound				Singletree Lane Westbound				Prairie Center Drive Northbound				commercial entrance Eastbound				Int. Total	
	Left	Thru	Right	Peds	Left	Thru	Right	Peds	Left	Thru	Right	Peds	Left	Thru	Right	Peds		
06:30	13	49	3	1	0	3	17	0	1	71	1	0	0	0	0	0	0	159
06:45	17	65	10	0	0	2	16	0	2	146	1	0	6	1	2	0	0	268
Total	30	114	13	1	0	5	33	0	3	217	2	0	6	1	2	0	0	427
07:00	31	67	4	0	4	0	13	0	4	134	8	1	4	1	5	0	0	276
07:15	26	96	8	0	1	0	21	0	5	170	12	0	9	3	3	0	0	354
07:30	30	108	3	0	2	1	20	0	0	163	14	0	16	5	3	0	0	365
07:45	29	114	5	1	3	2	31	0	9	173	14	0	8	5	1	0	0	395
Total	116	385	20	1	10	3	85	0	18	640	48	1	37	14	12	0	0	1390
08:00	33	88	9	0	1	4	31	0	4	140	5	0	8	3	2	0	0	328
08:15	28	125	7	0	2	4	28	1	6	149	5	1	7	9	1	0	0	373
08:30	46	121	15	1	4	1	17	0	7	152	7	1	8	2	3	0	0	385
08:45	49	134	3	0	3	3	24	0	5	101	10	0	6	4	0	0	0	342
Total	156	468	34	1	10	12	100	1	22	542	27	2	29	18	6	0	0	1428
09:00	49	127	7	0	1	2	17	0	12	90	10	0	1	3	4	0	0	323
09:15	70	108	23	1	5	4	15	0	4	69	7	0	11	2	4	0	0	323
*** BREAK ***																		
Total	119	235	30	1	6	6	32	0	16	159	17	0	12	5	8	0	0	646
*** BREAK ***																		
10:30	77	136	8	2	2	4	25	0	3	126	5	0	13	11	7	0	0	419
10:45	65	146	6	0	1	3	48	0	2	117	7	0	19	4	3	0	0	421
Total	142	282	14	2	3	7	73	0	5	243	12	0	32	15	10	0	0	840
11:00	90	153	4	0	6	0	53	0	0	135	8	0	19	6	8	0	0	482
11:15	93	211	8	1	6	1	47	1	4	173	14	0	14	6	9	1	0	589
11:30	110	240	5	1	19	4	55	0	5	181	8	0	10	1	6	0	0	645
11:45	136	284	10	0	23	3	55	0	5	196	14	0	9	4	7	0	0	746
Total	429	888	27	2	54	8	210	1	14	685	44	0	52	17	30	1	0	2462
12:00	95	283	2	0	8	3	61	0	1	240	18	0	7	4	3	0	0	725
12:15	104	264	4	0	12	6	89	0	7	267	10	0	12	1	7	0	0	783
12:30	116	233	4	1	10	4	77	0	5	278	8	0	13	3	6	2	0	760
12:45	106	262	8	0	12	3	85	0	5	239	12	0	11	11	2	0	0	756
Total	421	1042	18	1	42	16	312	0	18	1024	48	0	43	19	18	2	0	3024
13:00	93	236	2	0	15	1	99	0	4	226	16	0	12	10	5	0	0	719
13:15	96	202	1	0	10	0	69	0	5	232	4	0	7	4	1	2	0	633
*** BREAK ***																		
Total	189	438	3	0	25	1	168	0	9	458	20	0	19	14	6	2	0	1352
*** BREAK ***																		
14:30	90	176	2	0	10	4	73	1	4	185	21	0	13	5	7	1	0	592
14:45	78	163	9	0	15	1	59	0	5	157	10	0	8	3	6	0	0	514
Total	168	339	11	0	25	5	132	1	9	342	31	0	21	8	13	1	0	1106
15:00	94	186	9	0	6	6	41	0	2	139	9	0	18	3	2	0	0	515
15:15	67	210	3	0	12	4	64	0	6	134	7	0	6	2	4	0	0	519
15:30	73	195	7	0	8	6	61	0	4	187	17	0	4	5	4	0	0	571
15:45	93	203	13	0	6	7	63	0	4	174	17	1	9	4	3	1	0	598
Total	327	794	32	0	32	23	229	0	16	634	50	1	37	14	13	1	0	2203
16:00	121	227	10	0	8	6	95	0	6	186	12	0	11	6	6	1	0	695
16:15	106	250	13	1	14	6	64	0	3	151	14	0	8	8	8	1	0	647
16:30	102	262	16	0	10	9	66	0	4	199	11	0	8	5	3	1	0	696
16:45	123	297	11	0	19	7	87	0	6	176	20	0	10	5	5	0	0	766
Total	452	1036	50	1	51	28	312	0	19	712	57	0	37	24	22	3	0	2804

Alliant Engineering Inc Minneapolis, MN 55415

Prairie Center Dr at Singletree Lane
Eden Prairie
data by: Alliant Engineering
TURN MOVEMENT COUNT

File Name : 21_Prairie Center Drive at Singletree Lane
Site Code : 00000021
Start Date : 10/20/2009
Page No : 2

Groups Printed- Unshifted - Bank 1

Start Time	Prairie Center Drive Southbound				Singletree Lane Westbound				Prairie Center Drive Northbound				commercial entrance Eastbound				Int. Total
	Left	Thru	Right	Peds	Left	Thru	Right	Peds	Left	Thru	Right	Peds	Left	Thru	Right	Peds	
17:00	97	260	14	1	17	10	91	0	4	182	12	0	14	7	15	0	724
17:15	119	312	8	0	17	8	79	0	4	191	27	0	8	4	2	0	779
17:30	121	275	8	0	19	6	102	0	9	195	25	0	6	5	3	0	774
17:45	125	292	25	0	36	12	104	0	5	174	15	0	20	7	4	2	821
Total	462	1139	55	1	89	36	376	0	22	742	79	0	48	23	24	2	3098
18:00	118	248	14	0	16	8	72	0	6	168	15	0	37	4	6	0	712
18:15	117	256	7	0	12	3	87	0	3	171	12	0	16	2	9	0	695
18:30	107	160	7	0	16	6	73	0	7	186	19	0	14	4	3	0	602
18:45	79	170	11	0	17	10	71	0	6	167	10	0	18	7	2	0	568
Total	421	834	39	0	61	27	303	0	22	692	56	0	85	17	20	0	2577
Grand Total	3432	7994	346	11	408	177	2365	3	193	7090	491	4	458	189	184	12	23357
Apprch %	29.1	67.8	2.9	0.1	13.8	6	80.1	0.1	2.5	91.2	6.3	0.1	54.3	22.4	21.8	1.4	
Total %	14.7	34.2	1.5	0	1.7	0.8	10.1	0	0.8	30.4	2.1	0	2	0.8	0.8	0.1	
Unshifted	3400	7836	344	11	394	176	2350	3	189	6983	484	4	451	186	182	12	23005
% Unshifted	99.1	98	99.4	100	96.6	99.4	99.4	100	97.9	98.5	98.6	100	98.5	98.4	98.9	100	98.5
Bank 1	32	158	2	0	14	1	15	0	4	107	7	0	7	3	2	0	352
% Bank 1	0.9	2	0.6	0	3.4	0.6	0.6	0	2.1	1.5	1.4	0	1.5	1.6	1.1	0	1.5

Alliant Engineering Inc Minneapolis, MN 55415

Prairie Center Dr at Singletree Lane
Eden Prairie
data by: Alliant Engineering
TURN MOVEMENT COUNT

File Name : 21_Prairie Center Drive at Singletree Lane
Site Code : 00000021
Start Date : 10/20/2009
Page No : 3

Start Time	Prairie Center Drive Southbound					Singletree Lane Westbound					Prairie Center Drive Northbound					commercial entrance Eastbound					Int. Total
	Left	Thru	Right	Peds	App. Total	Left	Thru	Right	Peds	App. Total	Left	Thru	Right	Peds	App. Total	Left	Thru	Right	Peds	App. Total	
Peak Hour Analysis From 06:30 to 09:15 - Peak 1 of 1																					
Peak Hour for Entire Intersection Begins at 07:45																					
07:45	29	114	5	1	149	3	2	31	0	36	9	173	14	0	196	8	5	1	0	14	395
08:00	33	88	9	0	130	1	4	31	0	36	4	140	5	0	149	8	3	2	0	13	328
08:15	28	125	7	0	160	2	4	28	1	35	6	149	5	1	161	7	9	1	0	17	373
08:30	46	121	15	1	183	4	1	17	0	22	7	152	7	1	167	8	2	3	0	13	385
Total Volume	136	448	36	2	622	10	11	107	1	129	26	614	31	2	673	31	19	7	0	57	1481
% App. Total	21.9	72	5.8	0.3		7.8	8.5	82.9	0.8		3.9	91.2	4.6	0.3		54.4	33.3	12.3	0		
PHF	.739	.896	.600	.500	.850	.625	.688	.863	.250	.896	.722	.887	.554	.500	.858	.969	.528	.583	.000	.838	.937

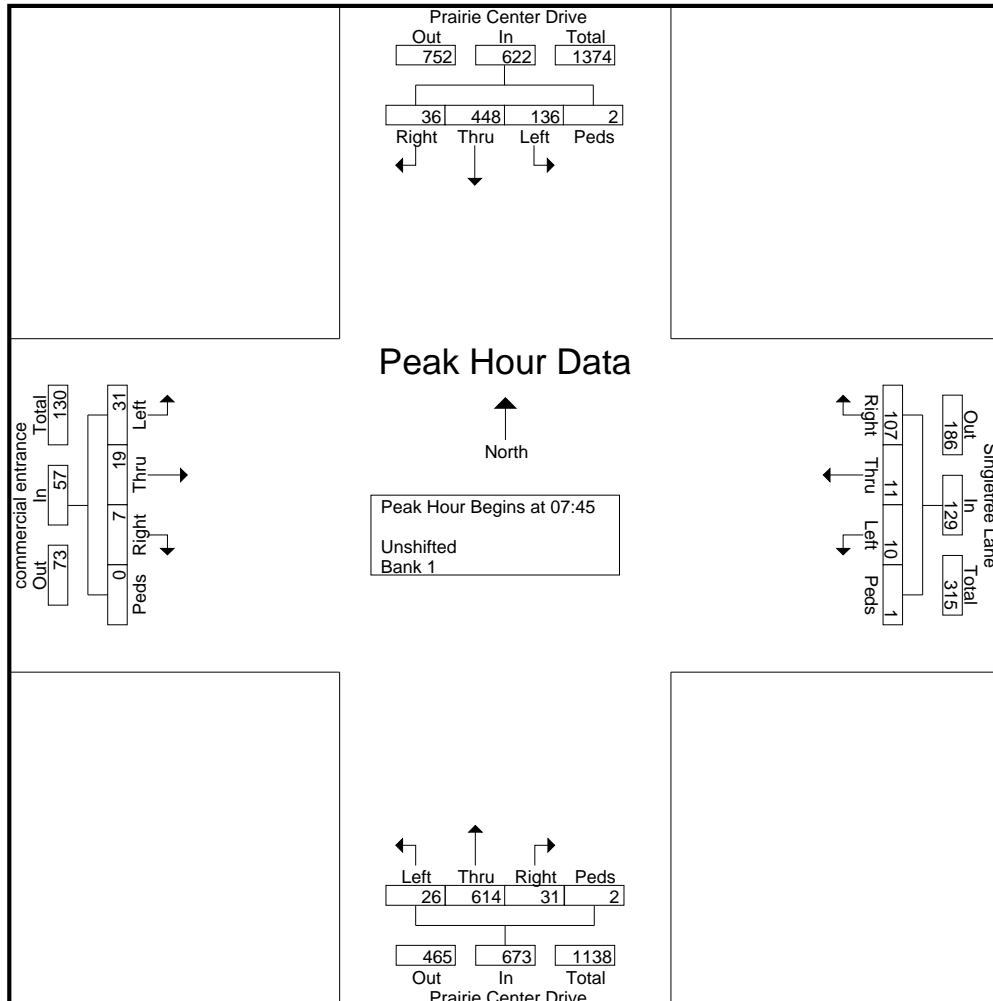

Alliant Engineering Inc Minneapolis, MN 55415

Prairie Center Dr at Singletree Lane
Eden Prairie
data by: Alliant Engineering
TURN MOVEMENT COUNT

File Name : 21_Prairie Center Drive at Singletree Lane
Site Code : 00000021
Start Date : 10/20/2009
Page No : 4

Start Time	Prairie Center Drive Southbound					Singletree Lane Westbound					Prairie Center Drive Northbound					commercial entrance Eastbound					Int. Total
	Left	Thru	Right	Peds	App. Total	Left	Thru	Right	Peds	App. Total	Left	Thru	Right	Peds	App. Total	Left	Thru	Right	Peds	App. Total	
Peak Hour Analysis From 14:30 to 18:45 - Peak 1 of 1																					
Peak Hour for Entire Intersection Begins at 17:00																					
17:00	97	260	14	1	372	17	10	91	0	118	4	182	12	0	198	14	7	15	0	36	724
17:15	119	312	8	0	439	17	8	79	0	104	4	191	27	0	222	8	4	2	0	14	779
17:30	121	275	8	0	404	19	6	102	0	127	9	195	25	0	229	6	5	3	0	14	774
17:45	125	292	25	0	442	36	12	104	0	152	5	174	15	0	194	20	7	4	2	33	821
Total Volume	462	1139	55	1	1657	89	36	376	0	501	22	742	79	0	843	48	23	24	2	97	3098
% App. Total	27.9	68.7	3.3	0.1		17.8	7.2	75	0		2.6	88	9.4	0		49.5	23.7	24.7	2.1		
PHF	.924	.913	.550	.250	.937	.618	.750	.904	.000	.824	.611	.951	.731	.000	.920	.600	.821	.400	.250	.674	.943

