



MINNESOTA DEPT OF TRANSPORTATION

TRAFFIC DATA COLLECTION - METRO

TH-212 at CSAH-51 (W of Cologne)

Ref.Pt.: 135.210

JAMAR # T-2638 CAH

TURN MOVEMENT COUNT

File Name : TH-212 at CSAH-51 2009

Site Code : 00000000

Start Date : 10/29/2009

Page No : 1

Groups Printed- Cars & Trucks

Start Time	CSAH-51 Southbound				TH-212 Westbound				CSAH-51 Northbound				TH-212 Eastbound				Int. Total
	Left	Thru	Right	Peds	Left	Thru	Right	Peds	Left	Thru	Right	Peds	Left	Thru	Right	Peds	
06:00	0	2	0	0	2	28	1	0	7	7	11	0	0	152	3	0	213
06:15	2	0	1	0	2	32	0	0	1	3	8	0	0	166	1	0	216
06:30	2	3	1	0	5	46	1	0	3	7	8	0	0	174	10	0	260
06:45	5	4	0	0	7	55	2	0	2	0	18	0	2	169	4	0	268
Total	9	9	2	0	16	161	4	0	13	17	45	0	2	661	18	0	957
07:00	3	2	0	0	6	55	0	0	2	3	18	0	2	150	0	0	241
07:15	1	3	4	0	4	51	3	0	0	11	12	0	3	200	3	0	295
07:30	9	2	0	0	4	73	5	0	3	3	12	0	0	176	5	0	292
07:45	5	1	0	0	7	65	5	0	7	7	7	0	3	137	5	0	249
Total	18	8	4	0	21	244	13	0	12	24	49	0	8	663	13	0	1077
08:00	5	4	0	0	4	42	3	0	2	4	4	0	1	107	8	0	184
08:15	5	3	1	0	5	41	2	0	3	2	1	0	0	105	2	0	170
08:30	3	1	0	0	1	53	0	0	3	7	4	0	1	81	4	0	158
08:45	2	3	2	0	2	52	1	0	6	5	4	0	2	85	3	0	167
Total	15	11	3	0	12	188	6	0	14	18	13	0	4	378	17	0	679
*** BREAK ***																	
15:00	4	2	1	0	6	117	4	0	5	2	3	0	7	95	4	0	250
15:15	1	6	1	0	4	120	1	0	2	5	4	0	3	84	10	0	241
15:30	0	6	1	0	9	132	8	0	9	5	4	0	0	81	6	0	261
15:45	2	7	6	0	6	154	1	0	4	4	3	0	2	78	5	0	272
Total	7	21	9	0	25	523	14	0	20	16	14	0	12	338	25	0	1024
16:00	6	6	3	0	12	111	4	0	13	4	6	0	3	59	6	0	233
16:15	2	2	1	0	6	135	7	0	9	2	5	0	0	68	3	0	240
16:30	1	3	3	0	6	163	3	0	4	6	9	0	0	82	6	0	286
16:45	6	10	1	0	10	155	4	0	9	2	3	0	5	75	8	0	288
Total	15	21	8	0	34	564	18	0	35	14	23	0	8	284	23	0	1047
17:00	3	6	3	0	14	175	2	0	7	5	4	0	0	90	3	0	312
17:15	1	6	0	0	7	139	7	0	6	4	5	0	0	91	1	0	267
17:30	3	5	1	0	9	144	1	0	6	3	4	0	1	78	1	0	256
17:45	6	7	1	0	9	117	2	0	4	3	7	0	1	67	2	0	226
Total	13	24	5	0	39	575	12	0	23	15	20	0	2	326	7	0	1061
Grand Total	77	94	31	0	147	2255	67	0	117	104	164	0	36	2650	103	0	5845
Apprch %	38.1	46.5	15.3	0	6	91.3	2.7	0	30.4	27	42.6	0	1.3	95	3.7	0	
Total %	1.3	1.6	0.5	0	2.5	38.6	1.1	0	2	1.8	2.8	0	0.6	45.3	1.8	0	



MINNESOTA DEPT OF TRANSPORTATION

TRAFFIC DATA COLLECTION - METRO

TH-212 at CSAH-51 (W of Cologne)
 Ref.Pt.: 135.210
 JAMAR # T-2638 CAH
 TURN MOVEMENT COUNT

File Name : TH-212 at CSAH-51 2009
 Site Code : 00000000
 Start Date : 10/29/2009
 Page No : 2

Start Time	CSAH-51 Southbound					TH-212 Westbound					CSAH-51 Northbound					TH-212 Eastbound					Int. Total
	Left	Thru	Right	Peds	App. Total	Left	Thru	Right	Peds	App. Total	Left	Thru	Right	Peds	App. Total	Left	Thru	Right	Peds	App. Total	
Peak Hour Analysis From 06:00 to 08:45 - Peak 1 of 1																					
Peak Hour for Entire Intersection Begins at 06:45																					
06:45	5	4	0	0	9	7	55	2	0	64	2	0	18	0	20	2	169	4	0	175	268
07:00	3	2	0	0	5	6	55	0	0	61	2	3	18	0	23	2	150	0	0	152	241
07:15	1	3	4	0	8	4	51	3	0	58	0	11	12	0	23	3	200	3	0	206	295
07:30	9	2	0	0	11	4	73	5	0	82	3	3	12	0	18	0	176	5	0	181	292
Total Volume	18	11	4	0	33	21	234	10	0	265	7	17	60	0	84	7	695	12	0	714	1096
% App. Total	54.5	33.3	12.1	0		7.9	88.3	3.8	0		8.3	20.2	71.4	0		1	97.3	1.7	0		
PHF	.500	.688	.250	.000	.750	.750	.801	.500	.000	.808	.583	.386	.833	.000	.913	.583	.869	.600	.000	.867	.929

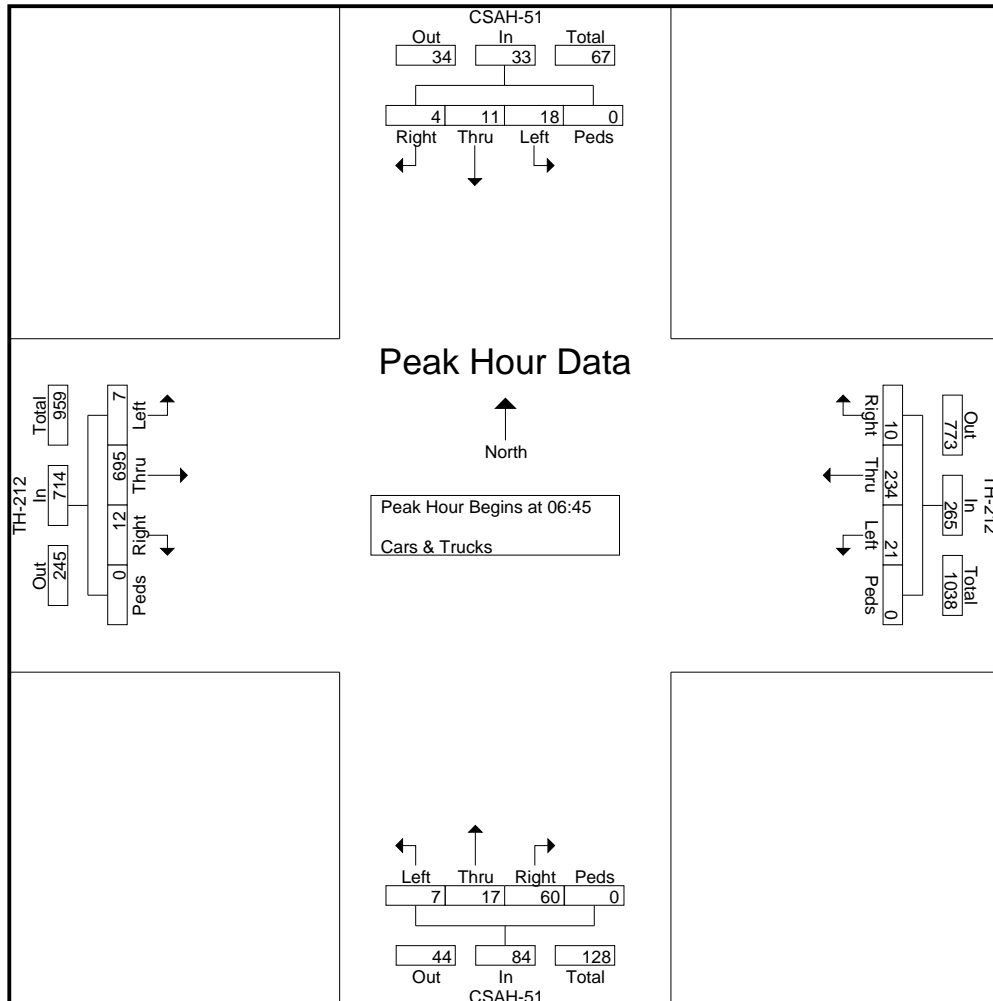



MINNESOTA DEPT OF TRANSPORTATION

TRAFFIC DATA COLLECTION - METRO

TH-212 at CSAH-51 (W of Cologne)
 Ref.Pt.: 135.210
 JAMAR # T-2638 CAH
 TURN MOVEMENT COUNT

File Name : TH-212 at CSAH-51 2009
 Site Code : 00000000
 Start Date : 10/29/2009
 Page No : 3

Start Time	CSAH-51 Southbound					TH-212 Westbound					CSAH-51 Northbound					TH-212 Eastbound					Int. Total
	Left	Thru	Right	Peds	App. Total	Left	Thru	Right	Peds	App. Total	Left	Thru	Right	Peds	App. Total	Left	Thru	Right	Peds	App. Total	
Peak Hour Analysis From 15:00 to 17:45 - Peak 1 of 1																					
Peak Hour for Entire Intersection Begins at 16:30																					
16:30	1	3	3	0	7	6	163	3	0	172	4	6	9	0	19	0	82	6	0	88	286
16:45	6	10	1	0	17	10	155	4	0	169	9	2	3	0	14	5	75	8	0	88	288
17:00	3	6	3	0	12	14	175	2	0	191	7	5	4	0	16	0	90	3	0	93	312
17:15	1	6	0	0	7	7	139	7	0	153	6	4	5	0	15	0	91	1	0	92	267
Total Volume	11	25	7	0	43	37	632	16	0	685	26	17	21	0	64	5	338	18	0	361	1153
% App. Total	25.6	58.1	16.3	0		5.4	92.3	2.3	0		40.6	26.6	32.8	0		1.4	93.6	5	0		
PHF	.458	.625	.583	.000	.632	.661	.903	.571	.000	.897	.722	.708	.583	.000	.842	.250	.929	.563	.000	.970	.924

