



# MINNESOTA DEPT OF TRANSPORTATION

## TRAFFIC DATA COLLECTION - METRO

TH-169 AT CSAH-81 2006  
 REF.PT.: 139+00.572  
 JAMAR # T-1385/MAR/RE  
 TURN MOVEMENT COUNT

File Name : TH 169 @ CSAH 81 2006  
 Site Code : 00000000  
 Start Date : 10/11/2006  
 Page No : 1

### Groups Printed- Cars & Trucks

Start Time	TH 169 Southbound				CSAH 81 Westbound				TH 169 Northbound				CSAH 81 Eastbound				Int. Total
	Left	Thru	Right	Peds	Left	Thru	Right	Peds	Left	Thru	Right	Peds	Left	Thru	Right	Peds	
06:00	27	498	1	0	3	51	18	0	20	147	6	0	0	87	160	0	1018
06:15	24	463	5	0	1	63	36	0	73	169	0	0	0	111	243	0	1188
06:30	28	496	0	0	3	83	57	0	99	196	0	0	0	172	264	0	1398
06:45	32	458	1	0	4	144	38	0	73	328	2	0	0	209	233	0	1522
Total	111	1915	7	0	11	341	149	0	265	840	8	0	0	579	900	0	5126
07:00	30	501	0	0	5	115	44	0	89	285	3	0	0	260	293	0	1625
07:15	68	447	3	0	7	94	37	0	41	402	6	0	0	241	263	0	1609
07:30	51	523	0	0	6	62	52	0	44	441	2	0	0	293	248	0	1722
07:45	57	430	0	0	4	88	52	0	71	434	4	0	0	250	282	0	1672
Total	206	1901	3	0	22	359	185	0	245	1562	15	0	0	1044	1086	0	6628
08:00	30	390	1	0	6	92	41	0	46	339	5	0	0	179	211	0	1340
08:15	50	474	1	0	3	82	47	0	53	343	2	0	0	199	234	0	1488
08:30	51	456	0	0	3	82	57	0	44	305	6	0	0	137	192	0	1333
08:45	47	444	3	0	3	63	52	0	90	373	5	0	0	123	174	0	1377
Total	178	1764	5	0	15	319	197	0	233	1360	18	0	0	638	811	0	5538
*** BREAK ***																	
11:00	68	282	1	0	10	71	86	0	56	274	5	0	0	67	66	0	986
11:15	50	290	2	0	12	102	66	0	94	249	9	0	0	109	75	0	1058
11:30	64	309	5	0	3	78	78	0	112	275	12	0	0	119	68	0	1123
11:45	48	307	2	0	9	110	65	0	61	383	8	0	0	114	108	0	1215
Total	230	1188	10	0	34	361	295	0	323	1181	34	0	0	409	317	0	4382
12:00	57	324	1	0	15	90	65	0	80	335	15	0	0	124	85	0	1191
12:15	56	342	2	0	5	98	73	0	59	329	11	0	0	128	58	0	1161
12:30	42	334	0	0	10	101	70	0	56	390	10	0	0	114	84	0	1211
12:45	68	330	1	0	11	89	57	0	82	380	7	0	0	96	104	0	1225
Total	223	1330	4	0	41	378	265	0	277	1434	43	0	0	462	331	0	4788
*** BREAK ***																	
15:00	43	400	0	0	9	117	114	0	64	482	5	0	0	136	128	0	1498
15:15	61	352	1	0	8	163	133	0	65	535	6	0	0	117	105	0	1546
15:30	39	331	1	0	7	138	94	0	58	445	8	0	0	121	132	0	1374
15:45	65	392	4	0	9	217	125	0	44	387	6	0	0	173	122	0	1544
Total	208	1475	6	0	33	635	466	0	231	1849	25	0	0	547	487	0	5962
16:00	43	308	0	0	12	257	97	0	101	462	12	0	0	106	100	2	1500
16:15	48	357	0	0	12	201	119	0	53	452	7	0	0	146	77	0	1472
16:30	57	386	0	0	18	217	120	0	36	488	6	0	0	130	114	0	1572
16:45	80	380	2	0	5	224	126	0	49	526	6	0	0	93	107	0	1598
Total	228	1431	2	0	47	899	462	0	239	1928	31	0	0	475	398	2	6142
17:00	52	429	1	0	13	207	132	0	60	476	3	0	0	153	110	0	1636
17:15	52	421	2	0	16	243	135	0	50	542	5	0	0	126	95	0	1687
17:30	50	333	0	0	12	209	123	0	82	572	4	0	0	111	104	0	1600
17:45	43	393	1	0	7	169	111	0	175	432	10	0	0	151	64	0	1556
Total	197	1576	4	0	48	828	501	0	367	2022	22	0	0	541	373	0	6479
Grand Total	1581	12580	41	0	251	4120	2520	0	2180	12176	196	0	0	4695	4703	2	45045
Apprch %	11.1	88.6	0.3	0	3.6	59.8	36.6	0	15	83.7	1.3	0	0	49.9	50	0	
Total %	3.5	27.9	0.1	0	0.6	9.1	5.6	0	4.8	27	0.4	0	0	10.4	10.4	0	



# MINNESOTA DEPT OF TRANSPORTATION

## TRAFFIC DATA COLLECTION - METRO

TH-169 AT CSAH-81 2006  
 REF.PT.: 139+00.572  
 JAMAR # T-1385/MAR/RE  
 TURN MOVEMENT COUNT

File Name : TH 169 @ CSAH 81 2006  
 Site Code : 00000000  
 Start Date : 10/11/2006  
 Page No : 2

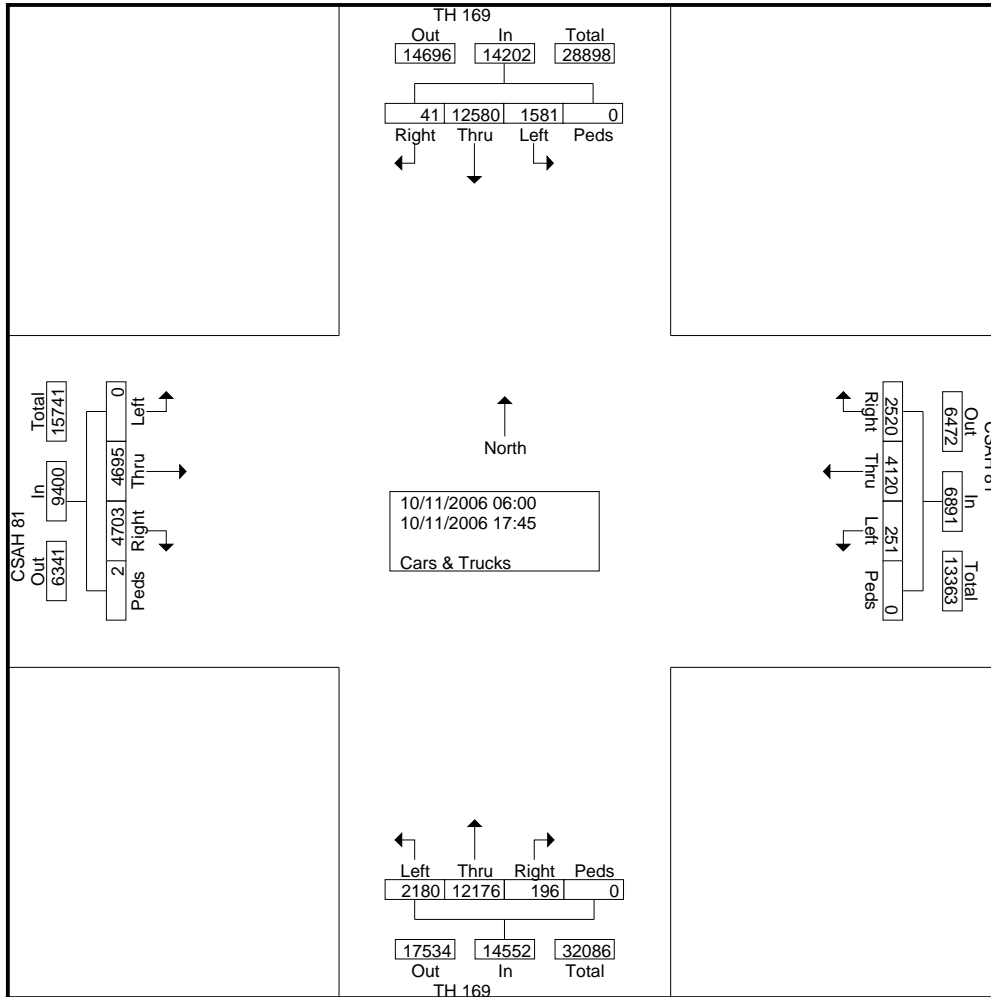



# MINNESOTA DEPT OF TRANSPORTATION

## TRAFFIC DATA COLLECTION - METRO

TH-169 AT CSAH-81 2006  
 REF.PT.: 139+00.572  
 JAMAR # T-1385/MAR/RE  
 TURN MOVEMENT COUNT

File Name : TH 169 @ CSAH 81 2006  
 Site Code : 00000000  
 Start Date : 10/11/2006  
 Page No : 3

Start Time	TH 169 Southbound					CSAH 81 Westbound					TH 169 Northbound					CSAH 81 Eastbound					Int. Total
	Left	Thru	Right	Peds	App. Total	Left	Thru	Right	Peds	App. Total	Left	Thru	Right	Peds	App. Total	Left	Thru	Right	Peds	App. Total	
Peak Hour Analysis From 06:00 to 12:00 - Peak 1 of 1																					
Peak Hour for Entire Intersection Begins at 07:00																					
07:00	30	501	0	0	531	5	<b>115</b>	44	0	<b>164</b>	<b>89</b>	285	3	0	377	0	260	<b>293</b>	0	<b>553</b>	1625
07:15	<b>68</b>	447	<b>3</b>	0	518	<b>7</b>	94	37	0	138	41	402	<b>6</b>	0	449	0	241	263	0	504	1609
07:30	51	<b>523</b>	0	0	<b>574</b>	6	62	<b>52</b>	0	120	44	<b>441</b>	2	0	487	0	<b>293</b>	248	0	541	<b>1722</b>
07:45	57	430	0	0	487	4	88	52	0	144	71	434	4	0	<b>509</b>	0	250	282	0	532	1672
Total Volume	206	1901	3	0	2110	22	359	185	0	566	245	1562	15	0	1822	0	1044	1086	0	2130	6628
% App. Total	<b>9.8</b>	90.1	<b>0.1</b>	0		<b>3.9</b>	63.4	32.7	0		<b>13.4</b>	85.7	<b>0.8</b>	0		0	49	51	0		
PHF	.757	.909	.250	.000	.919	.786	.780	.889	.000	.863	.688	.885	.625	.000	.895	.000	.891	.927	.000	.963	.962

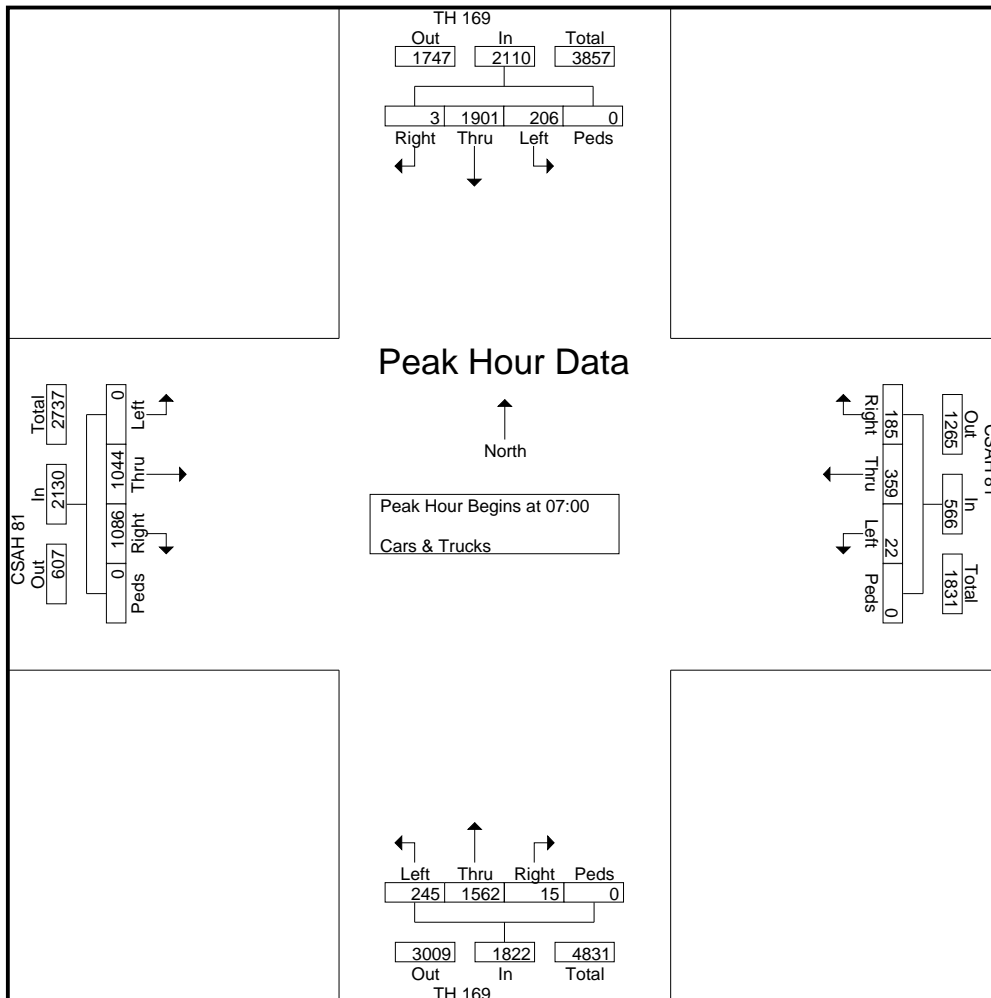



# MINNESOTA DEPT OF TRANSPORTATION

## TRAFFIC DATA COLLECTION - METRO

TH-169 AT CSAH-81 2006  
 REF.PT.: 139+00.572  
 JAMAR # T-1385/MAR/RE  
 TURN MOVEMENT COUNT

File Name : TH 169 @ CSAH 81 2006  
 Site Code : 00000000  
 Start Date : 10/11/2006  
 Page No : 4

Start Time	TH 169 Southbound					CSAH 81 Westbound					TH 169 Northbound					CSAH 81 Eastbound					Int. Total
	Left	Thru	Right	Peds	App. Total	Left	Thru	Right	Peds	App. Total	Left	Thru	Right	Peds	App. Total	Left	Thru	Right	Peds	App. Total	
Peak Hour Analysis From 12:15 to 17:45 - Peak 1 of 1																					
Peak Hour for Entire Intersection Begins at 16:45																					
16:45	80	380	2	0	462	5	224	126	0	355	49	526	6	0	581	0	93	107	0	200	1598
17:00	52	429	1	0	482	13	207	132	0	352	60	476	3	0	539	0	153	110	0	263	1636
17:15	52	421	2	0	475	16	243	135	0	394	50	542	5	0	597	0	126	95	0	221	1687
17:30	50	333	0	0	383	12	209	123	0	344	82	572	4	0	658	0	111	104	0	215	1600
Total Volume	234	1563	5	0	1802	46	883	516	0	1445	241	2116	18	0	2375	0	483	416	0	899	6521
% App. Total	13	86.7	0.3	0		3.2	61.1	35.7	0		10.1	89.1	0.8	0		0	53.7	46.3	0		
PHF	.731	.911	.625	.000	.935	.719	.908	.956	.000	.917	.735	.925	.750	.000	.902	.000	.789	.945	.000	.855	.966

