



# MINNESOTA DEPT OF TRANSPORTATION

## TRAFFIC DATA COLLECTION - METRO

TH-169 at CSAH-83 / Canterbury Rd S File Name : TH-169 at CSAH-83 Canterbury Rd South Ramp 2012  
 Ref.Pt.: 112,709 Site Code : 00000000  
 JAMAR # D4-3365 SP Start Date : 7/18/2012  
 TURN MOVEMENT COUNT Page No : 1

### Groups Printed- Cars & Trucks

Start Time	CSAH-83 / Canterbury Rd S Southbound				ramp to TH-169 EB Westbound				CSAH-83 / Canterbury Rd S Northbound				ramp from TH-169 EB Eastbound				Int. Total
	Left	Thru	Right	Peds	Left	Thru	Right	Peds	Left	Thru	Right	Peds	Left	Thru	Right	Peds	
06:00	17	42	0	0	0	0	0	0	0	36	113	0	46	0	5	0	259
06:15	22	59	0	0	0	0	0	0	0	54	154	0	60	0	5	0	354
06:30	26	64	0	0	0	0	0	0	0	70	222	0	89	0	9	0	480
06:45	20	56	0	0	0	0	0	0	0	109	242	0	82	0	8	0	517
Total	85	221	0	0	0	0	0	0	0	269	731	0	277	0	27	0	1610
07:00	32	72	0	0	0	0	0	0	0	99	261	0	46	0	25	0	535
07:15	44	63	0	0	0	0	0	1	0	84	253	1	52	0	16	0	514
07:30	27	107	0	1	0	0	0	0	0	118	215	1	60	0	21	0	550
07:45	30	101	0	0	0	0	0	0	0	163	206	0	84	0	36	0	620
Total	133	343	0	1	0	0	0	1	0	464	935	2	242	0	98	0	2219
08:00	23	91	0	0	0	0	0	0	0	98	185	2	57	0	33	0	489
08:15	34	92	0	0	0	0	0	0	0	70	151	0	38	0	30	0	415
08:30	33	95	0	0	0	0	0	0	0	85	148	1	39	1	29	0	431
08:45	32	133	0	0	0	0	0	0	0	70	120	0	39	0	25	0	419
Total	122	411	0	0	0	0	0	0	0	323	604	3	173	1	117	0	1754
*** BREAK ***																	
11:30	77	167	0	0	0	0	0	0	0	76	96	0	26	1	15	0	458
11:45	46	191	0	0	0	0	0	0	0	73	96	0	35	0	22	0	463
Total	123	358	0	0	0	0	0	0	0	149	192	0	61	1	37	0	921
12:00	57	181	0	0	0	0	0	0	0	95	121	1	35	1	17	0	508
12:15	65	185	0	0	0	0	0	0	0	95	101	1	44	0	29	0	520
12:30	51	173	0	0	0	0	0	0	0	85	100	1	35	0	27	0	472
12:45	45	173	0	1	0	0	0	0	0	93	99	0	39	0	33	1	484
Total	218	712	0	1	0	0	0	0	0	368	421	3	153	1	106	1	1984
13:00	59	181	0	0	0	0	0	0	0	74	109	1	32	1	23	0	480
13:15	60	183	0	0	0	0	0	0	0	77	130	0	24	0	11	0	485
*** BREAK ***																	
Total	119	364	0	0	0	0	0	0	0	151	239	1	56	1	34	0	965
*** BREAK ***																	
15:00	83	215	0	0	0	0	0	0	0	51	140	1	24	0	24	0	538
15:15	81	237	0	0	0	0	0	0	0	79	158	0	25	0	17	0	597
15:30	94	270	0	0	0	0	0	0	0	71	147	0	18	1	32	0	633
15:45	98	263	0	0	0	0	0	0	0	79	125	1	25	0	15	0	606
Total	356	985	0	0	0	0	0	0	0	280	570	2	92	1	88	0	2374
16:00	90	291	0	0	0	0	0	0	0	63	143	0	17	0	23	0	627
16:15	91	279	0	0	0	0	0	0	0	76	154	0	19	0	25	0	644
16:30	106	354	0	0	0	0	0	0	0	71	157	0	21	0	21	0	730
16:45	96	340	0	0	0	0	0	0	0	67	141	0	19	0	27	1	691
Total	383	1264	0	0	0	0	0	0	0	277	595	0	76	0	96	1	2692
17:00	143	382	0	1	0	0	0	0	0	68	139	1	15	1	18	0	768
17:15	97	354	0	0	0	0	0	0	0	63	119	1	16	1	25	0	676
17:30	102	257	0	0	0	0	0	0	0	73	121	1	18	1	29	0	602
17:45	79	297	0	0	0	0	0	0	0	66	127	0	29	0	27	0	625
Total	421	1290	0	1	0	0	0	0	0	270	506	3	78	3	99	0	2671
Grand Total	1960	5948	0	3	0	0	0	1	0	2551	4793	14	1208	8	702	2	17190
Apprch %	24.8	75.2	0	0	0	0	0	100	0	34.7	65.1	0.2	62.9	0.4	36.6	0.1	
Total %	11.4	34.6	0	0	0	0	0	0	0	14.8	27.9	0.1	7	0	4.1	0	





# MINNESOTA DEPT OF TRANSPORTATION

## TRAFFIC DATA COLLECTION - METRO

TH-169 at CSAH-83 / Canterbury Rd S File Name : TH-169 at CSAH-83 Canterbury Rd South Ramp 2012  
 Ref.Pt.: 112,709 Site Code : 00000000  
 JAMAR # D4-3365 SP Start Date : 7/18/2012  
 TURN MOVEMENT COUNT Page No : 3

Start Time	CSAH-83 / Canterbury Rd S Southbound					ramp to TH-169 EB Westbound					CSAH-83 / Canterbury Rd S Northbound					ramp from TH-169 EB Eastbound					Int. Total
	Left	Thru	Right	Peds	App. Total	Left	Thru	Right	Peds	App. Total	Left	Thru	Right	Peds	App. Total	Left	Thru	Right	Peds	App. Total	
Peak Hour Analysis From 06:00 to 08:45 - Peak 1 of 1																					
Peak Hour for Entire Intersection Begins at 07:00																					
07:00	32	72	0	0	104	0	0	0	0	0	0	99	261	0	360	46	0	25	0	71	535
07:15	44	63	0	0	107	0	0	0	1	1	0	84	253	1	338	52	0	16	0	68	514
07:30	27	107	0	1	135	0	0	0	0	0	0	118	215	1	334	60	0	21	0	81	550
07:45	30	101	0	0	131	0	0	0	0	0	0	163	206	0	369	84	0	36	0	120	620
Total Volume	133	343	0	1	477	0	0	0	1	1	0	464	935	2	1401	242	0	98	0	340	2219
% App. Total	27.9	71.9	0	0.2		0	0	0	100		0	33.1	66.7	0.1		71.2	0	28.8	0		
PHF	.756	.801	.000	.250	.883	.000	.000	.000	.250	.250	.000	.712	.896	.500	.949	.720	.000	.681	.000	.708	.895

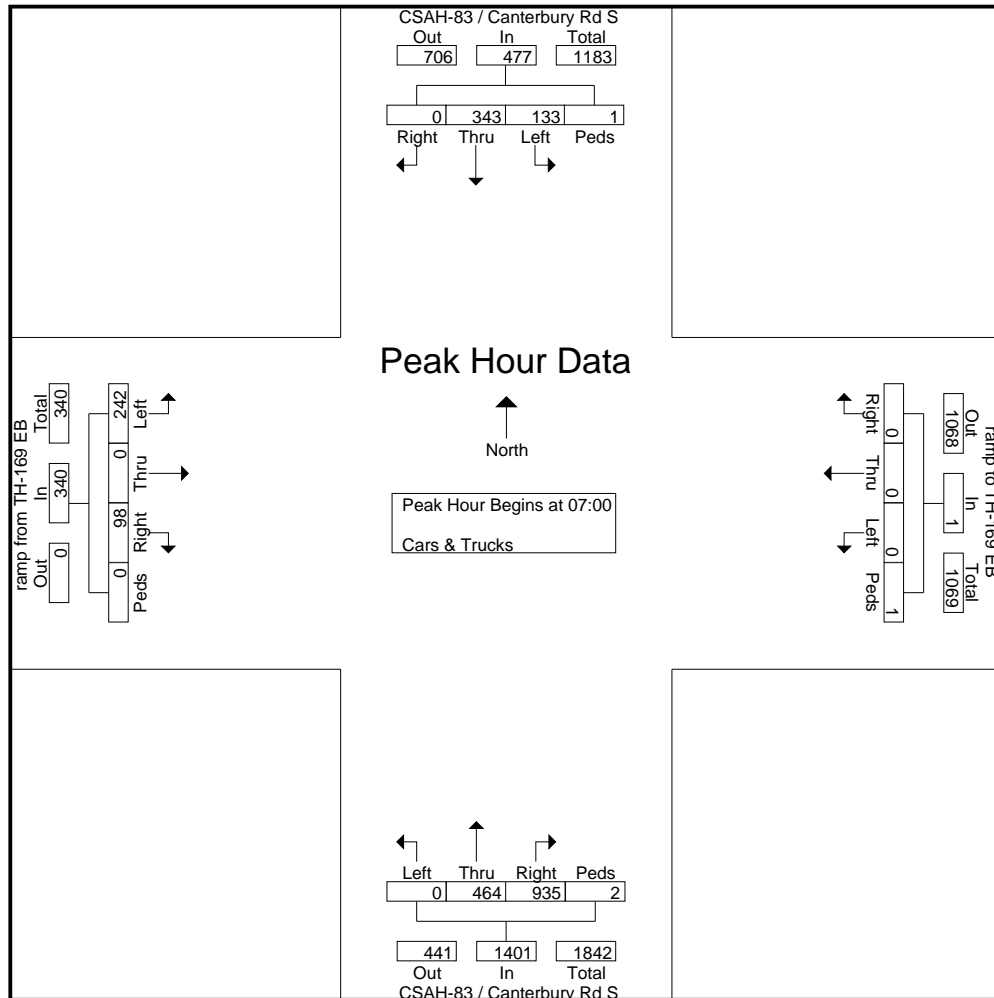



# MINNESOTA DEPT OF TRANSPORTATION

TRAFFIC DATA COLLECTION - METRO

TH-169 at CSAH-83 / Canterbury Rd S File Name : TH-169 at CSAH-83 Canterbury Rd South Ramp 2012  
 Ref.Pt.: 112,709 Site Code : 00000000  
 JAMAR # D4-3365 SP Start Date : 7/18/2012  
 TURN MOVEMENT COUNT Page No : 4

Start Time	CSAH-83 / Canterbury Rd S Southbound					ramp to TH-169 EB Westbound					CSAH-83 / Canterbury Rd S Northbound					ramp from TH-169 EB Eastbound					Int. Total
	Left	Thru	Right	Peds	App. Total	Left	Thru	Right	Peds	App. Total	Left	Thru	Right	Peds	App. Total	Left	Thru	Right	Peds	App. Total	
12:00	57	181	0	0	238	0	0	0	0	0	0	95	121	1	217	35	1	17	0	53	508
12:15	65	185	0	0	250	0	0	0	0	0	0	95	101	1	197	44	0	29	0	73	520
12:30	51	173	0	0	224	0	0	0	0	0	0	85	100	1	186	35	0	27	0	62	472
12:45	45	173	0	1	219	0	0	0	0	0	0	93	99	0	192	39	0	33	1	73	484
Total Volume	218	712	0	1	931	0	0	0	0	0	0	368	421	3	792	153	1	106	1	261	1984
% App. Total	23.4	76.5	0	0.1		0	0	0	0	0	0	46.5	53.2	0.4		58.6	0.4	40.6	0.4		
PHF	.838	.962	.000	.250	.931	.000	.000	.000	.000	.000	.000	.968	.870	.750	.912	.869	.250	.803	.250	.894	.954

Peak Hour Analysis From 11:30 to 13:15 - Peak 1 of 1  
 Peak Hour for Entire Intersection Begins at 12:00

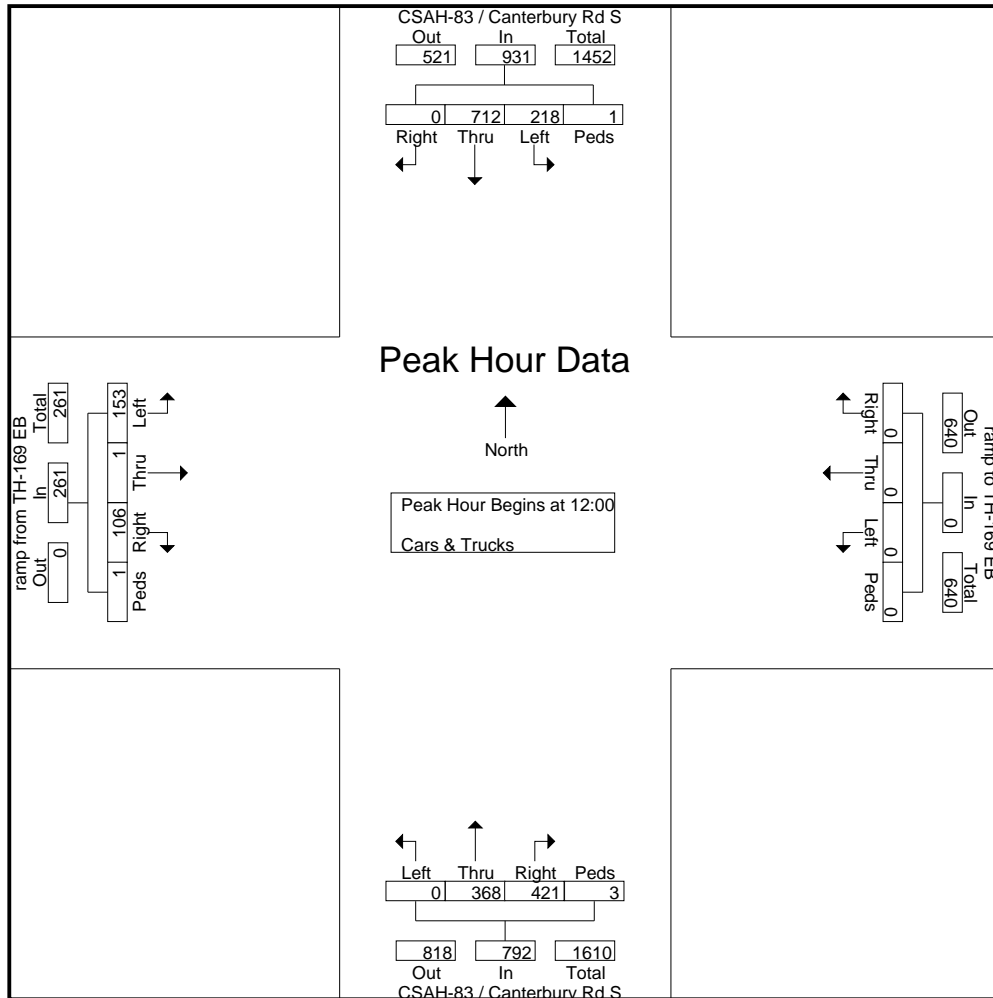



# MINNESOTA DEPT OF TRANSPORTATION

## TRAFFIC DATA COLLECTION - METRO

TH-169 at CSAH-83 / Canterbury Rd S File Name : TH-169 at CSAH-83 Canterbury Rd South Ramp 2012  
 Ref.Pt.: 112,709 Site Code : 00000000  
 JAMAR # D4-3365 SP Start Date : 7/18/2012  
 TURN MOVEMENT COUNT Page No : 5

Start Time	CSAH-83 / Canterbury Rd S Southbound					ramp to TH-169 EB Westbound					CSAH-83 / Canterbury Rd S Northbound					ramp from TH-169 EB Eastbound					Int. Total
	Left	Thru	Right	Peds	App. Total	Left	Thru	Right	Peds	App. Total	Left	Thru	Right	Peds	App. Total	Left	Thru	Right	Peds	App. Total	
16:30	106	354	0	0	460	0	0	0	0	0	0	71	157	0	228	21	0	21	0	42	730
16:45	96	340	0	0	436	0	0	0	0	0	0	67	141	0	208	19	0	27	1	47	691
17:00	143	382	0	1	526	0	0	0	0	0	0	68	139	1	208	15	1	18	0	34	768
17:15	97	354	0	0	451	0	0	0	0	0	0	63	119	1	183	16	1	25	0	42	676
Total Volume	442	1430	0	1	1873	0	0	0	0	0	0	269	556	2	827	71	2	91	1	165	2865
% App. Total	23.6	76.3	0	0.1		0	0	0	0	0	0	32.5	67.2	0.2		43	1.2	55.2	0.6		
PHF	.773	.936	.000	.250	.890	.000	.000	.000	.000	.000	.000	.947	.885	.500	.907	.845	.500	.843	.250	.878	.933

Peak Hour Analysis From 15:00 to 17:45 - Peak 1 of 1  
 Peak Hour for Entire Intersection Begins at 16:30

