

Traffic TURN MOVEMENT COUNT

CSAH-83 / Canterbury Rd S at 12th Ave E
 Ref: Pt.: Shakopee
 Data by: Scott County
 TURN MOVEMENT COUNT

File Name : CSAH-83 Canterbury Rd at 12th Ave 2012
 Site Code : 00000000
 Start Date : 7/25/2012
 Page No : 1

Groups Printed- Unshifted

| Start Time | CSAH-83 / Canterbury Rd S Southbound | | | | 12th Ave E Westbound | | | | CSAH-83 / Canterbury Rd S Northbound | | | | 12th Ave E Eastbound | | | | Int. Total |
|----------------------|--------------------------------------|------------|-----------|----------|----------------------|------------|-----------|----------|--------------------------------------|------------|------------|----------|----------------------|-----------|-----------|----------|-------------|
| | Left | Thru | Right | Peds | Left | Thru | Right | Peds | Left | Thru | Right | Peds | Left | Thru | Right | Peds | |
| 06:15 | 7 | 12 | 2 | 0 | 12 | 6 | 2 | 0 | 39 | 77 | 53 | 0 | 4 | 3 | 4 | 0 | 221 |
| 06:30 | 6 | 10 | 3 | 0 | 17 | 7 | 2 | 0 | 37 | 108 | 61 | 0 | 16 | 15 | 2 | 0 | 284 |
| 06:45 | 9 | 19 | 1 | 0 | 14 | 5 | 2 | 0 | 40 | 118 | 106 | 0 | 24 | 9 | 4 | 0 | 351 |
| Total | 22 | 41 | 6 | 0 | 43 | 18 | 6 | 0 | 116 | 303 | 220 | 0 | 44 | 27 | 10 | 0 | 856 |
| 07:00 | 12 | 51 | 7 | 0 | 24 | 7 | 2 | 0 | 34 | 66 | 75 | 0 | 6 | 7 | 8 | 0 | 299 |
| 07:15 | 3 | 20 | 5 | 0 | 25 | 10 | 3 | 0 | 54 | 76 | 87 | 0 | 9 | 12 | 7 | 0 | 311 |
| 07:30 | 8 | 15 | 7 | 0 | 16 | 9 | 3 | 0 | 59 | 102 | 98 | 0 | 11 | 16 | 5 | 0 | 349 |
| 07:45 | 11 | 22 | 7 | 0 | 19 | 7 | 3 | 0 | 79 | 137 | 111 | 0 | 25 | 26 | 4 | 0 | 451 |
| Total | 34 | 108 | 26 | 0 | 84 | 33 | 11 | 0 | 226 | 381 | 371 | 0 | 51 | 61 | 24 | 0 | 1410 |
| 08:00 | 17 | 38 | 4 | 0 | 26 | 7 | 2 | 0 | 50 | 89 | 88 | 0 | 7 | 26 | 10 | 0 | 364 |
| 08:15 | 5 | 24 | 13 | 0 | 23 | 1 | 7 | 0 | 67 | 61 | 53 | 0 | 12 | 10 | 7 | 1 | 284 |
| 08:30 | 12 | 26 | 4 | 0 | 18 | 10 | 0 | 0 | 77 | 55 | 24 | 0 | 13 | 3 | 9 | 0 | 251 |
| 08:45 | 2 | 17 | 5 | 0 | 16 | 1 | 1 | 0 | 77 | 67 | 46 | 0 | 10 | 11 | 8 | 0 | 261 |
| Total | 36 | 105 | 26 | 0 | 83 | 19 | 10 | 0 | 271 | 272 | 211 | 0 | 42 | 50 | 34 | 1 | 1160 |
| 09:00 | 4 | 33 | 11 | 0 | 16 | 4 | 7 | 0 | 57 | 69 | 32 | 0 | 11 | 10 | 4 | 0 | 258 |
| *** BREAK *** | | | | | | | | | | | | | | | | | |
| Total | 4 | 33 | 11 | 0 | 16 | 4 | 7 | 0 | 57 | 69 | 32 | 0 | 11 | 10 | 4 | 0 | 258 |
| *** BREAK *** | | | | | | | | | | | | | | | | | |
| 11:00 | 8 | 57 | 18 | 0 | 40 | 15 | 2 | 0 | 21 | 46 | 30 | 0 | 6 | 13 | 16 | 0 | 272 |
| 11:15 | 10 | 61 | 11 | 0 | 39 | 13 | 1 | 0 | 48 | 65 | 48 | 1 | 20 | 16 | 22 | 0 | 355 |
| 11:30 | 16 | 53 | 20 | 0 | 62 | 22 | 3 | 0 | 42 | 43 | 24 | 0 | 13 | 12 | 20 | 0 | 330 |
| 11:45 | 6 | 70 | 21 | 0 | 56 | 23 | 4 | 0 | 25 | 44 | 34 | 0 | 11 | 26 | 16 | 0 | 336 |
| Total | 40 | 241 | 70 | 0 | 197 | 73 | 10 | 0 | 136 | 198 | 136 | 1 | 50 | 67 | 74 | 0 | 1293 |
| 12:00 | 24 | 79 | 25 | 0 | 59 | 29 | 5 | 0 | 45 | 62 | 44 | 0 | 16 | 26 | 14 | 0 | 428 |
| 12:15 | 15 | 66 | 23 | 0 | 59 | 29 | 9 | 0 | 51 | 43 | 75 | 0 | 17 | 23 | 10 | 0 | 420 |
| 12:30 | 22 | 63 | 26 | 0 | 64 | 39 | 7 | 0 | 59 | 63 | 79 | 0 | 8 | 26 | 22 | 0 | 478 |
| 12:45 | 16 | 52 | 13 | 0 | 64 | 24 | 17 | 0 | 38 | 69 | 74 | 0 | 22 | 22 | 27 | 0 | 438 |
| Total | 77 | 260 | 87 | 0 | 246 | 121 | 38 | 0 | 193 | 237 | 272 | 0 | 63 | 97 | 73 | 0 | 1764 |
| *** BREAK *** | | | | | | | | | | | | | | | | | |
| 15:00 | 8 | 128 | 22 | 0 | 57 | 4 | 4 | 0 | 30 | 49 | 25 | 0 | 4 | 11 | 20 | 0 | 362 |
| 15:15 | 9 | 84 | 8 | 0 | 63 | 10 | 7 | 0 | 22 | 46 | 42 | 2 | 5 | 4 | 25 | 0 | 327 |
| 15:30 | 9 | 119 | 9 | 0 | 88 | 10 | 8 | 0 | 30 | 22 | 32 | 0 | 6 | 14 | 22 | 0 | 369 |
| 15:45 | 7 | 80 | 7 | 0 | 79 | 16 | 3 | 0 | 28 | 48 | 20 | 0 | 9 | 9 | 27 | 0 | 333 |
| Total | 33 | 411 | 46 | 0 | 287 | 40 | 22 | 0 | 110 | 165 | 119 | 2 | 24 | 38 | 94 | 0 | 1391 |
| 16:00 | 4 | 108 | 10 | 0 | 84 | 12 | 5 | 0 | 43 | 32 | 32 | 0 | 5 | 2 | 40 | 0 | 377 |

Traffic TURN MOVEMENT COUNT

CSAH-83 / Canterbury Rd S at 12th Ave E
 Ref: Pt.: Shakopee
 Data by: Scott County
 TURN MOVEMENT COUNT

File Name : CSAH-83 Canterbury Rd at 12th Ave 2012
 Site Code : 00000000
 Start Date : 7/25/2012
 Page No : 2

Groups Printed- Unshifted

| Start Time | CSAH-83 / Canterbury Rd S Southbound | | | | 12th Ave E Westbound | | | | CSAH-83 / Canterbury Rd S Northbound | | | | 12th Ave E Eastbound | | | | Int. Total |
|--------------------|--------------------------------------|-------------|------------|----------|----------------------|-------------|------------|----------|--------------------------------------|-------------|-------------|------------|----------------------|-------------|-------------|------------|--------------|
| | Left | Thru | Right | Peds | Left | Thru | Right | Peds | Left | Thru | Right | Peds | Left | Thru | Right | Peds | |
| 16:15 | 8 | 77 | 11 | 0 | 65 | 12 | 8 | 0 | 20 | 39 | 21 | 0 | 15 | 5 | 39 | 0 | 320 |
| 16:30 | 11 | 143 | 14 | 0 | 125 | 18 | 10 | 0 | 33 | 44 | 32 | 0 | 4 | 9 | 52 | 0 | 495 |
| 16:45 | 7 | 111 | 12 | 0 | 91 | 10 | 7 | 0 | 56 | 38 | 22 | 1 | 2 | 5 | 27 | 0 | 389 |
| Total | 30 | 439 | 47 | 0 | 365 | 52 | 30 | 0 | 152 | 153 | 107 | 1 | 26 | 21 | 158 | 0 | 1581 |
| 17:00 | 4 | 106 | 14 | 0 | 117 | 28 | 5 | 0 | 46 | 29 | 25 | 0 | 6 | 9 | 43 | 0 | 432 |
| 17:15 | 8 | 95 | 15 | 0 | 97 | 11 | 10 | 0 | 44 | 38 | 35 | 0 | 7 | 10 | 35 | 0 | 405 |
| 17:30 | 9 | 73 | 12 | 0 | 62 | 20 | 5 | 0 | 53 | 36 | 22 | 0 | 5 | 13 | 33 | 0 | 343 |
| 17:45 | 11 | 54 | 11 | 0 | 75 | 13 | 9 | 0 | 47 | 25 | 44 | 0 | 1 | 7 | 29 | 0 | 326 |
| Total | 32 | 328 | 52 | 0 | 351 | 72 | 29 | 0 | 190 | 128 | 126 | 0 | 19 | 39 | 140 | 0 | 1506 |
| Grand Total | 308 | 1966 | 371 | 0 | 1672 | 432 | 163 | 0 | 1451 | 1906 | 1594 | 4 | 330 | 410 | 611 | 1 | 11219 |
| Apprch % | 11.6 | 74.3 | 14 | 0 | 73.8 | 19.1 | 7.2 | 0 | 29.3 | 38.5 | 32.2 | 0.1 | 24.4 | 30.3 | 45.2 | 0.1 | |
| Total % | 2.7 | 17.5 | 3.3 | 0 | 14.9 | 3.9 | 1.5 | 0 | 12.9 | 17 | 14.2 | 0 | 2.9 | 3.7 | 5.4 | 0 | |

Traffic TURN MOVEMENT COUNT

CSAH-83 / Canterbury Rd S at 12th Ave E
 Ref: Pt.: Shakopee
 Data by: Scott County
 TURN MOVEMENT COUNT

File Name : CSAH-83 Canterbury Rd at 12th Ave 2012
 Site Code : 00000000
 Start Date : 7/25/2012
 Page No : 3

| Start Time | CSAH-83 / Canterbury Rd S Southbound | | | | | 12th Ave E Westbound | | | | | CSAH-83 / Canterbury Rd S Northbound | | | | | 12th Ave E Eastbound | | | | | Int. Total |
|---|--------------------------------------|------|-------|------|------------|----------------------|------|-------|------|------------|--------------------------------------|------|-------|------|------------|----------------------|------|-------|------|------------|------------|
| | Left | Thru | Right | Peds | App. Total | Left | Thru | Right | Peds | App. Total | Left | Thru | Right | Peds | App. Total | Left | Thru | Right | Peds | App. Total | |
| Peak Hour Analysis From 06:15 to 09:00 - Peak 1 of 1 | | | | | | | | | | | | | | | | | | | | | |
| Peak Hour for Entire Intersection Begins at 07:15 | | | | | | | | | | | | | | | | | | | | | |
| 07:15 | 3 | 20 | 5 | 0 | 28 | 25 | 10 | 3 | 0 | 38 | 54 | 76 | 87 | 0 | 217 | 9 | 12 | 7 | 0 | 28 | 311 |
| 07:30 | 8 | 15 | 7 | 0 | 30 | 16 | 9 | 3 | 0 | 28 | 59 | 102 | 98 | 0 | 259 | 11 | 16 | 5 | 0 | 32 | 349 |
| 07:45 | 11 | 22 | 7 | 0 | 40 | 19 | 7 | 3 | 0 | 29 | 79 | 137 | 111 | 0 | 327 | 25 | 26 | 4 | 0 | 55 | 451 |
| 08:00 | 17 | 38 | 4 | 0 | 59 | 26 | 7 | 2 | 0 | 35 | 50 | 89 | 88 | 0 | 227 | 7 | 26 | 10 | 0 | 43 | 364 |
| Total Volume | 39 | 95 | 23 | 0 | 157 | 86 | 33 | 11 | 0 | 130 | 242 | 404 | 384 | 0 | 1030 | 52 | 80 | 26 | 0 | 158 | 1475 |
| % App. Total | 24.8 | 60.5 | 14.6 | 0 | | 66.2 | 25.4 | 8.5 | 0 | | 23.5 | 39.2 | 37.3 | 0 | | 32.9 | 50.6 | 16.5 | 0 | | |
| PHF | .574 | .625 | .821 | .000 | .665 | .827 | .825 | .917 | .000 | .855 | .766 | .737 | .865 | .000 | .787 | .520 | .769 | .650 | .000 | .718 | .818 |

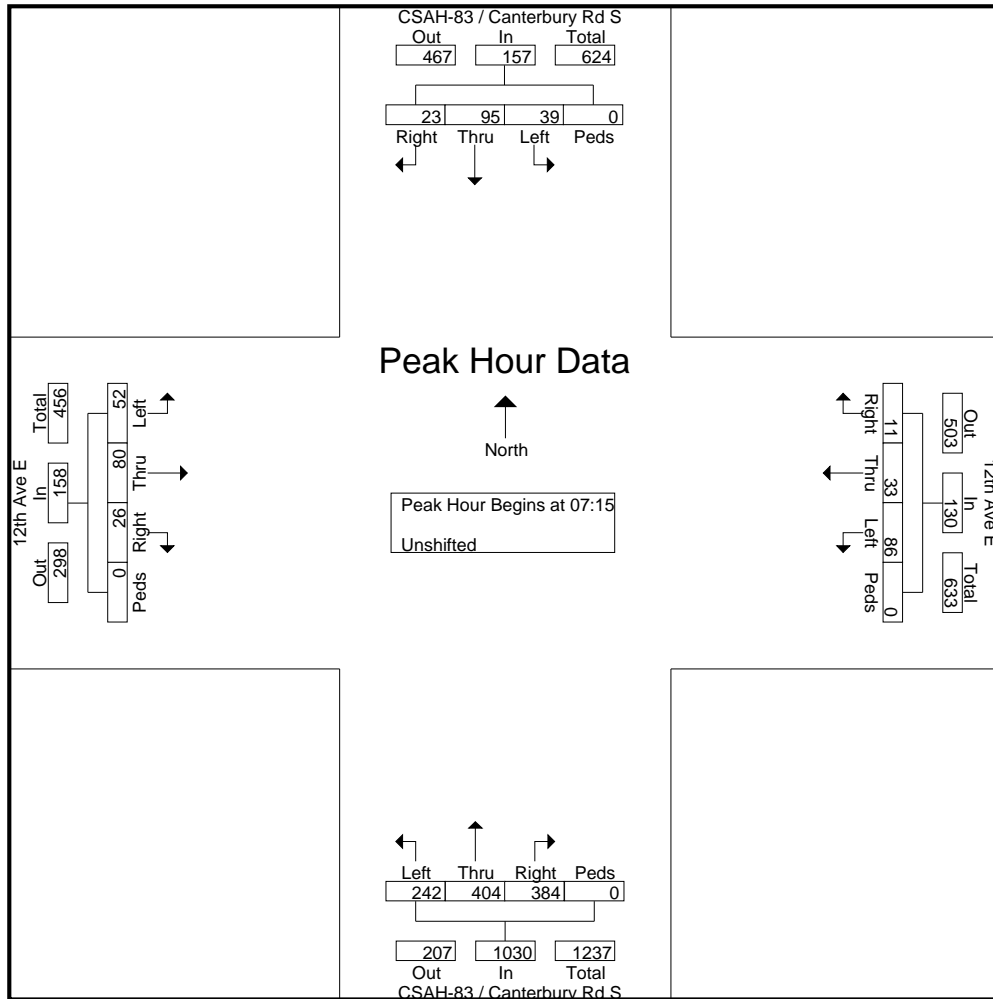

Traffic TURN MOVEMENT COUNT

CSAH-83 / Canterbury Rd S at 12th Ave E
 Ref: Pt.: Shakopee
 Data by: Scott County
 TURN MOVEMENT COUNT

File Name : CSAH-83 Canterbury Rd at 12th Ave 2012
 Site Code : 00000000
 Start Date : 7/25/2012
 Page No : 4

| Start Time | CSAH-83 / Canterbury Rd S Southbound | | | | | 12th Ave E Westbound | | | | | CSAH-83 / Canterbury Rd S Northbound | | | | | 12th Ave E Eastbound | | | | | Int. Total |
|---|--------------------------------------|------|-------|------|------------|----------------------|------|-------|------|------------|--------------------------------------|------|-------|------|------------|----------------------|------|-------|------|------------|------------|
| | Left | Thru | Right | Peds | App. Total | Left | Thru | Right | Peds | App. Total | Left | Thru | Right | Peds | App. Total | Left | Thru | Right | Peds | App. Total | |
| Peak Hour Analysis From 15:00 to 17:45 - Peak 1 of 1 | | | | | | | | | | | | | | | | | | | | | |
| Peak Hour for Entire Intersection Begins at 16:30 | | | | | | | | | | | | | | | | | | | | | |
| 16:30 | 11 | 143 | 14 | 0 | 168 | 125 | 18 | 10 | 0 | 153 | 33 | 44 | 32 | 0 | 109 | 4 | 9 | 52 | 0 | 65 | 495 |
| 16:45 | 7 | 111 | 12 | 0 | 130 | 91 | 10 | 7 | 0 | 108 | 56 | 38 | 22 | 1 | 117 | 2 | 5 | 27 | 0 | 34 | 389 |
| 17:00 | 4 | 106 | 14 | 0 | 124 | 117 | 28 | 5 | 0 | 150 | 46 | 29 | 25 | 0 | 100 | 6 | 9 | 43 | 0 | 58 | 432 |
| 17:15 | 8 | 95 | 15 | 0 | 118 | 97 | 11 | 10 | 0 | 118 | 44 | 38 | 35 | 0 | 117 | 7 | 10 | 35 | 0 | 52 | 405 |
| Total Volume | 30 | 455 | 55 | 0 | 540 | 430 | 67 | 32 | 0 | 529 | 179 | 149 | 114 | 1 | 443 | 19 | 33 | 157 | 0 | 209 | 1721 |
| % App. Total | 5.6 | 84.3 | 10.2 | 0 | | 81.3 | 12.7 | 6 | 0 | | 40.4 | 33.6 | 25.7 | 0.2 | | 9.1 | 15.8 | 75.1 | 0 | | |
| PHF | .682 | .795 | .917 | .000 | .804 | .860 | .598 | .800 | .000 | .864 | .799 | .847 | .814 | .250 | .947 | .679 | .825 | .755 | .000 | .804 | .869 |

