

**Alliant Engineering, Inc**

233 Park Ave Suite 300  
 Minneapolis, MN 55415

--TRAFFIC DATA --

CSAH-83 at TH-169 South Ramp  
 Ref.Pt.: 112.712  
 data by : Alliant Inc.  
 TURN MOVEMENT COUNT

File Name : 343\_CSAH 83 & TH 169 S Ramp  
 Site Code : 343  
 Start Date : 11/8/2017  
 Page No : 1

Groups Printed- Vehicles - Trucks

Start Time	CSAH 83 From North				TH 169 S Ramp From East				CSAH 83 From South				TH 169 S Ramp From West				Int. Total
	Other	Left	Thru	Rght	Other	Left	Thru	Rght	Other	Left	Thru	Rght	Other	Left	Thru	Rght	
06:00 AM	0	19	72	0	0	0	0	0	0	0	53	132	0	40	0	15	331
06:15 AM	0	28	91	0	0	0	0	0	0	0	91	218	0	61	0	6	495
06:30 AM	0	40	101	0	0	0	0	0	0	0	70	257	0	70	0	16	554
06:45 AM	0	26	109	0	0	0	0	0	0	0	178	245	0	88	0	22	668
Total	0	113	373	0	0	0	0	0	0	0	392	852	0	259	0	59	2048
07:00 AM	0	21	77	0	0	0	0	0	0	0	164	269	0	61	1	14	607
07:15 AM	0	19	94	0	0	0	0	0	0	0	181	262	0	85	2	20	663
07:30 AM	0	35	103	0	0	0	0	0	0	0	211	283	0	120	0	32	784
07:45 AM	0	21	123	0	0	0	0	0	0	0	163	155	0	98	0	50	610
Total	0	96	397	0	0	0	0	0	0	0	719	969	0	364	3	116	2664
08:00 AM	0	30	91	0	0	0	0	0	0	0	139	196	0	51	1	28	536
08:15 AM	0	23	115	0	0	0	0	0	0	0	99	175	0	49	0	28	489
08:30 AM	0	34	120	0	0	0	0	0	0	0	76	157	0	45	0	24	456
08:45 AM	0	27	131	0	0	0	0	0	0	0	67	175	0	38	1	18	457
Total	0	114	457	0	0	0	0	0	0	0	381	703	0	183	2	98	1938
09:00 AM	0	20	107	0	0	0	0	0	0	0	72	139	0	25	1	20	384
09:15 AM	0	27	138	0	0	0	0	0	0	0	51	129	0	24	0	22	391
*** BREAK ***																	
Total	0	47	245	0	0	0	0	0	0	0	123	268	0	49	1	42	775
*** BREAK ***																	
10:30 AM	0	44	153	0	0	0	0	0	0	0	57	112	0	20	0	14	400
10:45 AM	0	54	145	0	0	0	0	0	0	0	55	94	0	32	0	19	399
Total	0	98	298	0	0	0	0	0	0	0	112	206	0	52	0	33	799
11:00 AM	0	68	145	0	0	0	0	0	0	0	55	102	0	24	0	17	411
11:15 AM	0	74	162	0	0	0	0	0	0	0	77	105	0	32	0	16	466
11:30 AM	0	90	185	0	0	0	0	0	0	0	70	102	0	31	1	16	495
11:45 AM	0	69	198	0	0	0	0	0	0	0	86	106	0	28	0	32	519
Total	0	301	690	0	0	0	0	0	0	0	288	415	0	115	1	81	1891
12:00 PM	1	78	175	0	0	0	0	0	0	0	80	111	0	31	0	13	489
12:15 PM	0	71	193	0	0	0	0	0	0	0	87	139	0	16	0	17	523
12:30 PM	0	48	181	0	0	0	0	0	0	0	90	115	0	34	1	26	495
12:45 PM	3	44	163	0	0	0	0	0	0	0	99	123	0	33	0	20	485
Total	4	241	712	0	0	0	0	0	0	0	356	488	0	114	1	76	1992
01:00 PM	0	44	183	0	0	0	0	0	0	0	77	108	0	23	1	19	455
01:15 PM	0	67	180	0	0	0	0	0	0	0	85	112	0	32	0	18	494
*** BREAK ***																	
Total	0	111	363	0	0	0	0	0	0	0	162	220	0	55	1	37	949
*** BREAK ***																	
02:30 PM	1	80	211	0	0	0	0	0	0	0	81	135	0	27	0	17	552
02:45 PM	0	64	204	0	0	0	0	0	0	0	73	136	0	32	0	21	530
Total	1	144	415	0	0	0	0	0	0	0	154	271	0	59	0	38	1082
03:00 PM	0	90	242	0	0	0	0	0	0	0	72	127	0	27	0	24	582
03:15 PM	0	75	276	0	0	0	0	0	0	0	73	171	0	23	0	25	643
03:30 PM	0	68	326	0	0	0	0	0	0	0	73	149	0	28	0	33	677
03:45 PM	0	61	288	0	0	0	0	0	0	0	73	155	0	32	0	26	635
Total	0	294	1132	0	0	0	0	0	0	0	291	602	0	110	0	108	2537
04:00 PM	0	76	336	0	0	0	0	0	0	0	87	174	0	23	0	23	719
04:15 PM	0	93	359	0	0	0	0	0	0	0	80	151	0	20	0	25	728
04:30 PM	0	98	323	0	0	0	0	0	0	0	99	180	0	16	0	26	742
04:45 PM	0	86	320	0	0	0	0	0	0	0	97	154	0	27	0	21	705
Total	0	353	1338	0	0	0	0	0	0	0	363	659	0	86	0	95	2894

**Alliant Engineering, Inc**

233 Park Ave Suite 300

Minneapolis, MN 55415

--TRAFFIC DATA --

CSAH-83 at TH-169 South Ramp

Ref.Pt.: 112.712

data by : Alliant Inc.

TURN MOVEMENT COUNT

File Name : 343\_CSAH 83 & TH 169 S Ramp

Site Code : 343

Start Date : 11/8/2017

Page No : 2

Groups Printed- Vehicles - Trucks

Start Time	CSAH 83 From North				TH 169 S Ramp From East				CSAH 83 From South				TH 169 S Ramp From West				Int. Total
	Other	Left	Thru	Rght	Other	Left	Thru	Rght	Other	Left	Thru	Rght	Other	Left	Thru	Rght	
05:00 PM	0	106	374	0	0	0	0	0	0	0	85	182	0	19	0	28	794
05:15 PM	0	122	329	0	0	0	0	0	0	0	80	160	0	25	2	27	745
05:30 PM	0	109	370	0	0	0	0	0	1	0	78	136	0	15	0	24	733
05:45 PM	0	88	257	0	0	0	0	0	0	0	60	127	0	26	1	25	584
Total	0	425	1330	0	0	0	0	0	1	0	303	605	0	85	3	104	2856
Grand Total	5	2337	7750	0	0	0	0	0	1	0	3644	6258	0	1531	12	887	22425
Apprch %	0	23.2	76.8	0	0	0	0	0	0	0	36.8	63.2	0	63	0.5	36.5	
Total %	0	10.4	34.6	0	0	0	0	0	0	0	16.2	27.9	0	6.8	0.1	4	
Vehicles	4	2068	7451	0	0	0	0	0	1	0	3492	6044	0	1380	11	837	21288
% Vehicles	80	88.5	96.1	0	0	0	0	0	100	0	95.8	96.6	0	90.1	91.7	94.4	94.9
Trucks	1	269	299	0	0	0	0	0	0	0	152	214	0	151	1	50	1137
% Trucks	20	11.5	3.9	0	0	0	0	0	0	0	4.2	3.4	0	9.9	8.3	5.6	5.1

**Alliant Engineering, Inc**

233 Park Ave Suite 300  
 Minneapolis, MN 55415

--TRAFFIC DATA --

CSAH-83 at TH-169 South Ramp  
 Ref.Pt.: 112.712  
 data by : Alliant Inc.  
 TURN MOVEMENT COUNT

File Name : 343\_CSAH 83 & TH 169 S Ramp  
 Site Code : 343  
 Start Date : 11/8/2017  
 Page No : 3

Start Time	CSAH 83 From North					TH 169 S Ramp From East					CSAH 83 From South					TH 169 S Ramp From West					Int. Total
	Other	Left	Thru	Right	App. Total	Other	Left	Thru	Right	App. Total	Other	Left	Thru	Right	App. Total	Other	Left	Thru	Right	App. Total	
Peak Hour Analysis From 06:00 AM to 11:45 AM - Peak 1 of 1																					
Peak Hour for Entire Intersection Begins at 06:45 AM																					
06:45 AM	0	26	109	0	135	0	0	0	0	0	0	0	178	245	423	0	88	0	22	110	668
07:00 AM	0	21	77	0	98	0	0	0	0	0	0	0	164	269	433	0	61	1	14	76	607
07:15 AM	0	19	94	0	113	0	0	0	0	0	0	0	181	262	443	0	85	2	20	107	663
07:30 AM	0	35	103	0	138	0	0	0	0	0	0	0	211	283	494	0	120	0	32	152	784
Total Volume	0	101	383	0	484	0	0	0	0	0	0	0	734	1059	1793	0	354	3	88	445	2722
% App. Total	0	20.9	79.1	0		0	0	0	0	0	0	0	40.9	59.1		0	79.6	0.7	19.8		
PHF	.000	.721	.878	.000	.877	.000	.000	.000	.000	.000	.000	.000	.870	.936	.907	.000	.738	.375	.688	.732	.868

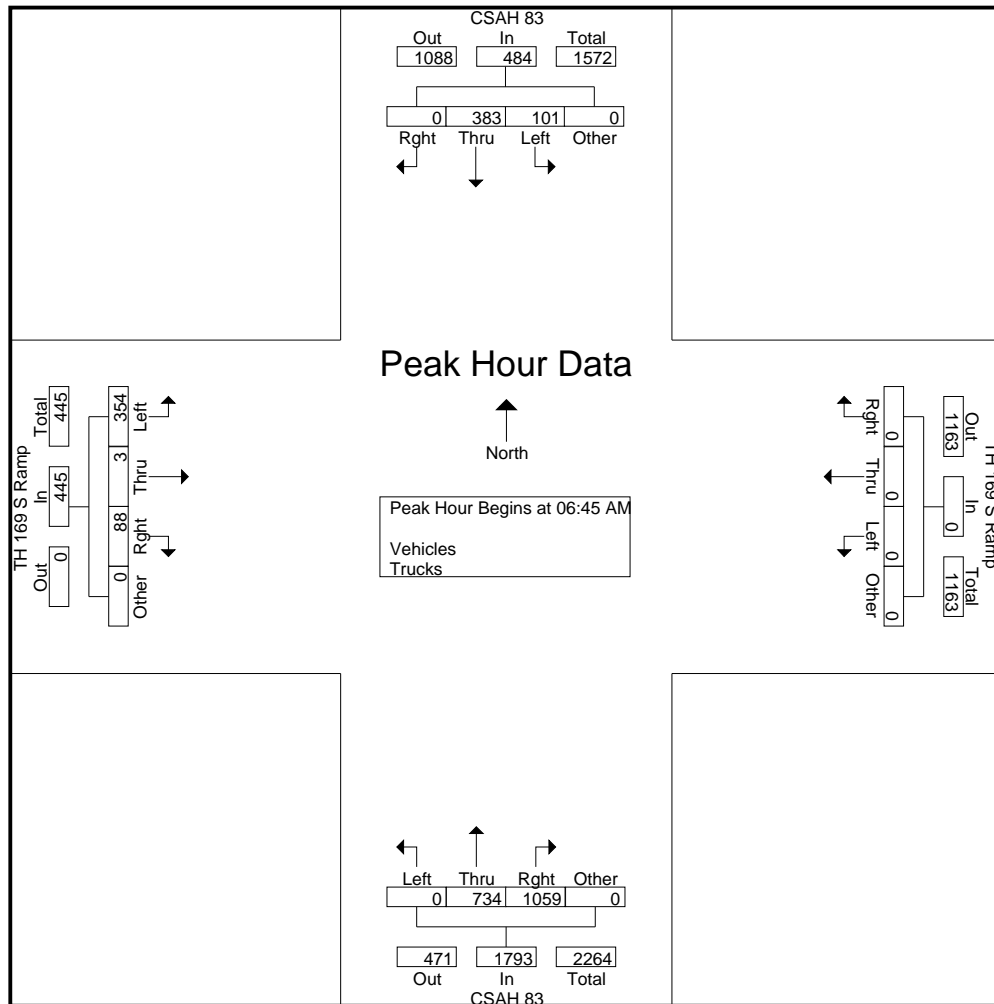

**Alliant Engineering, Inc**

233 Park Ave Suite 300  
 Minneapolis, MN 55415

--TRAFFIC DATA --

CSAH-83 at TH-169 South Ramp  
 Ref.Pt.: 112.712  
 data by : Alliant Inc.  
 TURN MOVEMENT COUNT

File Name : 343\_CSAH 83 & TH 169 S Ramp  
 Site Code : 343  
 Start Date : 11/8/2017  
 Page No : 4

Start Time	CSAH 83 From North					TH 169 S Ramp From East					CSAH 83 From South					TH 169 S Ramp From West					Int. Total
	Other	Left	Thru	Rght	App. Total	Other	Left	Thru	Rght	App. Total	Other	Left	Thru	Rght	App. Total	Other	Left	Thru	Rght	App. Total	
Peak Hour Analysis From 12:00 PM to 05:45 PM - Peak 1 of 1																					
Peak Hour for Entire Intersection Begins at 04:30 PM																					
04:30 PM	0	98	323	0	421	0	0	0	0	0	0	0	99	180	279	0	16	0	26	42	742
04:45 PM	0	86	320	0	406	0	0	0	0	0	0	0	97	154	251	0	27	0	21	48	705
05:00 PM	0	106	374	0	480	0	0	0	0	0	0	0	85	182	267	0	19	0	28	47	794
05:15 PM	0	122	329	0	451	0	0	0	0	0	0	0	80	160	240	0	25	2	27	54	745
Total Volume	0	412	1346	0	1758	0	0	0	0	0	0	0	361	676	1037	0	87	2	102	191	2986
% App. Total	0	23.4	76.6	0		0	0	0	0	0	0	0	34.8	65.2		0	45.5	1	53.4		
PHF	.000	.844	.900	.000	.916	.000	.000	.000	.000	.000	.000	.000	.912	.929	.929	.000	.806	.250	.911	.884	.940

