

SRF Consulting Group, Inc

Minneapolis, MN 55447

TH-169 at Marschall Rd S, south ramps
 Ref.Pt.: 110.732
 data by SRF
 TURN MOVEMENT COUNT

File Name : TH-169 at Marschall Rd S south ramps 2010
 Site Code : 00111602
 Start Date : 11/16/2010
 Page No : 1

Groups Printed- Unshifted

Start Time	Marschall Rd Northbound				Marschall Rd Southbound				EB TH 169 Off Ramp Eastbound				Westbound				Int. Total
	Left	Thru	Right	Peds	Left	Thru	Right	Peds	Left	Thru	Right	Peds	Left	Thru	Right	Peds	
06:30	0	86	233	0	70	70	3	0	11	0	13	0	0	0	0	0	486
06:45	0	96	179	0	81	71	0	0	20	1	31	0	0	0	0	0	479
Total	0	182	412	0	151	141	3	0	31	1	44	0	0	0	0	0	965
07:00	0	102	207	0	87	73	0	0	17	0	13	0	0	0	0	0	499
07:15	0	140	183	0	76	108	0	0	15	6	37	0	0	0	0	0	565
07:30	0	175	181	0	77	140	0	0	26	0	38	0	0	0	0	0	637
07:45	0	140	187	0	31	224	0	0	59	0	59	0	0	0	0	0	700
Total	0	557	758	0	271	545	0	0	117	6	147	0	0	0	0	0	2401
08:00	0	129	161	0	74	177	0	0	21	0	39	0	0	0	0	0	601
08:15	0	129	131	0	66	117	0	0	25	1	31	0	0	0	0	0	500
Total	0	258	292	0	140	294	0	0	46	1	70	0	0	0	0	0	1101
16:00	0	186	54	0	76	329	0	0	37	0	29	0	0	0	0	0	711
16:15	0	151	66	4	53	329	0	0	37	1	33	0	0	0	0	0	674
16:30	0	191	68	0	68	379	0	0	24	0	34	0	0	0	0	0	764
16:45	0	187	75	0	64	334	0	0	39	0	40	0	0	0	0	0	739
Total	0	715	263	4	261	1371	0	0	137	1	136	0	0	0	0	0	2888
17:00	0	194	89	0	58	410	0	0	23	0	39	0	0	0	0	0	813
17:15	0	185	69	0	70	369	0	0	32	0	31	0	0	0	0	0	756
17:30	0	188	64	0	60	367	0	0	39	0	26	0	0	0	0	0	744
17:45	0	177	53	0	48	332	0	0	29	0	33	0	0	0	0	0	672
Total	0	744	275	0	236	1478	0	0	123	0	129	0	0	0	0	0	2985
Grand Total	0	2456	2000	4	1059	3829	3	0	454	9	526	0	0	0	0	0	10340
Apprch %	0	55.1	44.8	0.1	21.7	78.3	0.1	0	45.9	0.9	53.2	0	0	0	0	0	
Total %	0	23.8	19.3	0	10.2	37	0	0	4.4	0.1	5.1	0	0	0	0	0	

SRF Consulting Group, Inc

Minneapolis, MN 55447

TH-169 at Marschall Rd S, south ramps
 Ref.Pt.: 110.732
 data by SRF
 TURN MOVEMENT COUNT

File Name : TH-169 at Marschall Rd S south ramps 2010
 Site Code : 00111602
 Start Date : 11/16/2010
 Page No : 2

Start Time	Marschall Rd Northbound					Marschall Rd Southbound					EB TH 169 Off Ramp Eastbound					Westbound					Int. Total
	Left	Thru	Right	Peds	App. Total	Left	Thru	Right	Peds	App. Total	Left	Thru	Right	Peds	App. Total	Left	Thru	Right	Peds	App. Total	
Peak Hour Analysis From 06:30 to 11:45 - Peak 1 of 1																					
Peak Hour for Entire Intersection Begins at 07:15																					
07:15	0	140	183	0	323	76	108	0	0	184	15	6	37	0	58	0	0	0	0	0	565
07:30	0	175	181	0	356	77	140	0	0	217	26	0	38	0	64	0	0	0	0	0	637
07:45	0	140	187	0	327	31	224	0	0	255	59	0	59	0	118	0	0	0	0	0	700
08:00	0	129	161	0	290	74	177	0	0	251	21	0	39	0	60	0	0	0	0	0	601
Total Volume	0	584	712	0	1296	258	649	0	0	907	121	6	173	0	300	0	0	0	0	0	2503
% App. Total	0	45.1	54.9	0		28.4	71.6	0	0		40.3	2	57.7	0		0	0	0	0		
PHF	.000	.834	.952	.000	.910	.838	.724	.000	.000	.889	.513	.250	.733	.000	.636	.000	.000	.000	.000	.000	.894

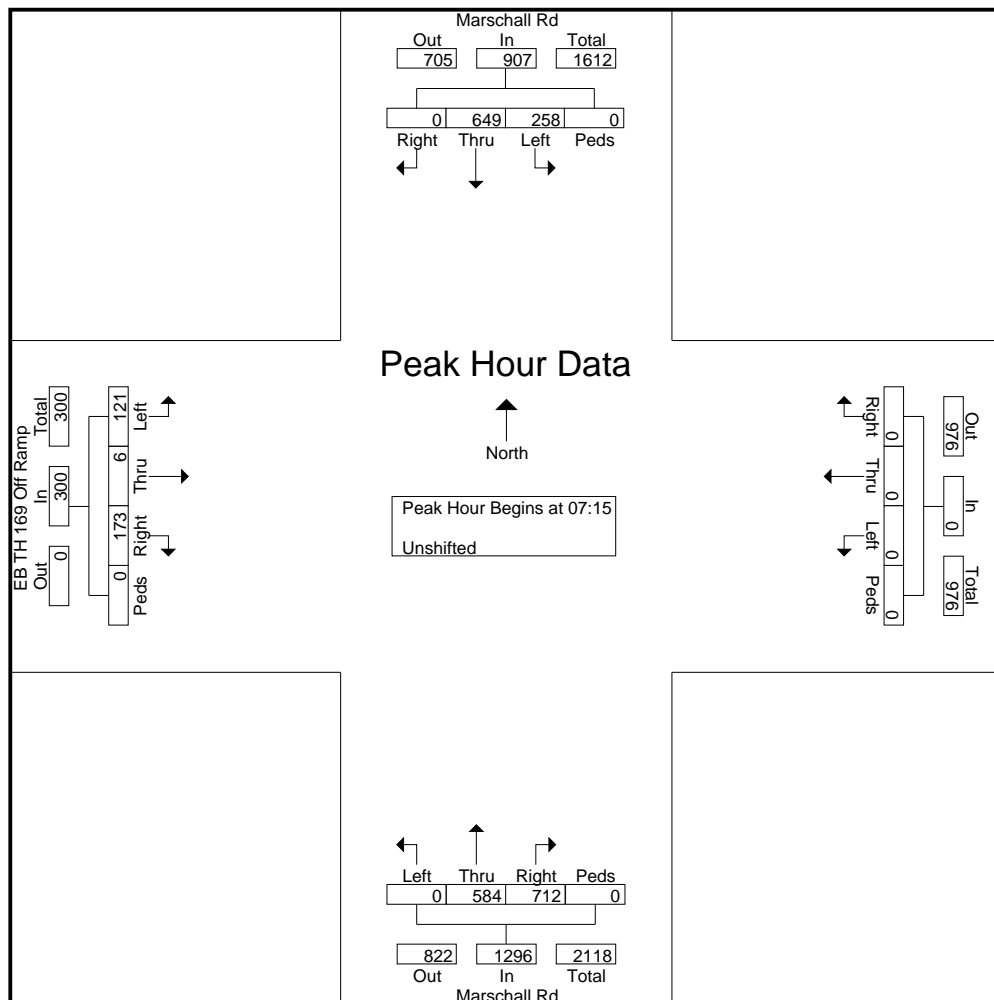

SRF Consulting Group, Inc

Minneapolis, MN 55447

TH-169 at Marschall Rd S, south ramps
 Ref.Pt.: 110.732
 data by SRF
 TURN MOVEMENT COUNT

File Name : TH-169 at Marschall Rd S south ramps 2010
 Site Code : 00111602
 Start Date : 11/16/2010
 Page No : 3

Start Time	Marschall Rd Northbound					Marschall Rd Southbound					EB TH 169 Off Ramp Eastbound					Westbound					Int. Total
	Left	Thru	Right	Peds	App. Total	Left	Thru	Right	Peds	App. Total	Left	Thru	Right	Peds	App. Total	Left	Thru	Right	Peds	App. Total	

Peak Hour Analysis From 16:00 to 17:45 - Peak 1 of 1
 Peak Hour for Entire Intersection Begins at 16:30

16:30	0	191	68	0	259	68	379	0	0	447	24	0	34	0	58	0	0	0	0	0	764
16:45	0	187	75	0	262	64	334	0	0	398	39	0	40	0	79	0	0	0	0	0	739
17:00	0	194	89	0	283	58	410	0	0	468	23	0	39	0	62	0	0	0	0	0	813
17:15	0	185	69	0	254	70	369	0	0	439	32	0	31	0	63	0	0	0	0	0	756
Total Volume	0	757	301	0	1058	260	1492	0	0	1752	118	0	144	0	262	0	0	0	0	0	3072
% App. Total	0	71.6	28.4	0		14.8	85.2	0	0		45	0	55	0		0	0	0	0		
PHF	.000	.976	.846	.000	.935	.929	.910	.000	.000	.936	.756	.000	.900	.000	.829	.000	.000	.000	.000	.000	.945

