

# Alliant Engineering

Minneapolis, MN 55415

--TRAFFIC DATA --

TH-156 at Villaume Ave.  
 Ref.Pt.: 000.250  
 data by Alliant Engineering  
 TURN MOVEMENT COUNT

File Name : 505 - TH 156 and Villuame Ave  
 Site Code : 505  
 Start Date : 4/14/2015  
 Page No : 1

Groups Printed- Cars - Trucks

Start Time	TH-156 Southbound				Villaume Ave Westbound				TH-156 Northbound				Villaume Ave Eastbound				Int. Total
	Left	Thru	Rght	Bikes	Left	Thru	Rght	Bikes	Left	Thru	Rght	Bikes	Left	Thru	Rght	Bikes	
06:00	1	20	1	0	4	2	5	0	7	43	10	0	0	2	2	0	97
06:15	0	32	0	0	6	0	0	0	1	44	8	0	0	3	5	0	99
06:30	4	37	1	0	5	0	3	0	4	51	10	0	2	6	13	0	136
06:45	8	37	2	0	4	1	2	0	7	82	22	0	0	7	5	0	177
Total	13	126	4	0	19	3	10	0	19	220	50	0	2	18	25	0	509
07:00	6	46	0	0	9	3	0	0	12	83	15	0	1	0	13	0	188
07:15	2	52	3	0	8	1	2	0	12	86	12	0	4	2	11	0	195
07:30	3	56	2	0	15	4	4	0	20	99	19	0	2	1	12	0	237
07:45	2	54	2	0	15	8	9	0	11	78	20	0	3	2	16	0	220
Total	13	208	7	0	47	16	15	0	55	346	66	0	10	5	52	0	840
08:00	13	52	3	0	15	8	1	0	10	75	15	0	5	3	13	2	215
08:15	11	52	5	0	17	9	9	0	7	91	15	0	2	4	13	0	235
08:30	10	71	10	0	16	2	1	0	8	80	15	0	3	6	11	1	234
08:45	5	75	2	1	6	0	4	0	10	62	10	0	1	6	9	0	191
Total	39	250	20	1	54	19	15	0	35	308	55	0	11	19	46	3	875
09:00	15	52	5	1	9	3	6	0	7	68	6	0	2	2	7	1	184
09:15	8	46	1	0	13	1	2	0	10	56	11	0	3	4	18	0	173
*** BREAK ***																	
Total	23	98	6	1	22	4	8	0	17	124	17	0	5	6	25	1	357
*** BREAK ***																	
10:30	2	61	1	0	12	2	6	0	10	45	9	1	2	4	9	0	164
10:45	0	55	2	0	6	4	0	0	11	53	14	0	0	1	3	0	149
Total	2	116	3	0	18	6	6	0	21	98	23	1	2	5	12	0	313
11:00	8	62	2	0	14	0	4	0	11	55	17	0	1	2	8	0	184
11:15	7	72	1	0	15	2	5	0	18	52	14	0	1	0	7	0	194
11:30	3	71	2	0	10	1	9	0	12	64	16	0	1	1	8	0	198
11:45	5	73	0	0	22	1	5	0	11	61	12	0	0	3	5	0	198
Total	23	278	5	0	61	4	23	0	52	232	59	0	3	6	28	0	774
12:00	5	70	2	0	18	2	11	0	9	60	13	0	3	2	8	0	203
12:15	7	76	3	0	26	6	5	0	11	62	18	0	1	0	8	0	223
12:30	6	95	5	0	25	4	2	0	10	57	12	0	3	4	6	0	229
12:45	3	66	2	0	13	7	4	0	7	78	10	0	2	4	4	1	201
Total	21	307	12	0	82	19	22	0	37	257	53	0	9	10	26	1	856
13:00	9	76	1	0	11	5	4	1	9	61	14	0	0	3	2	0	196
13:15	5	60	1	0	21	9	5	1	10	57	19	0	1	5	13	0	207
*** BREAK ***																	
Total	14	136	2	0	32	14	9	2	19	118	33	0	1	8	15	0	403
*** BREAK ***																	
14:30	4	82	0	0	14	7	5	0	16	67	17	0	2	2	17	0	233
14:45	5	144	3	0	15	9	0	1	10	76	16	1	1	2	11	0	294
Total	9	226	3	0	29	16	5	1	26	143	33	1	3	4	28	0	527
15:00	6	112	0	0	19	4	5	1	15	79	10	0	0	1	10	0	262
15:15	3	114	1	0	14	4	7	0	8	67	8	0	3	5	12	0	246
15:30	5	136	3	0	12	5	9	1	10	64	9	0	2	3	10	0	269
15:45	5	113	0	0	19	12	8	1	13	77	18	0	1	4	9	1	281
Total	19	475	4	0	64	25	29	3	46	287	45	0	6	13	41	1	1058
16:00	2	106	1	0	21	5	0	2	18	82	7	0	1	4	10	0	259
16:15	6	110	2	0	13	1	4	0	14	69	9	0	2	3	12	0	245
16:30	1	130	6	0	16	12	3	0	15	63	12	0	0	2	5	0	265

# Alliant Engineering

Minneapolis, MN 55415

--TRAFFIC DATA --

TH-156 at Villaume Ave.  
 Ref.Pt.: 000.250  
 data by Alliant Engineering  
 TURN MOVEMENT COUNT

File Name : 505 - TH 156 and Villuame Ave  
 Site Code : 505  
 Start Date : 4/14/2015  
 Page No : 2

Groups Printed- Cars - Trucks

Start Time	TH-156 Southbound				Villaume Ave Westbound				TH-156 Northbound				Villaume Ave Eastbound				Int. Total
	Left	Thru	Rght	Bikes	Left	Thru	Rght	Bikes	Left	Thru	Rght	Bikes	Left	Thru	Rght	Bikes	
16:45	6	115	2	0	23	2	3	0	9	52	7	0	0	3	7	0	229
Total	15	461	11	0	73	20	10	2	56	266	35	0	3	12	34	0	998
17:00	9	111	2	0	25	5	10	0	19	64	10	0	2	2	13	0	272
17:15	5	105	2	0	17	9	5	0	22	65	9	0	1	0	12	0	252
17:30	8	114	2	0	10	6	4	0	15	58	9	0	3	1	16	0	246
17:45	7	76	2	0	10	10	3	0	19	58	8	0	1	0	18	2	214
Total	29	406	8	0	62	30	22	0	75	245	36	0	7	3	59	2	984
*** BREAK ***																	
Grand Total	220	3087	85	2	563	176	174	8	458	2644	505	2	62	109	391	8	8494
Apprch %	6.5	91	2.5	0.1	61.1	19.1	18.9	0.9	12.7	73.3	14	0.1	10.9	19.1	68.6	1.4	
Total %	2.6	36.3	1	0	6.6	2.1	2	0.1	5.4	31.1	5.9	0	0.7	1.3	4.6	0.1	
Cars	202	2805	82	1	481	171	152	5	437	2410	429	2	58	108	384	6	7733
% Cars	91.8	90.9	96.5	50	85.4	97.2	87.4	62.5	95.4	91.1	85	100	93.5	99.1	98.2	75	91
Trucks	18	282	3	1	82	5	22	3	21	234	76	0	4	1	7	2	761
% Trucks	8.2	9.1	3.5	50	14.6	2.8	12.6	37.5	4.6	8.9	15	0	6.5	0.9	1.8	25	9

# Alliant Engineering

Minneapolis, MN 55415

--TRAFFIC DATA --

TH-156 at Villaume Ave.  
 Ref.Pt.: 000.250  
 data by Alliant Engineering  
 TURN MOVEMENT COUNT

File Name : 505 - TH 156 and Villuame Ave  
 Site Code : 505  
 Start Date : 4/14/2015  
 Page No : 3

Start Time	TH-156 Southbound					Villaume Ave Westbound					TH-156 Northbound					Villaume Ave Eastbound					Int. Total
	Left	Thru	Rght	Bikes	App. Total	Left	Thru	Rght	Bikes	App. Total	Left	Thru	Rght	Bikes	App. Total	Left	Thru	Rght	Bikes	App. Total	
Peak Hour Analysis From 06:00 to 11:45 - Peak 1 of 1																					
Peak Hour for Entire Intersection Begins at 07:30																					
07:30	3	56	2	0	61	15	4	4	0	23	20	99	19	0	138	2	1	12	0	15	237
07:45	2	54	2	0	58	15	8	9	0	32	11	78	20	0	109	3	2	16	0	21	220
08:00	13	52	3	0	68	15	8	1	0	24	10	75	15	0	100	5	3	13	2	23	215
08:15	11	52	5	0	68	17	9	9	0	35	7	91	15	0	113	2	4	13	0	19	235
Total Volume	29	214	12	0	255	62	29	23	0	114	48	343	69	0	460	12	10	54	2	78	907
% App. Total	11.4	83.9	4.7	0		54.4	25.4	20.2	0		10.4	74.6	15	0		15.4	12.8	69.2	2.6		
PHF	.558	.955	.600	.000	.938	.912	.806	.639	.000	.814	.600	.866	.863	.000	.833	.600	.625	.844	.250	.848	.957

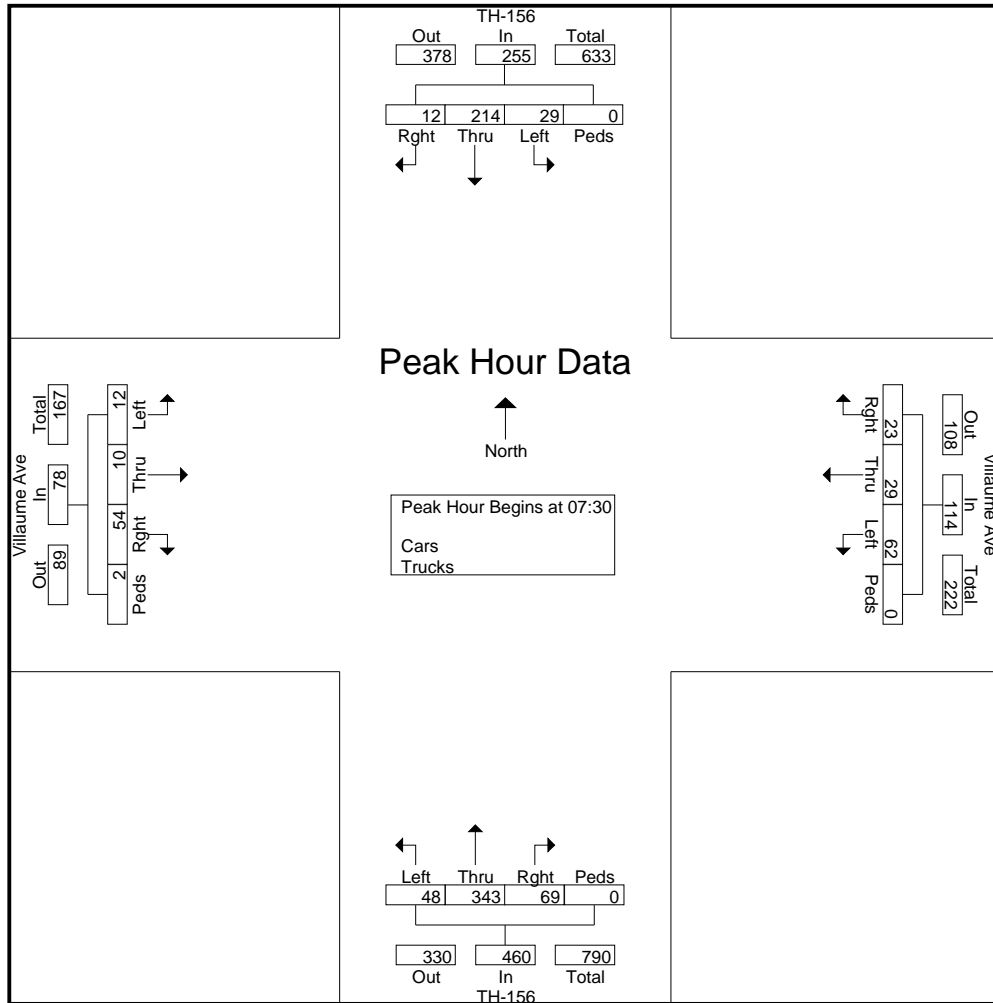

# Alliant Engineering

Minneapolis, MN 55415

--TRAFFIC DATA --

TH-156 at Villaume Ave.  
 Ref.Pt.: 000.250  
 data by Alliant Engineering  
 TURN MOVEMENT COUNT

File Name : 505 - TH 156 and Villuame Ave  
 Site Code : 505  
 Start Date : 4/14/2015  
 Page No : 4

Start Time	TH-156 Southbound					Villaume Ave Westbound					TH-156 Northbound					Villaume Ave Eastbound					Int. Total
	Left	Thru	Rght	Bikes	App. Total	Left	Thru	Rght	Bikes	App. Total	Left	Thru	Rght	Bikes	App. Total	Left	Thru	Rght	Bikes	App. Total	
Peak Hour Analysis From 12:00 to 18:00 - Peak 1 of 1																					
Peak Hour for Entire Intersection Begins at 14:45																					
14:45	5	144	3	0	152	15	9	0	1	25	10	76	16	1	103	1	2	11	0	14	294
15:00	6	112	0	0	118	19	4	5	1	29	15	79	10	0	104	0	1	10	0	11	262
15:15	3	114	1	0	118	14	4	7	0	25	8	67	8	0	83	3	5	12	0	20	246
15:30	5	136	3	0	144	12	5	9	1	27	10	64	9	0	83	2	3	10	0	15	269
Total Volume	19	506	7	0	532	60	22	21	3	106	43	286	43	1	373	6	11	43	0	60	1071
% App. Total	3.6	95.1	1.3	0		56.6	20.8	19.8	2.8		11.5	76.7	11.5	0.3		10	18.3	71.7	0		
PHF	.792	.878	.583	.000	.875	.789	.611	.583	.750	.914	.717	.905	.672	.250	.897	.500	.550	.896	.000	.750	.911

