

Associated Consulting Services (ACS)  
 Roseville, MN 55113  
 -- TRAFFIC DATA --

TH-149 at Goodrich Ave\_2021  
 Data Prepared By: ACS  
 TURNING MOVEMENT COUNT

File Name : TH-149 at Goodrich Ave\_2021  
 Site Code :  
 Start Date : 8/10/2021  
 Page No : 1

Groups Printed- Cars - Trucks

Start Time	TH-149 Southbound				Goodrich Ave Westbound				TH-149 Northbound				Goodrich Ave Eastbound				Int. Total
	Left	Thru	Right	Peds	Left	Thru	Right	Peds	Left	Thru	Right	Peds	Left	Thru	Right	Peds	
06:00	0	7	0	0	0	0	0	2	0	39	0	0	0	0	1	0	49
06:15	0	9	0	0	0	0	0	0	0	39	0	0	1	0	2	2	53
06:30	0	9	0	0	0	0	0	0	0	73	0	0	0	1	0	2	85
06:45	0	17	0	0	0	0	0	0	1	71	0	0	0	0	1	2	92
Total	0	42	0	0	0	0	0	2	1	222	0	0	1	1	4	6	279
07:00	0	16	0	0	0	0	0	0	0	69	0	0	0	0	2	2	89
07:15	0	23	0	1	2	0	1	2	0	94	0	0	1	0	1	0	125
07:30	0	32	0	0	0	1	2	0	1	99	0	2	1	0	0	1	139
07:45	1	37	2	0	0	0	1	0	3	92	0	0	0	0	2	1	139
Total	1	108	2	1	2	1	4	2	4	354	0	2	2	0	5	4	492
08:00	0	36	0	1	4	0	1	0	2	84	0	0	0	0	5	1	134
08:15	1	39	0	0	0	0	0	4	1	90	2	4	0	0	2	2	145
08:30	0	41	1	0	0	0	1	1	1	85	0	1	0	1	1	1	134
08:45	0	26	3	3	0	0	0	4	2	75	4	0	1	0	5	4	127
Total	1	142	4	4	4	0	2	9	6	334	6	5	1	1	13	8	540
09:00	1	47	1	1	0	0	0	1	0	69	0	0	2	0	3	2	127
09:15	0	50	0	0	1	0	0	3	1	77	0	2	0	0	2	1	137
09:30	0	46	1	0	1	0	0	3	0	72	0	0	1	0	2	1	127
09:45	0	41	1	0	1	0	1	3	1	65	1	0	2	1	3	1	121
Total	1	184	3	1	3	0	1	10	2	283	1	2	5	1	10	5	512
10:00	1	42	0	0	0	0	1	3	2	59	1	4	1	0	0	0	114
10:15	1	61	0	0	1	0	2	2	4	66	0	0	0	0	2	0	139
10:30	0	53	0	0	0	0	1	0	1	69	0	1	0	0	1	1	127
10:45	1	49	1	1	0	1	1	1	0	51	1	0	1	0	3	2	113
Total	3	205	1	1	1	1	5	6	7	245	2	5	2	0	6	3	493
11:00	1	72	0	0	1	0	0	0	2	59	0	0	0	1	2	0	138
11:15	0	68	1	0	2	0	2	0	4	60	2	1	1	0	2	1	144
11:30	1	70	2	0	0	2	1	1	1	71	2	1	0	0	2	0	154
11:45	0	66	0	0	0	0	1	2	1	67	1	2	1	0	3	0	144
Total	2	276	3	0	3	2	4	3	8	257	5	4	2	1	9	1	580
12:00	1	73	2	2	3	1	1	3	1	56	1	4	0	1	2	3	154
12:15	0	41	4	2	3	0	0	3	0	62	0	1	1	1	1	4	123
12:30	1	62	2	2	2	0	1	4	1	63	1	0	1	0	3	4	147
12:45	2	58	1	1	1	0	0	7	2	70	0	2	1	1	7	0	153
Total	4	234	9	7	9	1	2	17	4	251	2	7	3	3	13	11	577
13:00	3	59	2	3	1	2	0	6	0	67	2	0	2	0	5	0	152
13:15	1	69	1	0	1	1	0	0	1	66	1	0	1	0	1	2	145
13:30	0	67	0	2	2	0	0	1	2	57	1	1	0	1	3	0	137
13:45	1	64	3	2	1	0	1	0	0	71	0	0	0	0	4	3	150
Total	5	259	6	7	5	3	1	7	3	261	4	1	3	1	13	5	584
14:00	1	75	0	0	1	0	1	2	0	56	1	4	0	0	2	0	143
14:15	1	63	2	0	0	1	0	2	5	68	1	0	0	0	2	2	147
14:30	2	69	0	0	1	0	0	2	1	85	0	0	1	0	2	0	163
14:45	0	73	2	0	0	0	0	1	1	70	0	0	0	1	8	1	157
Total	4	280	4	0	2	1	1	7	7	279	2	4	1	1	14	3	610

Associated Consulting Services (ACS)  
 Roseville, MN 55113  
 -- TRAFFIC DATA --

TH-149 at Goodrich Ave\_2021  
 Data Prepared By: ACS  
 TURNING MOVEMENT COUNT

File Name : TH-149 at Goodrich Ave\_2021  
 Site Code :  
 Start Date : 8/10/2021  
 Page No : 2

Groups Printed- Cars - Trucks

Start Time	TH-149 Southbound				Goodrich Ave Westbound				TH-149 Northbound				Goodrich Ave Eastbound				Int. Total
	Left	Thru	Right	Peds	Left	Thru	Right	Peds	Left	Thru	Right	Peds	Left	Thru	Right	Peds	
15:00	0	79	2	0	4	0	1	2	4	61	0	1	0	0	1	1	156
15:15	0	83	3	0	1	0	0	3	1	82	0	0	1	0	0	2	176
15:30	0	105	6	0	3	0	1	0	2	62	2	1	1	0	3	2	188
15:45	1	120	1	1	0	2	1	1	2	88	0	0	1	1	5	5	229
Total	1	387	12	1	8	2	3	6	9	293	2	2	3	1	9	10	749
16:00	0	114	0	1	3	1	1	4	2	57	0	0	0	0	3	2	188
16:15	4	120	3	2	1	0	3	1	3	77	0	0	0	1	5	5	225
16:30	1	136	5	0	3	1	2	0	2	64	2	1	3	0	3	2	225
16:45	3	127	5	2	1	1	0	3	2	76	0	0	1	1	2	7	231
Total	8	497	13	5	8	3	6	8	9	274	2	1	4	2	13	16	869
17:00	3	111	7	2	1	3	3	3	1	91	1	0	0	0	3	9	238
17:15	1	120	4	3	0	2	0	0	1	92	0	0	0	1	4	1	229
17:30	3	112	5	3	4	2	0	1	1	90	1	0	1	2	3	2	230
17:45	8	89	4	0	2	1	1	0	3	81	2	0	2	0	6	7	206
Total	15	432	20	8	7	8	4	4	6	354	4	0	3	3	16	19	903
Grand Total	45	3046	77	35	52	22	33	81	66	3407	30	33	30	15	125	91	7188
Apprch %	1.4	95.1	2.4	1.1	27.7	11.7	17.6	43.1	1.9	96.4	0.8	0.9	11.5	5.7	47.9	34.9	
Total %	0.6	42.4	1.1	0.5	0.7	0.3	0.5	1.1	0.9	47.4	0.4	0.5	0.4	0.2	1.7	1.3	
Cars	45	2975	73	35	47	22	31	81	63	3330	28	33	29	14	119	91	7016
% Cars	100	97.7	94.8	100	90.4	100	93.9	100	95.5	97.7	93.3	100	96.7	93.3	95.2	100	97.6
Trucks	0	71	4	0	5	0	2	0	3	77	2	0	1	1	6	0	172
% Trucks	0	2.3	5.2	0	9.6	0	6.1	0	4.5	2.3	6.7	0	3.3	6.7	4.8	0	2.4

TH-149 at Goodrich Ave\_2021  
 Data Prepared By: ACS  
 TURNING MOVEMENT COUNT

File Name : TH-149 at Goodrich Ave\_2021  
 Site Code :  
 Start Date : 8/10/2021  
 Page No : 3

Start Time	TH-149 Southbound					Goodrich Ave Westbound					TH-149 Northbound					Goodrich Ave Eastbound					Int. Total
	Left	Thru	Right	Peds	App. Total	Left	Thru	Right	Peds	App. Total	Left	Thru	Right	Peds	App. Total	Left	Thru	Right	Peds	App. Total	
Peak Hour Analysis From 06:00 to 11:45 - Peak 1 of 1																					
Peak Hour for Entire Intersection Begins at 11:00																					
11:00	1	72	0	0	73	1	0	0	0	1	2	59	0	0	61	0	1	2	0	3	138
11:15	0	68	1	0	69	2	0	2	0	4	4	60	2	1	67	1	0	2	1	4	144
11:30	1	70	2	0	73	0	2	1	1	4	1	71	2	1	75	0	0	2	0	2	154
11:45	0	66	0	0	66	0	0	1	2	3	1	67	1	2	71	1	0	3	0	4	144
Total Volume	2	276	3	0	281	3	2	4	3	12	8	257	5	4	274	2	1	9	1	13	580
% App. Total	0.7	98.2	1.1	0		25	16.7	33.3	25		2.9	93.8	1.8	1.5		15.4	7.7	69.2	7.7		
PHF	.500	.958	.375	.000	.962	.375	.250	.500	.375	.750	.500	.905	.625	.500	.913	.500	.250	.750	.250	.813	.942

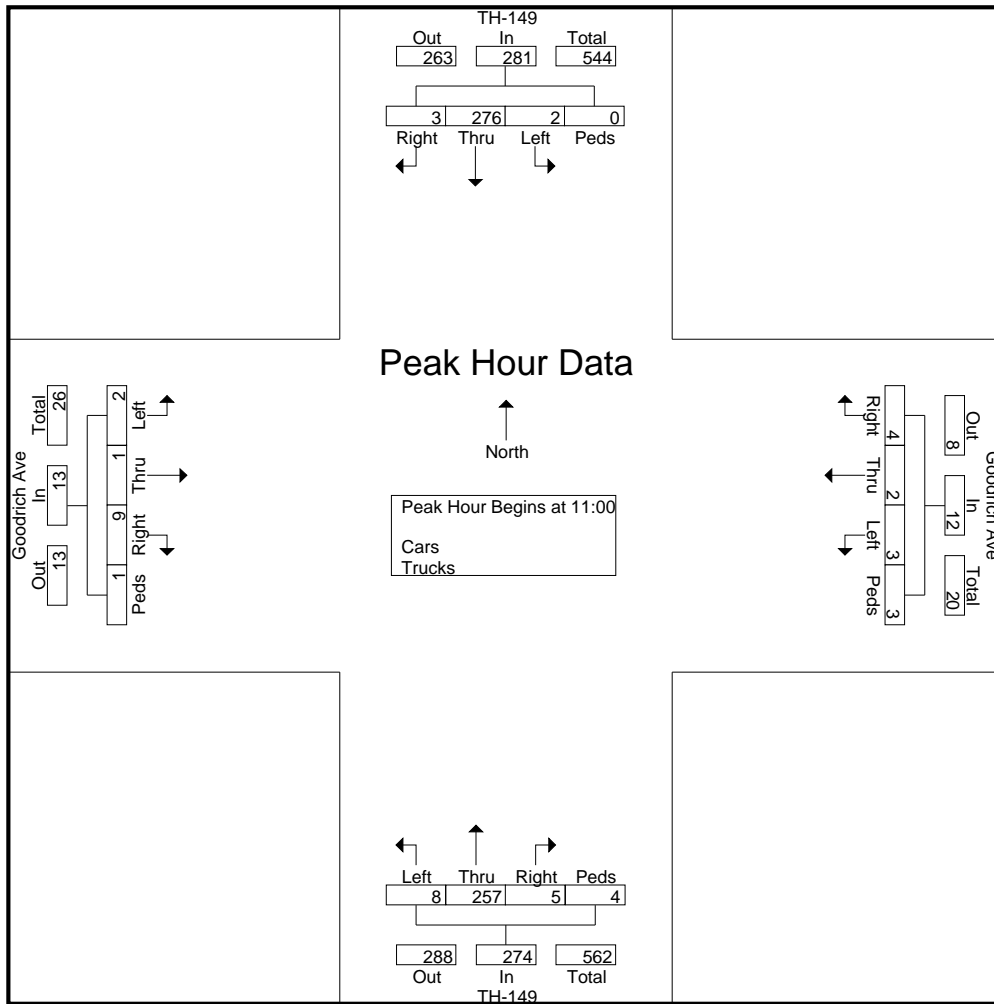

TH-149 at Goodrich Ave\_2021  
 Data Prepared By: ACS  
 TURNING MOVEMENT COUNT

File Name : TH-149 at Goodrich Ave\_2021  
 Site Code :  
 Start Date : 8/10/2021  
 Page No : 4

Start Time	TH-149 Southbound					Goodrich Ave Westbound					TH-149 Northbound					Goodrich Ave Eastbound					Int. Total
	Left	Thru	Right	Peds	App. Total	Left	Thru	Right	Peds	App. Total	Left	Thru	Right	Peds	App. Total	Left	Thru	Right	Peds	App. Total	
Peak Hour Analysis From 12:00 to 17:45 - Peak 1 of 1																					
Peak Hour for Entire Intersection Begins at 16:45																					
16:45	3	127	5	2	137	1	1	0	3	5	2	76	0	0	78	1	1	2	7	11	231
17:00	3	111	7	2	123	1	3	3	3	10	1	91	1	0	93	0	0	3	9	12	238
17:15	1	120	4	3	128	0	2	0	0	2	1	92	0	0	93	0	1	4	1	6	229
17:30	3	112	5	3	123	4	2	0	1	7	1	90	1	0	92	1	2	3	2	8	230
Total Volume	10	470	21	10	511	6	8	3	7	24	5	349	2	0	356	2	4	12	19	37	928
% App. Total	2	92	4.1	2		25	33.3	12.5	29.2		1.4	98	0.6	0		5.4	10.8	32.4	51.4		
PHF	.833	.925	.750	.833	.932	.375	.667	.250	.583	.600	.625	.948	.500	.000	.957	.500	.500	.750	.528	.771	.975

