

# Alliant Engineering Inc Minneapolis, MN 55415

TH-149 at Wescott Rd / Baffin Trail  
 Ref.Pt.: 000.834  
 Alliant Engineering Inc  
 TURN MOVEMENT COUNT

File Name : 19\_TH 149 at Wescott Rd\_030410  
 Site Code : 00000019  
 Start Date : 3/4/2010  
 Page No : 1

**Groups Printed- Unshifted**

Start Time	Dodd Rd/Jefferson Trail W (TH 149) Southbound				Baffin Trail Westbound				Jefferson Trail W (TH 149) Northbound				Wescott Rd Eastbound				Int. Total
	Left	Thru	Right	Peds	Left	Thru	Right	Peds	Left	Thru	Right	Peds	Left	Thru	Right	Peds	
06:00	0	5	7	0	3	24	5	0	20	59	0	0	9	3	4	0	139
06:15	2	5	7	0	2	23	2	0	23	88	2	0	19	6	0	0	179
06:30	0	16	9	0	2	10	3	0	16	113	1	0	21	6	4	0	201
06:45	0	18	11	0	4	11	0	0	27	167	3	0	35	11	7	0	294
Total	2	44	34	0	11	68	10	0	86	427	6	0	84	26	15	0	813
07:00	1	12	2	0	2	13	3	0	25	172	3	0	31	12	2	1	279
07:15	3	22	3	0	6	8	8	1	18	205	2	0	62	21	3	1	363
07:30	3	17	8	0	1	6	5	0	19	215	3	0	48	23	7	0	355
07:45	3	19	7	0	1	9	5	0	35	220	8	0	66	23	4	0	400
Total	10	70	20	0	10	36	21	1	97	812	16	0	207	79	16	2	1397
08:00	2	27	10	0	4	5	4	0	27	174	4	0	51	19	7	0	334
08:15	0	22	12	0	1	4	1	0	16	127	1	0	34	14	3	0	235
08:30	1	28	14	0	3	10	0	0	16	89	5	0	25	8	9	0	208
08:45	1	27	11	0	1	5	2	0	8	84	4	0	18	6	6	0	173
Total	4	104	47	0	9	24	7	0	67	474	14	0	128	47	25	0	950
09:00	1	27	10	0	7	9	0	0	14	72	1	0	26	10	3	0	180
09:15	6	39	9	0	19	14	5	1	9	40	5	0	9	16	9	1	182
*** BREAK ***																	
Total	7	66	19	0	26	23	5	1	23	112	6	0	35	26	12	1	362
*** BREAK ***																	
10:30	1	25	5	0	6	13	1	0	3	24	2	0	8	3	5	0	96
10:45	0	19	8	0	2	7	0	0	5	26	2	0	12	4	6	0	91
Total	1	44	13	0	8	20	1	0	8	50	4	0	20	7	11	0	187
11:00	0	25	8	0	2	12	0	0	6	29	2	0	4	4	2	1	95
11:15	0	24	8	0	3	6	1	0	2	31	4	0	9	3	1	0	92
11:30	0	23	7	0	3	7	0	0	1	49	4	0	9	6	11	1	121
11:45	0	26	4	0	4	9	0	0	8	35	1	0	9	4	5	0	105
Total	0	98	27	0	12	34	1	0	17	144	11	0	31	17	19	2	413
12:00	0	28	8	0	0	6	0	0	5	50	0	0	11	3	5	0	116
12:15	0	31	13	0	3	4	0	0	7	44	3	0	7	4	1	0	117
12:30	1	20	3	0	2	3	2	0	9	34	3	0	8	7	3	0	95
12:45	6	25	20	0	3	4	0	0	8	42	2	0	15	11	9	0	145
Total	7	104	44	0	8	17	2	0	29	170	8	0	41	25	18	0	473
13:00	3	22	7	0	4	3	0	0	2	27	5	0	12	3	4	0	92
13:15	5	32	6	0	4	5	1	0	5	37	7	0	6	8	3	0	119
*** BREAK ***																	
Total	8	54	13	0	8	8	1	0	7	64	12	0	18	11	7	0	211
*** BREAK ***																	
14:30	2	28	11	0	2	11	2	0	1	33	4	0	14	33	24	0	165
14:45	2	70	13	0	2	7	3	1	5	38	5	0	13	12	9	0	180
Total	4	98	24	0	4	18	5	1	6	71	9	0	27	45	33	0	345
15:00	2	82	15	0	7	5	1	0	3	22	5	0	10	24	14	1	191
15:15	1	50	12	0	11	6	1	0	6	35	4	0	8	9	13	0	156
15:30	1	95	19	0	2	18	0	0	11	31	5	0	12	7	11	0	212

# Alliant Engineering Inc Minneapolis, MN 55415

TH-149 at Wescott Rd / Baffin Trail  
 Ref.Pt.: 000.834  
 Alliant Engineering Inc  
 TURN MOVEMENT COUNT

File Name : 19\_TH 149 at Wescott Rd\_030410  
 Site Code : 00000019  
 Start Date : 3/4/2010  
 Page No : 2

**Groups Printed- Unshifted**

Start Time	Dodd Rd/Jefferson Trail W (TH 149) Southbound				Baffin Trail Westbound				Jefferson Trail W (TH 149) Northbound				Wescott Rd Eastbound				Int. Total
	Left	Thru	Right	Peds	Left	Thru	Right	Peds	Left	Thru	Right	Peds	Left	Thru	Right	Peds	
15:45	2	67	15	0	4	3	0	1	2	40	5	0	16	23	21	0	199
Total	6	294	61	0	24	32	2	1	22	128	19	0	46	63	59	1	758
16:00	1	111	27	0	5	9	0	0	7	42	2	0	15	12	20	1	252
16:15	2	127	24	0	6	13	1	0	9	34	5	0	15	27	24	0	287
16:30	0	96	26	0	6	11	2	0	12	34	5	0	15	20	3	0	230
16:45	5	141	43	0	10	21	1	0	10	29	8	0	12	19	2	1	302
Total	8	475	120	0	27	54	4	0	38	139	20	0	57	78	49	2	1071
17:00	0	92	41	0	16	24	1	0	15	44	7	0	8	25	6	0	279
17:15	3	116	59	2	11	29	2	0	1	41	9	0	9	26	11	0	319
17:30	1	178	60	0	7	17	1	0	9	43	3	0	28	22	9	0	378
17:45	1	103	31	0	5	12	0	0	8	56	17	0	16	26	14	0	289
Total	5	489	191	2	39	82	4	0	33	184	36	0	61	99	40	0	1265
Grand Total	62	1940	613	2	186	416	63	4	433	2775	161	0	755	523	304	8	8245
Apprch %	2.4	74.1	23.4	0.1	27.8	62.2	9.4	0.6	12.9	82.4	4.8	0	47.5	32.9	19.1	0.5	
Total %	0.8	23.5	7.4	0	2.3	5	0.8	0	5.3	33.7	2	0	9.2	6.3	3.7	0.1	

# Alliant Engineering Inc Minneapolis, MN 55415

TH-149 at Wescott Rd / Baffin Trail  
 Ref.Pt.: 000.834  
 Alliant Engineering Inc  
 TURN MOVEMENT COUNT

File Name : 19\_TH 149 at Wescott Rd\_030410  
 Site Code : 00000019  
 Start Date : 3/4/2010  
 Page No : 3

Start Time	Dodd Rd/Jefferson Trail W (TH 149) Southbound					Baffin Trail Westbound					Jefferson Trail W (TH 149) Northbound					Wescott Rd Eastbound					Int. Total
	Left	Thru	Right	Peds	App. Total	Left	Thru	Right	Peds	App. Total	Left	Thru	Right	Peds	App. Total	Left	Thru	Right	Peds	App. Total	
Peak Hour Analysis From 06:00 to 09:15 - Peak 1 of 1																					
Peak Hour for Entire Intersection Begins at 07:15																					
07:15	3	22	3	0	28	6	8	8	1	23	18	205	2	0	225	62	21	3	1	87	363
07:30	3	17	8	0	28	1	6	5	0	12	19	215	3	0	237	48	23	7	0	78	355
07:45	3	19	7	0	29	1	9	5	0	15	35	220	8	0	263	66	23	4	0	93	400
08:00	2	27	10	0	39	4	5	4	0	13	27	174	4	0	205	51	19	7	0	77	334
Total Volume	11	85	28	0	124	12	28	22	1	63	99	814	17	0	930	227	86	21	1	335	1452
% App. Total	8.9	68.5	22.6	0		19	44.4	34.9	1.6		10.6	87.5	1.8	0		67.8	25.7	6.3	0.3		
PHF	.917	.787	.700	.000	.795	.500	.778	.688	.250	.685	.707	.925	.531	.000	.884	.860	.935	.750	.250	.901	.908

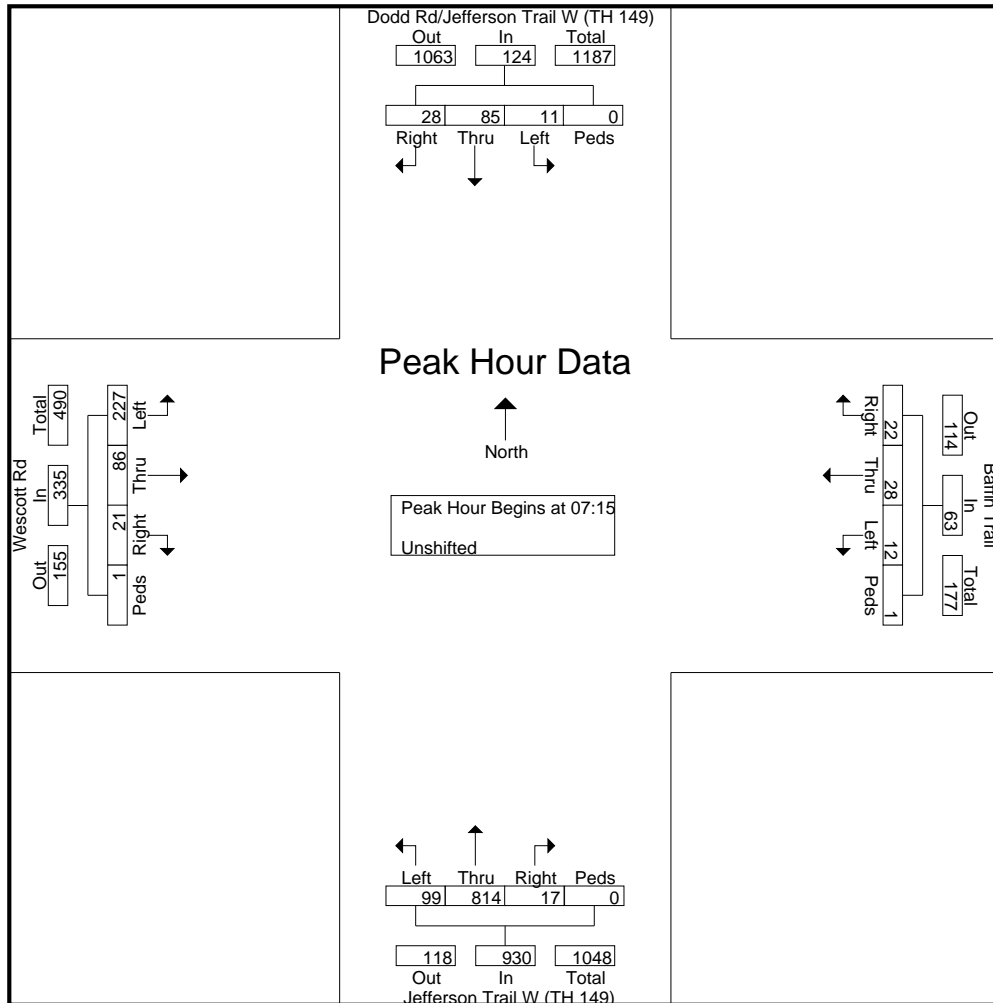

# Alliant Engineering Inc Minneapolis, MN 55415

TH-149 at Wescott Rd / Baffin Trail  
 Ref.Pt.: 000.834  
 Alliant Engineering Inc  
 TURN MOVEMENT COUNT

File Name : 19\_TH 149 at Wescott Rd\_030410  
 Site Code : 00000019  
 Start Date : 3/4/2010  
 Page No : 4

Start Time	Dodd Rd/Jefferson Trail W (TH 149) Southbound					Baffin Trail Westbound					Jefferson Trail W (TH 149) Northbound					Wescott Rd Eastbound					Int. Total
	Left	Thru	Right	Peds	App. Total	Left	Thru	Right	Peds	App. Total	Left	Thru	Right	Peds	App. Total	Left	Thru	Right	Peds	App. Total	
16:45	5	141	43	0	189	10	21	1	0	32	10	29	8	0	47	12	19	2	1	34	302
17:00	0	92	41	0	133	16	24	1	0	41	15	44	7	0	66	8	25	6	0	39	279
17:15	3	116	59	2	180	11	29	2	0	42	1	41	9	0	51	9	26	11	0	46	319
17:30	1	178	60	0	239	7	17	1	0	25	9	43	3	0	55	28	22	9	0	59	378
Total Volume	9	527	203	2	741	44	91	5	0	140	35	157	27	0	219	57	92	28	1	178	1278
% App. Total	1.2	71.1	27.4	0.3		31.4	65	3.6	0		16	71.7	12.3	0		32	51.7	15.7	0.6		
PHF	.450	.740	.846	.250	.775	.688	.784	.625	.000	.833	.583	.892	.750	.000	.830	.509	.885	.636	.250	.754	.845

Peak Hour Analysis From 15:00 to 17:45 - Peak 1 of 1  
 Peak Hour for Entire Intersection Begins at 16:45

