

TRAFFIC DATA INC.

3268 Xenwood Ave S
St Louis Park, MN 55416

TH-13 at Cliff Rd E / CSAH-32
Ref.Pt.: 100.018
Data by: Traffic Data Inc.
TURN MOVEMENT COUNT

File Name : TH-13 at Cliff Rd E CSAH-32 2009
Site Code : 01829134
Start Date : 5/7/2009
Page No : 1

Groups Printed- Unshifted

| Start Time | TH-13 Southbound | | | | Cliff Rd E / CSAH-32 Westbound | | | | TH-13 Northbound | | | | Cliff Rd E / CSAH-32 Eastbound | | | | Int. Total |
|---------------|------------------|------|-------|------|--------------------------------|------|-------|------|------------------|------|-------|------|--------------------------------|------|-------|------|------------|
| | Left | Thru | Right | Peds | Left | Thru | Right | Peds | Left | Thru | Right | Peds | Left | Thru | Right | Peds | |
| 06:00 | 8 | 47 | 17 | 0 | 39 | 58 | 1 | 0 | 1 | 108 | 38 | 0 | 14 | 25 | 1 | 0 | 357 |
| 06:15 | 3 | 64 | 13 | 0 | 48 | 73 | 2 | 1 | 0 | 139 | 57 | 0 | 17 | 18 | 0 | 0 | 435 |
| 06:30 | 1 | 79 | 18 | 0 | 68 | 90 | 5 | 1 | 3 | 206 | 66 | 1 | 16 | 27 | 1 | 0 | 582 |
| 06:45 | 6 | 111 | 28 | 0 | 74 | 115 | 8 | 0 | 1 | 229 | 63 | 1 | 12 | 34 | 1 | 0 | 683 |
| Total | 18 | 301 | 76 | 0 | 229 | 336 | 16 | 2 | 5 | 682 | 224 | 2 | 59 | 104 | 3 | 0 | 2057 |
| 07:00 | 4 | 137 | 43 | 1 | 97 | 130 | 12 | 0 | 3 | 261 | 96 | 0 | 32 | 32 | 0 | 0 | 848 |
| 07:15 | 5 | 136 | 52 | 0 | 87 | 126 | 22 | 0 | 1 | 341 | 79 | 0 | 46 | 52 | 0 | 0 | 947 |
| 07:30 | 7 | 155 | 47 | 1 | 102 | 128 | 20 | 0 | 5 | 444 | 83 | 1 | 37 | 49 | 0 | 0 | 1079 |
| 07:45 | 7 | 148 | 53 | 0 | 101 | 148 | 20 | 0 | 9 | 380 | 64 | 0 | 32 | 54 | 0 | 0 | 1016 |
| Total | 23 | 576 | 195 | 2 | 387 | 532 | 74 | 0 | 18 | 1426 | 322 | 1 | 147 | 187 | 0 | 0 | 3890 |
| 08:00 | 10 | 136 | 53 | 0 | 81 | 133 | 17 | 0 | 5 | 300 | 75 | 1 | 35 | 53 | 1 | 1 | 901 |
| 08:15 | 7 | 142 | 36 | 0 | 92 | 105 | 19 | 0 | 10 | 300 | 79 | 0 | 23 | 54 | 0 | 0 | 867 |
| 08:30 | 5 | 149 | 35 | 0 | 75 | 96 | 5 | 0 | 4 | 246 | 63 | 0 | 25 | 49 | 2 | 0 | 754 |
| 08:45 | 10 | 160 | 38 | 0 | 80 | 72 | 9 | 0 | 3 | 199 | 89 | 0 | 19 | 60 | 1 | 0 | 740 |
| Total | 32 | 587 | 162 | 0 | 328 | 406 | 50 | 0 | 22 | 1045 | 306 | 1 | 102 | 216 | 4 | 1 | 3262 |
| *** BREAK *** | | | | | | | | | | | | | | | | | |
| 11:00 | 8 | 109 | 23 | 1 | 65 | 73 | 7 | 0 | 11 | 116 | 63 | 0 | 24 | 72 | 1 | 0 | 573 |
| 11:15 | 4 | 126 | 17 | 0 | 40 | 45 | 8 | 0 | 6 | 140 | 72 | 1 | 29 | 79 | 3 | 0 | 570 |
| 11:30 | 11 | 107 | 23 | 0 | 63 | 71 | 2 | 0 | 4 | 129 | 63 | 0 | 25 | 104 | 4 | 0 | 606 |
| 11:45 | 22 | 130 | 26 | 0 | 59 | 62 | 12 | 0 | 8 | 128 | 84 | 0 | 30 | 97 | 3 | 0 | 661 |
| Total | 45 | 472 | 89 | 1 | 227 | 251 | 29 | 0 | 29 | 513 | 282 | 1 | 108 | 352 | 11 | 0 | 2410 |
| 12:00 | 5 | 119 | 31 | 1 | 79 | 107 | 8 | 1 | 7 | 122 | 73 | 0 | 34 | 114 | 1 | 0 | 702 |
| 12:15 | 14 | 127 | 33 | 0 | 69 | 73 | 12 | 1 | 13 | 131 | 91 | 1 | 26 | 107 | 3 | 0 | 701 |
| 12:30 | 12 | 122 | 30 | 1 | 61 | 110 | 13 | 0 | 2 | 130 | 94 | 0 | 35 | 86 | 5 | 0 | 701 |
| 12:45 | 10 | 106 | 17 | 1 | 52 | 97 | 10 | 1 | 7 | 115 | 73 | 0 | 31 | 76 | 3 | 0 | 599 |
| Total | 41 | 474 | 111 | 3 | 261 | 387 | 43 | 3 | 29 | 498 | 331 | 1 | 126 | 383 | 12 | 0 | 2703 |
| *** BREAK *** | | | | | | | | | | | | | | | | | |
| 15:00 | 15 | 221 | 40 | 2 | 75 | 82 | 16 | 2 | 12 | 161 | 121 | 0 | 47 | 126 | 4 | 1 | 925 |
| 15:15 | 14 | 203 | 22 | 2 | 85 | 63 | 9 | 1 | 5 | 136 | 87 | 4 | 38 | 96 | 2 | 1 | 768 |
| 15:30 | 11 | 201 | 21 | 0 | 77 | 91 | 9 | 0 | 11 | 172 | 121 | 0 | 47 | 138 | 4 | 1 | 904 |
| 15:45 | 16 | 292 | 46 | 1 | 104 | 71 | 7 | 0 | 11 | 182 | 109 | 0 | 39 | 124 | 2 | 0 | 1004 |
| Total | 56 | 917 | 129 | 5 | 341 | 307 | 41 | 3 | 39 | 651 | 438 | 4 | 171 | 484 | 12 | 3 | 3601 |
| 16:00 | 15 | 282 | 35 | 0 | 85 | 74 | 15 | 0 | 5 | 186 | 124 | 0 | 56 | 128 | 3 | 0 | 1008 |
| 16:15 | 15 | 311 | 31 | 0 | 97 | 62 | 14 | 0 | 10 | 176 | 135 | 0 | 44 | 106 | 5 | 0 | 1006 |
| 16:30 | 9 | 204 | 138 | 17 | 91 | 66 | 11 | 1 | 4 | 238 | 141 | 2 | 56 | 157 | 2 | 0 | 1137 |
| 16:45 | 22 | 390 | 38 | 0 | 106 | 84 | 10 | 0 | 12 | 210 | 144 | 0 | 42 | 140 | 1 | 0 | 1199 |
| Total | 61 | 1187 | 242 | 17 | 379 | 286 | 50 | 1 | 31 | 810 | 544 | 2 | 198 | 531 | 11 | 0 | 4350 |
| 17:00 | 16 | 369 | 34 | 2 | 111 | 75 | 15 | 1 | 8 | 172 | 114 | 0 | 60 | 187 | 6 | 1 | 1171 |
| 17:15 | 19 | 385 | 43 | 0 | 97 | 71 | 12 | 0 | 8 | 145 | 113 | 0 | 54 | 152 | 2 | 0 | 1101 |
| 17:30 | 13 | 332 | 24 | 2 | 93 | 70 | 6 | 0 | 11 | 195 | 140 | 1 | 52 | 128 | 2 | 3 | 1072 |
| 17:45 | 18 | 273 | 25 | 3 | 106 | 72 | 10 | 3 | 6 | 261 | 171 | 1 | 38 | 126 | 0 | 0 | 1113 |
| Total | 66 | 1359 | 126 | 7 | 407 | 288 | 43 | 4 | 33 | 773 | 538 | 2 | 204 | 593 | 10 | 4 | 4457 |
| Grand Total | 342 | 5873 | 1130 | 35 | 2559 | 2793 | 346 | 13 | 206 | 6398 | 2985 | 14 | 1115 | 2850 | 63 | 8 | 26730 |
| Apprch % | 4.6 | 79.6 | 15.3 | 0.5 | 44.8 | 48.9 | 6.1 | 0.2 | 2.1 | 66.6 | 31.1 | 0.1 | 27.6 | 70.6 | 1.6 | 0.2 | |
| Total % | 1.3 | 22 | 4.2 | 0.1 | 9.6 | 10.4 | 1.3 | 0 | 0.8 | 23.9 | 11.2 | 0.1 | 4.2 | 10.7 | 0.2 | 0 | |

TRAFFIC DATA INC.

3268 Xenwood Ave S
St Louis Park, MN 55416

TH-13 at Cliff Rd E / CSAH-32
Ref.Pt.: 100.018
Data by: Traffic Data Inc.
TURN MOVEMENT COUNT

File Name : TH-13 at Cliff Rd E CSAH-32 2009
Site Code : 01829134
Start Date : 5/7/2009
Page No : 2

| Start Time | TH-13 Southbound | | | | | Cliff Rd E / CSAH-32 Westbound | | | | | TH-13 Northbound | | | | | Cliff Rd E / CSAH-32 Eastbound | | | | | Int. Total |
|--|------------------|------|-------|------|------------|--------------------------------|------|-------|------|------------|------------------|------|-------|------|------------|--------------------------------|------|-------|------|------------|------------|
| | Left | Thru | Right | Peds | App. Total | Left | Thru | Right | Peds | App. Total | Left | Thru | Right | Peds | App. Total | Left | Thru | Right | Peds | App. Total | |
| Peak Hour Analysis From 06:00 to 08:45 - Peak 1 of 1 | | | | | | | | | | | | | | | | | | | | | |
| Peak Hour for Entire Intersection Begins at 07:15 | | | | | | | | | | | | | | | | | | | | | |
| 07:15 | 5 | 136 | 52 | 0 | 193 | 87 | 126 | 22 | 0 | 235 | 1 | 341 | 79 | 0 | 421 | 46 | 52 | 0 | 0 | 98 | 947 |
| 07:30 | 7 | 155 | 47 | 1 | 210 | 102 | 128 | 20 | 0 | 250 | 5 | 444 | 83 | 1 | 533 | 37 | 49 | 0 | 0 | 86 | 1079 |
| 07:45 | 7 | 148 | 53 | 0 | 208 | 101 | 148 | 20 | 0 | 269 | 9 | 380 | 64 | 0 | 453 | 32 | 54 | 0 | 0 | 86 | 1016 |
| 08:00 | 10 | 136 | 53 | 0 | 199 | 81 | 133 | 17 | 0 | 231 | 5 | 300 | 75 | 1 | 381 | 35 | 53 | 1 | 1 | 90 | 901 |
| Total Volume | 29 | 575 | 205 | 1 | 810 | 371 | 535 | 79 | 0 | 985 | 20 | 1465 | 301 | 2 | 1788 | 150 | 208 | 1 | 1 | 360 | 3943 |
| % App. Total | 3.6 | 71 | 25.3 | 0.1 | | 37.7 | 54.3 | 8 | 0 | | 1.1 | 81.9 | 16.8 | 0.1 | | 41.7 | 57.8 | 0.3 | 0.3 | | |
| PHF | .725 | .927 | .967 | .250 | .964 | .909 | .904 | .898 | .000 | .915 | .556 | .825 | .907 | .500 | .839 | .815 | .963 | .250 | .250 | .918 | .914 |

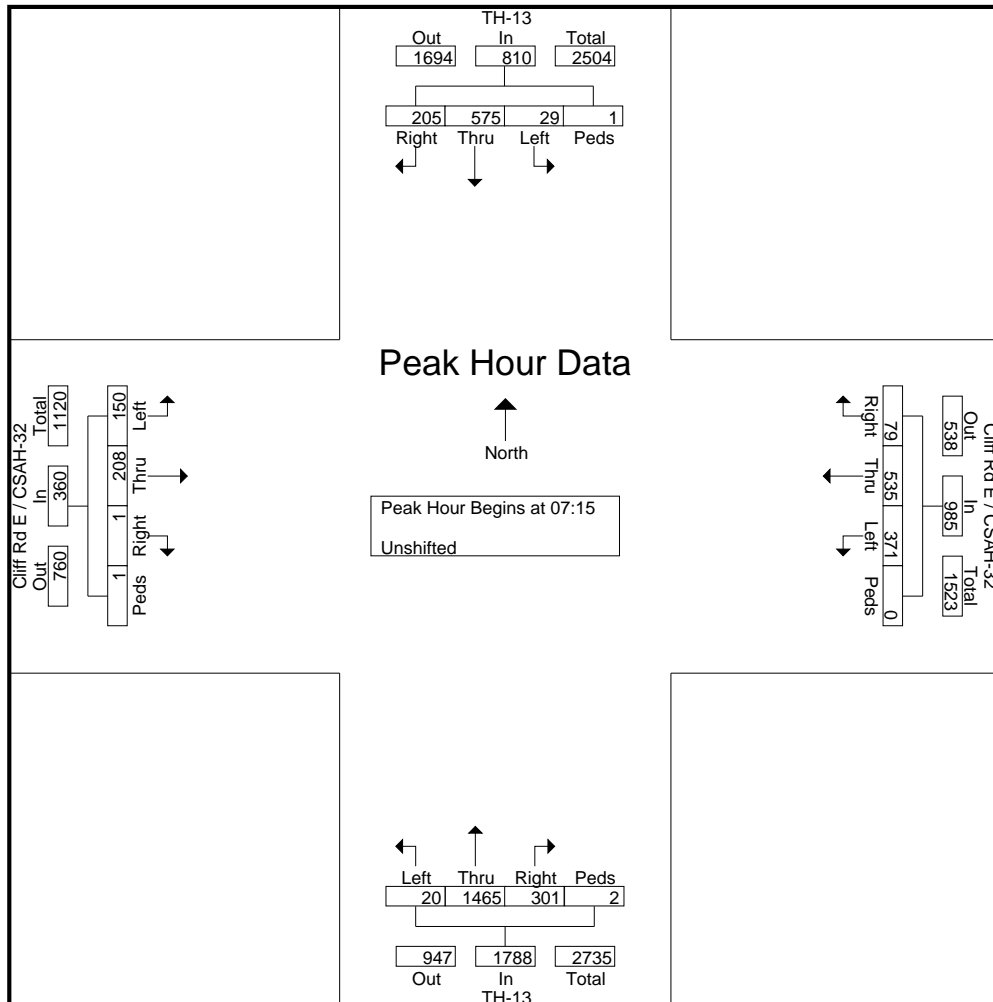

TRAFFIC DATA INC.

3268 Xenwood Ave S
St Louis Park, MN 55416

TH-13 at Cliff Rd E / CSAH-32
Ref.Pt.: 100.018
Data by: Traffic Data Inc.
TURN MOVEMENT COUNT

File Name : TH-13 at Cliff Rd E CSAH-32 2009
Site Code : 01829134
Start Date : 5/7/2009
Page No : 3

| Start Time | TH-13 Southbound | | | | | Cliff Rd E / CSAH-32 Westbound | | | | | TH-13 Northbound | | | | | Cliff Rd E / CSAH-32 Eastbound | | | | | Int. Total |
|--|------------------|------|-------|------|------------|--------------------------------|------|-------|------|------------|------------------|------|-------|------|------------|--------------------------------|------|-------|------|------------|------------|
| | Left | Thru | Right | Peds | App. Total | Left | Thru | Right | Peds | App. Total | Left | Thru | Right | Peds | App. Total | Left | Thru | Right | Peds | App. Total | |
| Peak Hour Analysis From 15:00 to 17:45 - Peak 1 of 1 | | | | | | | | | | | | | | | | | | | | | |
| Peak Hour for Entire Intersection Begins at 16:30 | | | | | | | | | | | | | | | | | | | | | |
| 16:30 | 9 | 204 | 138 | 17 | 368 | 91 | 66 | 11 | 1 | 169 | 4 | 238 | 141 | 2 | 385 | 56 | 157 | 2 | 0 | 215 | 1137 |
| 16:45 | 22 | 390 | 38 | 0 | 450 | 106 | 84 | 10 | 0 | 200 | 12 | 210 | 144 | 0 | 366 | 42 | 140 | 1 | 0 | 183 | 1199 |
| 17:00 | 16 | 369 | 34 | 2 | 421 | 111 | 75 | 15 | 1 | 202 | 8 | 172 | 114 | 0 | 294 | 60 | 187 | 6 | 1 | 254 | 1171 |
| 17:15 | 19 | 385 | 43 | 0 | 447 | 97 | 71 | 12 | 0 | 180 | 8 | 145 | 113 | 0 | 266 | 54 | 152 | 2 | 0 | 208 | 1101 |
| Total Volume | 66 | 1348 | 253 | 19 | 1686 | 405 | 296 | 48 | 2 | 751 | 32 | 765 | 512 | 2 | 1311 | 212 | 636 | 11 | 1 | 860 | 4608 |
| % App. Total | 3.9 | 80 | 15 | 1.1 | | 53.9 | 39.4 | 6.4 | 0.3 | | 2.4 | 58.4 | 39.1 | 0.2 | | 24.7 | 74 | 1.3 | 0.1 | | |
| PHF | .750 | .864 | .458 | .279 | .937 | .912 | .881 | .800 | .500 | .929 | .667 | .804 | .889 | .250 | .851 | .883 | .850 | .458 | .250 | .846 | .961 |

