



# MINNESOTA DEPT OF TRANSPORTATION

## TRAFFIC DATA COLLECTION - METRO

TH-13 at McColl Drive / CSAH-16  
 Ref.Pt.: 089.532 SAVAGE  
 JAMAR # D4-3365 CH  
 TURN MOVEMENT COUNT

File Name : TH-13 at McColl Drive 2008  
 Site Code : 00000000  
 Start Date : 12/10/2008  
 Page No : 1

### Groups Printed- Cars & Trucks

Start Time	TH-13 Southbound				McColl Dr / CSAH-16 Westbound				TH-13 Northbound				McColl Dr / CSAH-16 Eastbound				Int. Total
	Left	Thru	Right	Peds	Left	Thru	Right	Peds	Left	Thru	Right	Peds	Left	Thru	Right	Peds	
06:00	11	19	0	0	2	22	73	0	2	144	4	0	0	11	1	0	289
06:15	14	29	1	0	3	21	107	0	4	196	8	0	4	24	5	0	416
06:30	10	59	0	0	6	39	162	0	6	247	15	0	8	26	7	0	585
06:45	12	63	1	0	7	30	121	0	9	258	19	0	9	39	13	0	581
Total	47	170	2	0	18	112	463	0	21	845	46	0	21	100	26	0	1871
07:00	18	56	2	0	8	36	172	0	12	295	20	0	5	30	2	0	656
07:15	26	64	4	0	11	50	159	0	9	265	33	0	11	54	9	0	695
07:30	26	73	0	0	9	65	124	0	16	224	27	0	4	41	8	0	617
07:45	27	75	3	0	10	55	114	3	15	208	30	0	6	52	4	0	602
Total	97	268	9	0	38	206	569	3	52	992	110	0	26	177	23	0	2570
08:00	29	58	3	0	8	47	109	0	9	174	14	0	7	41	10	0	509
08:15	23	71	6	0	8	35	110	0	13	213	22	0	14	32	16	0	563
08:30	26	84	3	0	7	32	80	0	8	176	16	0	6	33	6	0	477
08:45	21	79	1	0	10	27	72	0	9	190	27	0	5	60	9	0	510
Total	99	292	13	0	33	141	371	0	39	753	79	0	32	166	41	0	2059
*** BREAK ***																	
15:00	38	133	5	0	26	39	34	0	7	91	13	0	5	34	18	0	443
15:15	82	171	9	0	20	31	34	0	16	98	25	0	7	54	17	0	564
15:30	78	195	8	0	25	34	21	0	17	106	16	0	4	48	15	0	567
15:45	85	217	5	0	32	67	32	0	22	98	13	0	4	58	17	0	650
Total	283	716	27	0	103	171	121	0	62	393	67	0	20	194	67	0	2224
16:00	100	228	7	0	25	32	39	0	10	88	10	0	3	53	23	0	618
16:15	104	222	14	0	19	40	32	0	15	85	26	0	5	52	26	0	640
16:30	97	210	10	0	22	34	21	0	17	112	17	0	0	101	27	0	668
16:45	122	231	14	0	34	39	27	0	14	88	28	0	6	84	28	0	715
Total	423	891	45	0	100	145	119	0	56	373	81	0	14	290	104	0	2641
17:00	113	262	12	0	19	62	30	0	16	120	15	0	6	84	32	1	772
17:15	136	254	26	0	20	46	25	1	17	107	27	0	3	98	28	0	788
17:30	98	220	15	0	20	38	24	0	12	109	16	0	9	90	26	0	677
17:45	112	272	25	0	21	30	24	0	21	101	15	0	2	70	11	0	704
Total	459	1008	78	0	80	176	103	1	66	437	73	0	20	342	97	1	2941
Grand Total	1408	3345	174	0	372	951	1746	4	296	3793	456	0	133	1269	358	1	14306
Apprch %	28.6	67.9	3.5	0	12.1	30.9	56.8	0.1	6.5	83.5	10	0	7.6	72.1	20.3	0.1	
Total %	9.8	23.4	1.2	0	2.6	6.6	12.2	0	2.1	26.5	3.2	0	0.9	8.9	2.5	0	



# MINNESOTA DEPT OF TRANSPORTATION

## TRAFFIC DATA COLLECTION - METRO

TH-13 at McColl Drive / CSAH-16  
 Ref.Pt.: 089.532 SAVAGE  
 JAMAR # D4-3365 CH  
 TURN MOVEMENT COUNT

File Name : TH-13 at McColl Drive 2008  
 Site Code : 00000000  
 Start Date : 12/10/2008  
 Page No : 2

Start Time	TH-13 Southbound					McColl Dr / CSAH-16 Westbound					TH-13 Northbound					McColl Dr / CSAH-16 Eastbound					Int. Total
	Left	Thru	Right	Peds	App. Total	Left	Thru	Right	Peds	App. Total	Left	Thru	Right	Peds	App. Total	Left	Thru	Right	Peds	App. Total	
Peak Hour Analysis From 06:00 to 08:45 - Peak 1 of 1																					
Peak Hour for Entire Intersection Begins at 07:00																					
07:00	18	56	2	0	76	8	36	172	0	216	12	295	20	0	327	5	30	2	0	37	656
07:15	26	64	4	0	94	11	50	159	0	220	9	265	33	0	307	11	54	9	0	74	695
07:30	26	73	0	0	99	9	65	124	0	198	16	224	27	0	267	4	41	8	0	53	617
07:45	27	75	3	0	105	10	55	114	3	182	15	208	30	0	253	6	52	4	0	62	602
Total Volume	97	268	9	0	374	38	206	569	3	816	52	992	110	0	1154	26	177	23	0	226	2570
% App. Total	25.9	71.7	2.4	0		4.7	25.2	69.7	0.4		4.5	86	9.5	0		11.5	78.3	10.2	0		
PHF	.898	.893	.563	.000	.890	.864	.792	.827	.250	.927	.813	.841	.833	.000	.882	.591	.819	.639	.000	.764	.924

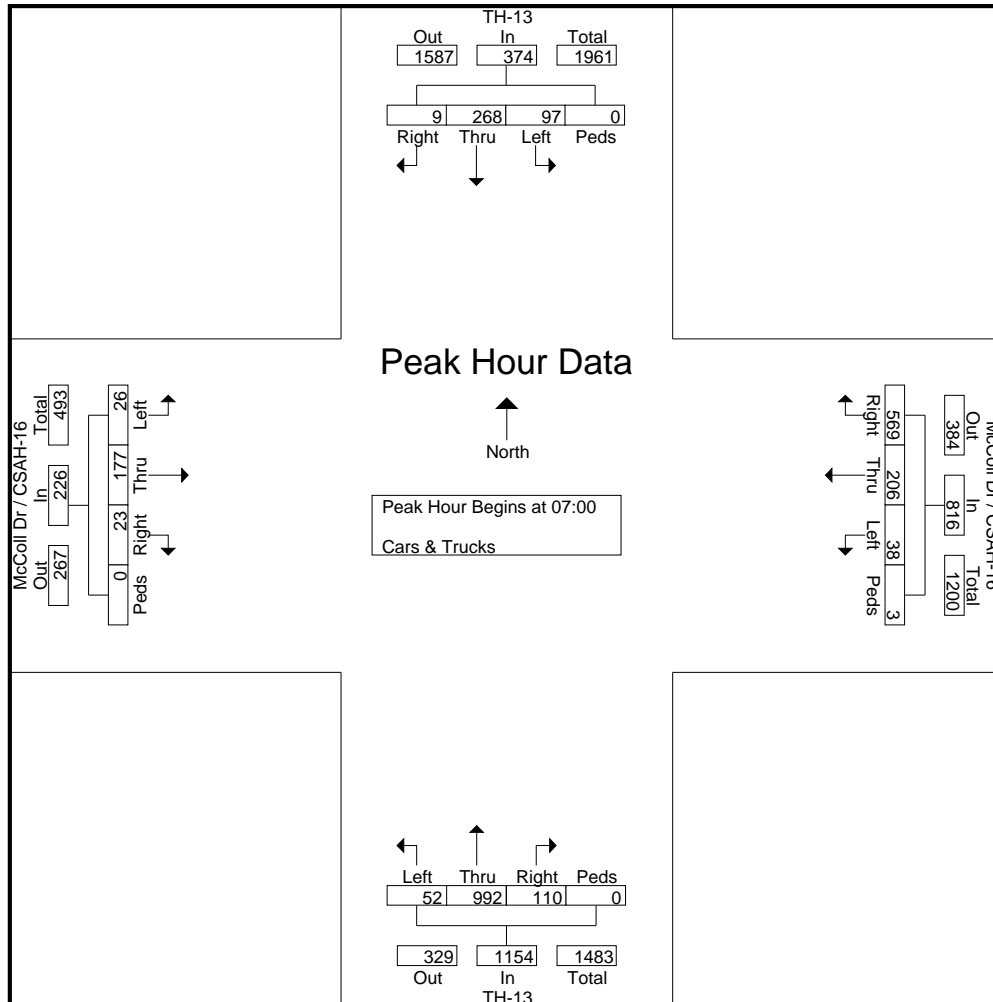



# MINNESOTA DEPT OF TRANSPORTATION

## TRAFFIC DATA COLLECTION - METRO

TH-13 at McColl Drive / CSAH-16  
 Ref.Pt.: 089.532 SAVAGE  
 JAMAR # D4-3365 CH  
 TURN MOVEMENT COUNT

File Name : TH-13 at McColl Drive 2008  
 Site Code : 00000000  
 Start Date : 12/10/2008  
 Page No : 3

Start Time	TH-13 Southbound					McColl Dr / CSAH-16 Westbound					TH-13 Northbound					McColl Dr / CSAH-16 Eastbound					Int. Total
	Left	Thru	Right	Peds	App. Total	Left	Thru	Right	Peds	App. Total	Left	Thru	Right	Peds	App. Total	Left	Thru	Right	Peds	App. Total	

Peak Hour Analysis From 15:00 to 17:45 - Peak 1 of 1  
 Peak Hour for Entire Intersection Begins at 16:45

16:45	122	231	14	0	367	34	39	27	0	100	14	88	28	0	130	6	84	28	0	118	715
17:00	113	262	12	0	387	19	62	30	0	111	16	120	15	0	151	6	84	32	1	123	772
17:15	136	254	26	0	416	20	46	25	1	92	17	107	27	0	151	3	98	28	0	129	788
17:30	98	220	15	0	333	20	38	24	0	82	12	109	16	0	137	9	90	26	0	125	677
Total Volume	469	967	67	0	1503	93	185	106	1	385	59	424	86	0	569	24	356	114	1	495	2952
% App. Total	31.2	64.3	4.5	0		24.2	48.1	27.5	0.3		10.4	74.5	15.1	0		4.8	71.9	23	0.2		
PHF	.862	.923	.644	.000	.903	.684	.746	.883	.250	.867	.868	.883	.768	.000	.942	.667	.908	.891	.250	.959	.937

