



MINNESOTA DEPT OF TRANSPORTATION

TRAFFIC DATA COLLECTION - METRO

TH-101 at Pleasant View Rd
 Ref.Pt.: 015.307
 JAMAR # T-2638 CAH
 TURN MOVEMENT COUNT

File Name : TH-101 at Pleasant View Rd 2010
 Site Code : 00000000
 Start Date : 1/14/2010
 Page No : 1

Groups Printed- Cars & Trucks

Start Time	TH-101 / W 192nd Ave Southbound				PLEASANT VIEW RD Westbound				TH-101 / W 192nd Ave Northbound				PLEASANT VIEW RD Eastbound				Int. Total
	Left	Thru	Right	Peds	Left	Thru	Right	Peds	Left	Thru	Right	Peds	Left	Thru	Right	Peds	
06:00	0	15	1	0	1	0	0	0	0	23	0	0	7	1	1	0	49
06:15	0	19	1	0	0	1	0	0	0	27	0	0	4	1	3	0	56
06:30	0	32	2	2	2	0	0	0	0	54	1	0	20	0	2	0	115
06:45	0	41	1	0	3	0	0	0	0	57	1	0	25	2	7	0	137
Total	0	107	5	2	6	1	0	0	0	161	2	0	56	4	13	0	357
07:00	0	40	3	0	3	0	2	0	3	88	1	0	28	2	8	0	178
07:15	0	56	6	0	0	0	2	0	3	106	2	0	43	0	7	0	225
07:30	0	67	3	0	0	1	1	0	1	152	2	0	36	4	9	0	276
07:45	0	80	5	0	1	2	3	0	5	134	1	0	31	3	10	0	275
Total	0	243	17	0	4	3	8	0	12	480	6	0	138	9	34	0	954
08:00	2	61	7	0	0	0	0	0	4	105	3	0	30	1	11	0	224
08:15	1	68	6	0	2	0	0	0	2	110	0	0	25	2	8	0	224
08:30	0	68	11	0	2	2	0	0	3	79	0	0	27	0	9	0	201
08:45	1	60	6	0	1	2	0	0	4	60	3	0	24	2	9	0	172
Total	4	257	30	0	5	4	0	0	13	354	6	0	106	5	37	0	821
*** BREAK ***																	
15:00	0	104	16	0	3	2	1	0	2	74	1	0	9	0	5	0	217
15:15	0	90	20	0	0	2	0	0	11	72	8	0	17	2	3	0	225
15:30	2	94	17	0	4	3	0	1	8	66	2	0	15	1	2	0	215
15:45	0	92	13	0	2	1	2	1	4	94	1	0	6	1	6	0	223
Total	2	380	66	0	9	8	3	2	25	306	12	0	47	4	16	0	880
16:00	0	94	22	0	1	0	0	0	8	85	3	0	4	1	3	0	221
16:15	1	91	25	0	3	0	1	0	7	87	2	0	14	1	10	0	242
16:30	0	106	30	0	1	1	0	0	10	79	2	0	9	0	6	0	244
16:45	1	108	21	0	6	2	2	0	3	75	6	0	22	0	4	0	250
Total	2	399	98	0	11	3	3	0	28	326	13	0	49	2	23	0	957
17:00	0	141	34	0	3	0	1	0	11	84	3	0	13	4	8	0	302
17:15	4	173	47	0	3	1	0	0	13	99	6	0	9	0	3	0	358
17:30	1	106	52	0	2	2	0	0	14	80	1	0	14	5	5	0	282
17:45	1	128	28	0	2	2	0	0	17	78	4	0	8	3	11	0	282
Total	6	548	161	0	10	5	1	0	55	341	14	0	44	12	27	0	1224
Grand Total	14	1934	377	2	45	24	15	2	133	1968	53	0	440	36	150	0	5193
Apprch %	0.6	83.1	16.2	0.1	52.3	27.9	17.4	2.3	6.2	91.4	2.5	0	70.3	5.8	24	0	
Total %	0.3	37.2	7.3	0	0.9	0.5	0.3	0	2.6	37.9	1	0	8.5	0.7	2.9	0	

Left turning traffic, EB TH-101, had no problems and no backups. At TH-101 the PM was the tight one at 5 PM - EB Pleasant View Rd had about 6 cars in line which made it difficult for SB TH-101 cars to make the right turn onto Pleasant View Rd., therefore stacking cars in the right turn lane. NB cars drive like they don't know how: cars turning left on to Pleasant View Rd had to wait for a break, but other cars would try to get around them even if there was a car turning right on to Pleasant View Rd. At this location there is No right turn lane northbound.
 CAH



MINNESOTA DEPT OF TRANSPORTATION

TRAFFIC DATA COLLECTION - METRO

TH-101 at Pleasant View Rd
 Ref.Pt.: 015.307
 JAMAR # T-2638 CAH
 TURN MOVEMENT COUNT

File Name : TH-101 at Pleasant View Rd 2010
 Site Code : 00000000
 Start Date : 1/14/2010
 Page No : 2

Start Time	TH-101 / W 192nd Ave Southbound					PLEASANT VIEW RD Westbound					TH-101 / W 192nd Ave Northbound					PLEASANT VIEW RD Eastbound					Int. Total
	Left	Thru	Right	Peds	App. Total	Left	Thru	Right	Peds	App. Total	Left	Thru	Right	Peds	App. Total	Left	Thru	Right	Peds	App. Total	
Peak Hour Analysis From 06:00 to 08:45 - Peak 1 of 1																					
Peak Hour for Entire Intersection Begins at 07:15																					
07:15	0	56	6	0	62	0	0	2	0	2	3	106	2	0	111	43	0	7	0	50	225
07:30	0	67	3	0	70	0	1	1	0	2	1	152	2	0	155	36	4	9	0	49	276
07:45	0	80	5	0	85	1	2	3	0	6	5	134	1	0	140	31	3	10	0	44	275
08:00	2	61	7	0	70	0	0	0	0	0	4	105	3	0	112	30	1	11	0	42	224
Total Volume	2	264	21	0	287	1	3	6	0	10	13	497	8	0	518	140	8	37	0	185	1000
% App. Total	0.7	92	7.3	0		10	30	60	0		2.5	95.9	1.5	0		75.7	4.3	20	0		
PHF	.250	.825	.750	.000	.844	.250	.375	.500	.000	.417	.650	.817	.667	.000	.835	.814	.500	.841	.000	.925	.906

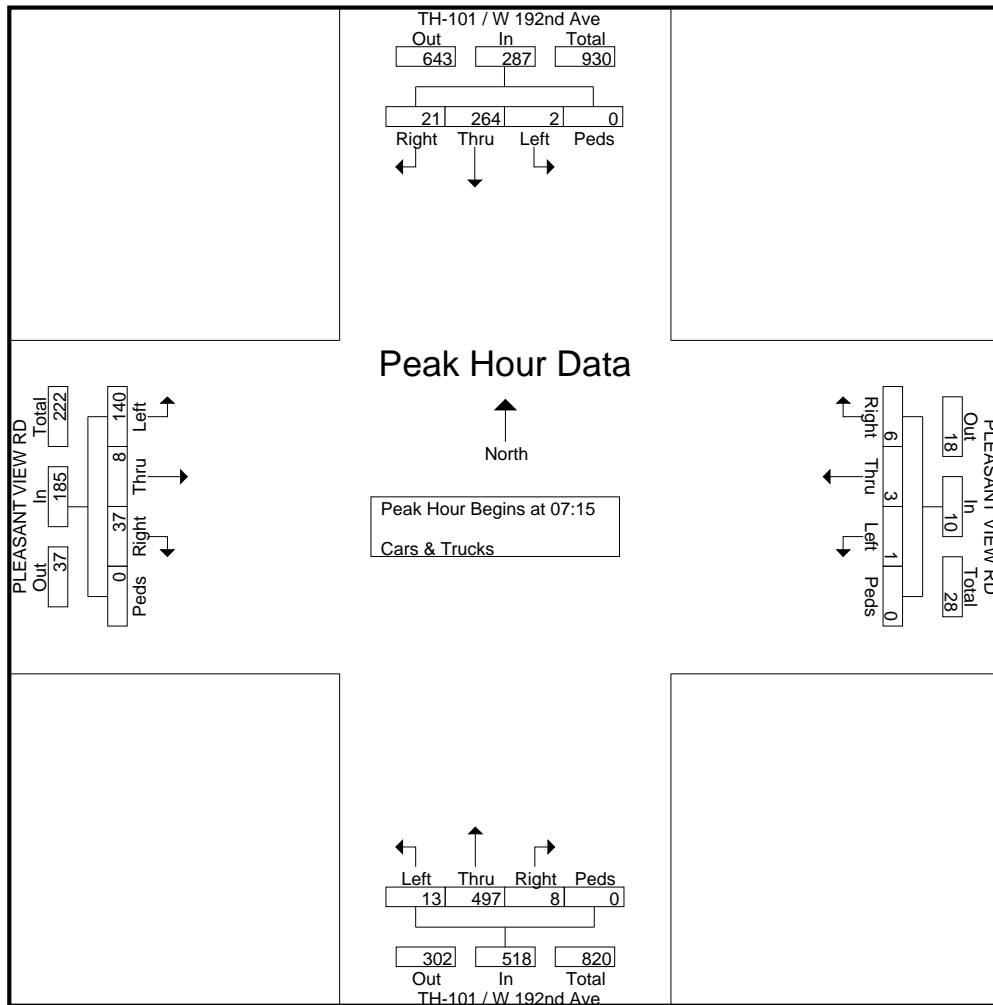



MINNESOTA DEPT OF TRANSPORTATION

TRAFFIC DATA COLLECTION - METRO

TH-101 at Pleasant View Rd
 Ref.Pt.: 015.307
 JAMAR # T-2638 CAH
 TURN MOVEMENT COUNT

File Name : TH-101 at Pleasant View Rd 2010
 Site Code : 00000000
 Start Date : 1/14/2010
 Page No : 3

Start Time	TH-101 / W 192nd Ave Southbound					PLEASANT VIEW RD Westbound					TH-101 / W 192nd Ave Northbound					PLEASANT VIEW RD Eastbound					Int. Total
	Left	Thru	Right	Peds	App. Total	Left	Thru	Right	Peds	App. Total	Left	Thru	Right	Peds	App. Total	Left	Thru	Right	Peds	App. Total	

Peak Hour Analysis From 15:00 to 17:45 - Peak 1 of 1
 Peak Hour for Entire Intersection Begins at 17:00

17:00	0	141	34	0	175	3	0	1	0	4	11	84	3	0	98	13	4	8	0	25	302
17:15	4	173	47	0	224	3	1	0	0	4	13	99	6	0	118	9	0	3	0	12	358
17:30	1	106	52	0	159	2	2	0	0	4	14	80	1	0	95	14	5	5	0	24	282
17:45	1	128	28	0	157	2	2	0	0	4	17	78	4	0	99	8	3	11	0	22	282
Total Volume	6	548	161	0	715	10	5	1	0	16	55	341	14	0	410	44	12	27	0	83	1224
% App. Total	0.8	76.6	22.5	0		62.5	31.2	6.2	0		13.4	83.2	3.4	0		53	14.5	32.5	0		
PHF	.375	.792	.774	.000	.798	.833	.625	.250	.000	1.000	.809	.861	.583	.000	.869	.786	.600	.614	.000	.830	.855

