



MINNESOTA DEPT OF TRANSPORTATION

TRAFFIC DATA COLLECTION - METRO

I-494 at Portland Ave., North Ramps
 Ref.Pt.: 003.848
 JAMAR # T-2638 CAH
 TURN MOVEMENT COUNT

File Name : I-494 at Portland Ave north ramps 2010
 Site Code : 00000000
 Start Date : 10/6/2010
 Page No : 1

Groups Printed- Cars & Trucks

Start Time	Portland Ave. Southbound				ramp from WB I-494 Westbound				Portland Ave. Northbound				ramp to WB I-494 Eastbound				Int. Total
	Left	Thru	Right	Peds	Left	Thru	Right	Peds	Left	Thru	Right	Peds	Left	Thru	Right	Peds	
06:00	0	21	19	0	2	36	8	0	25	38	0	2	0	0	0	0	151
06:15	0	27	23	0	8	31	7	0	35	35	0	1	0	0	0	0	167
06:30	0	19	28	0	11	41	5	0	49	47	0	0	0	0	0	0	200
06:45	0	35	21	0	22	30	12	0	39	46	0	1	0	0	0	0	206
Total	0	102	91	0	43	138	32	0	148	166	0	4	0	0	0	0	724
07:00	0	49	22	0	23	31	13	0	38	58	0	4	0	0	0	0	238
07:15	0	52	31	0	35	38	22	0	30	87	0	0	0	0	0	0	295
07:30	0	80	34	4	24	50	31	2	21	97	0	1	0	0	0	1	345
07:45	0	88	21	0	31	23	39	0	23	86	0	4	0	0	0	0	315
Total	0	269	108	4	113	142	105	2	112	328	0	9	0	0	0	1	1193
08:00	0	62	15	0	21	25	39	0	22	66	0	1	0	0	0	0	251
08:15	0	63	17	0	37	37	38	0	24	56	0	9	0	0	0	0	281
08:30	0	65	16	0	30	29	47	0	28	76	0	6	0	0	0	0	297
08:45	0	67	23	1	34	39	38	1	30	70	0	0	0	0	0	0	303
Total	0	257	71	1	122	130	162	1	104	268	0	16	0	0	0	0	1132
*** BREAK ***																	
15:00	0	77	18	3	27	36	12	1	56	108	0	4	0	0	0	0	342
15:15	3	103	27	2	17	24	12	0	33	93	2	3	0	0	0	0	319
15:30	0	104	38	0	24	54	10	0	54	110	0	6	0	0	0	0	400
15:45	0	114	14	1	27	28	10	1	54	123	0	10	0	0	0	0	382
Total	3	398	97	6	95	142	44	2	197	434	2	23	0	0	0	0	1443
16:00	0	107	20	1	30	55	13	0	49	126	0	6	0	0	0	0	407
16:15	0	144	19	1	26	24	14	0	36	127	0	3	0	0	0	0	394
16:30	0	143	23	8	36	36	20	4	36	135	0	11	0	0	0	0	452
16:45	0	154	15	3	35	28	30	0	38	141	0	3	0	0	0	0	447
Total	0	548	77	13	127	143	77	4	159	529	0	23	0	0	0	0	1700
17:00	0	189	22	8	54	43	35	1	38	139	0	13	0	0	0	0	542
17:15	0	167	18	4	59	32	35	1	39	167	0	15	0	0	0	0	537
17:30	0	142	13	3	41	26	31	3	30	130	0	3	0	0	0	0	422
17:45	0	159	16	5	49	21	36	2	27	159	0	3	0	0	0	0	477
Total	0	657	69	20	203	122	137	7	134	595	0	34	0	0	0	0	1978
Grand Total	3	2231	513	44	703	817	557	16	854	2320	2	109	0	0	0	1	8170
Apprch %	0.1	79.9	18.4	1.6	33.6	39	26.6	0.8	26	70.6	0.1	3.3	0	0	0	100	
Total %	0	27.3	6.3	0.5	8.6	10	6.8	0.2	10.5	28.4	0	1.3	0	0	0	0	



MINNESOTA DEPT OF TRANSPORTATION

TRAFFIC DATA COLLECTION - METRO

I-494 at Portland Ave., North Ramps
 Ref.Pt.: 003.848
 JAMAR # T-2638 CAH
 TURN MOVEMENT COUNT

File Name : I-494 at Portland Ave north ramps 2010
 Site Code : 00000000
 Start Date : 10/6/2010
 Page No : 2

Start Time	Portland Ave. Southbound					ramp from WB I-494 Westbound					Portland Ave. Northbound					ramp to WB I-494 Eastbound					Int. Total
	Left	Thru	Right	Peds	App. Total	Left	Thru	Right	Peds	App. Total	Left	Thru	Right	Peds	App. Total	Left	Thru	Right	Peds	App. Total	
Peak Hour Analysis From 06:00 to 08:45 - Peak 1 of 1																					
Peak Hour for Entire Intersection Begins at 07:15																					
07:15	0	52	31	0	83	35	38	22	0	95	30	87	0	0	117	0	0	0	0	0	295
07:30	0	80	34	4	118	24	50	31	2	107	21	97	0	1	119	0	0	0	1	1	345
07:45	0	88	21	0	109	31	23	39	0	93	23	86	0	4	113	0	0	0	0	0	315
08:00	0	62	15	0	77	21	25	39	0	85	22	66	0	1	89	0	0	0	0	0	251
Total Volume	0	282	101	4	387	111	136	131	2	380	96	336	0	6	438	0	0	0	1	1	1206
% App. Total	0	72.9	26.1	1		29.2	35.8	34.5	0.5		21.9	76.7	0	1.4		0	0	0	100		
PHF	.000	.801	.743	.250	.820	.793	.680	.840	.250	.888	.800	.866	.000	.375	.920	.000	.000	.000	.250	.250	.874

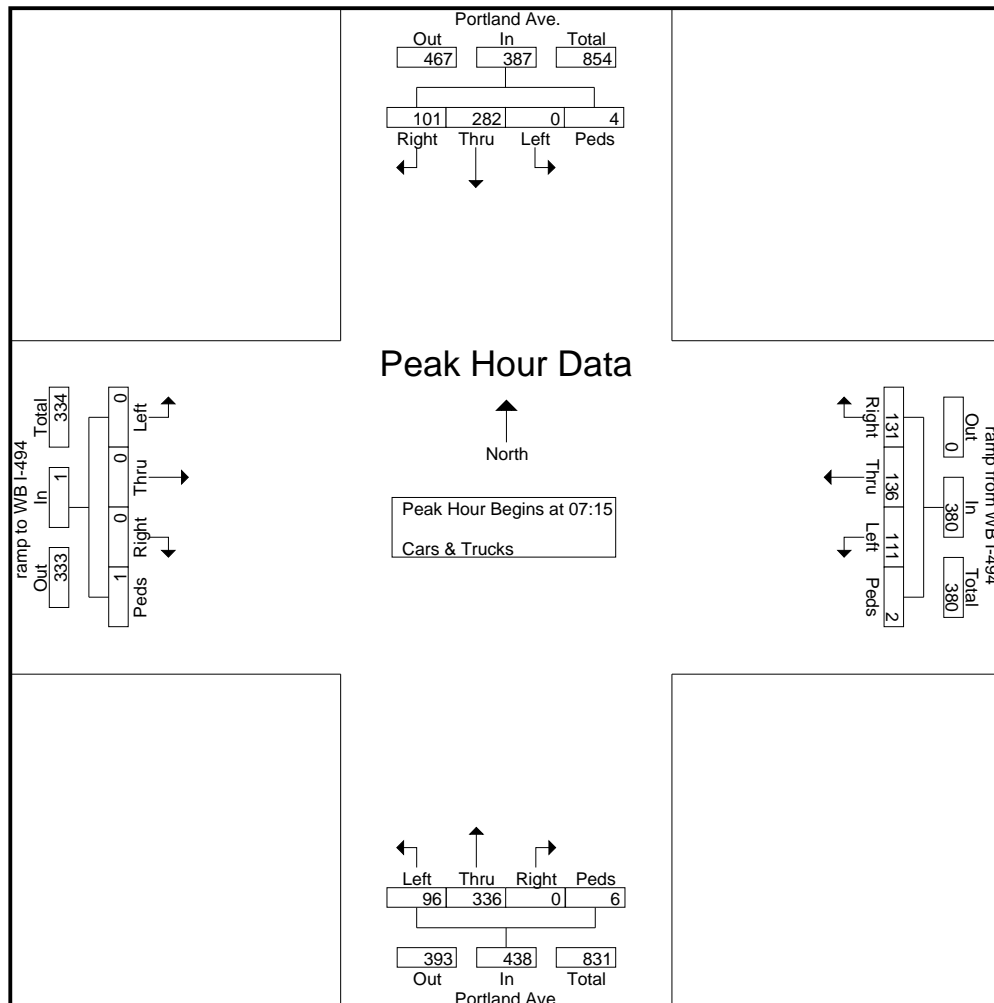



MINNESOTA DEPT OF TRANSPORTATION

TRAFFIC DATA COLLECTION - METRO

I-494 at Portland Ave., North Ramps
 Ref.Pt.: 003.848
 JAMAR # T-2638 CAH
 TURN MOVEMENT COUNT

File Name : I-494 at Portland Ave north ramps 2010
 Site Code : 00000000
 Start Date : 10/6/2010
 Page No : 3

Start Time	Portland Ave. Southbound					ramp from WB I-494 Westbound					Portland Ave. Northbound					ramp to WB I-494 Eastbound					Int. Total
	Left	Thru	Right	Peds	App. Total	Left	Thru	Right	Peds	App. Total	Left	Thru	Right	Peds	App. Total	Left	Thru	Right	Peds	App. Total	
Peak Hour Analysis From 15:00 to 17:45 - Peak 1 of 1																					
Peak Hour for Entire Intersection Begins at 16:30																					
16:30	0	143	23	8	174	36	36	20	4	96	36	135	0	11	182	0	0	0	0	0	452
16:45	0	154	15	3	172	35	28	30	0	93	38	141	0	3	182	0	0	0	0	0	447
17:00	0	189	22	8	219	54	43	35	1	133	38	139	0	13	190	0	0	0	0	0	542
17:15	0	167	18	4	189	59	32	35	1	127	39	167	0	15	221	0	0	0	0	0	537
Total Volume	0	653	78	23	754	184	139	120	6	449	151	582	0	42	775	0	0	0	0	0	1978
% App. Total	0	86.6	10.3	3.1		41	31	26.7	1.3		19.5	75.1	0	5.4		0	0	0	0		
PHF	.000	.864	.848	.719	.861	.780	.808	.857	.375	.844	.968	.871	.000	.700	.877	.000	.000	.000	.000	.000	.912

