



# MINNESOTA DEPT OF TRANSPORTATION

## TRAFFIC DATA COLLECTION - METRO

I-35W at Co Rd E2, east ramps  
 Ref.Pt.: 026.067  
 JAMAR # T2638 CAH  
 TURN MOVEMENT COUNT

File Name : I-35W at Co Rd E2 east ramps 2011  
 Site Code : 00000000  
 Start Date : 8/17/2011  
 Page No : 1

**Groups Printed- Cars & Trucks**

| Start Time    | ramp to I-35W NB Southbound |      |       |      | Co.Rd. E2 Westbound |      |       |      | ramp from I-35W NB Northbound |      |       |      | Co.Rd. E2 Eastbound |      |       |      | Int. Total |
|---------------|-----------------------------|------|-------|------|---------------------|------|-------|------|-------------------------------|------|-------|------|---------------------|------|-------|------|------------|
|               | Left                        | Thru | Right | Peds | Left                | Thru | Right | Peds | Left                          | Thru | Right | Peds | Left                | Thru | Right | Peds |            |
| 06:00         | 0                           | 0    | 0     | 0    | 0                   | 15   | 11    | 0    | 13                            | 0    | 1     | 0    | 23                  | 12   | 0     | 0    | 75         |
| 06:15         | 0                           | 0    | 0     | 0    | 0                   | 15   | 8     | 1    | 19                            | 0    | 1     | 0    | 14                  | 30   | 0     | 0    | 88         |
| 06:30         | 0                           | 0    | 0     | 0    | 0                   | 12   | 13    | 1    | 26                            | 0    | 3     | 0    | 17                  | 26   | 0     | 1    | 99         |
| 06:45         | 0                           | 0    | 0     | 0    | 0                   | 23   | 13    | 0    | 23                            | 0    | 7     | 0    | 14                  | 49   | 0     | 1    | 130        |
| Total         | 0                           | 0    | 0     | 0    | 0                   | 65   | 45    | 2    | 81                            | 0    | 12    | 0    | 68                  | 117  | 0     | 2    | 392        |
| 07:00         | 0                           | 0    | 0     | 0    | 0                   | 37   | 28    | 3    | 14                            | 0    | 3     | 0    | 44                  | 42   | 0     | 1    | 172        |
| 07:15         | 0                           | 0    | 0     | 0    | 0                   | 41   | 16    | 0    | 31                            | 0    | 7     | 0    | 25                  | 52   | 0     | 1    | 173        |
| 07:30         | 0                           | 0    | 0     | 0    | 0                   | 51   | 27    | 1    | 36                            | 0    | 3     | 0    | 30                  | 76   | 0     | 0    | 224        |
| 07:45         | 0                           | 0    | 0     | 0    | 0                   | 49   | 16    | 1    | 37                            | 0    | 16    | 0    | 31                  | 102  | 0     | 1    | 253        |
| Total         | 0                           | 0    | 0     | 0    | 0                   | 178  | 87    | 5    | 118                           | 0    | 29    | 0    | 130                 | 272  | 0     | 3    | 822        |
| 08:00         | 0                           | 0    | 0     | 0    | 0                   | 26   | 17    | 1    | 40                            | 0    | 15    | 0    | 19                  | 69   | 0     | 1    | 188        |
| 08:15         | 0                           | 0    | 0     | 0    | 0                   | 28   | 24    | 1    | 45                            | 0    | 13    | 0    | 25                  | 73   | 0     | 1    | 210        |
| 08:30         | 0                           | 0    | 0     | 0    | 0                   | 26   | 23    | 3    | 37                            | 0    | 7     | 0    | 33                  | 43   | 0     | 0    | 172        |
| 08:45         | 0                           | 0    | 0     | 0    | 0                   | 29   | 17    | 2    | 40                            | 1    | 16    | 0    | 30                  | 68   | 0     | 0    | 203        |
| Total         | 0                           | 0    | 0     | 0    | 0                   | 109  | 81    | 7    | 162                           | 1    | 51    | 0    | 107                 | 253  | 0     | 2    | 773        |
| *** BREAK *** |                             |      |       |      |                     |      |       |      |                               |      |       |      |                     |      |       |      |            |
| 15:00         | 0                           | 0    | 0     | 0    | 0                   | 48   | 24    | 3    | 48                            | 1    | 14    | 0    | 50                  | 60   | 0     | 0    | 248        |
| 15:15         | 0                           | 0    | 0     | 0    | 0                   | 50   | 23    | 3    | 28                            | 1    | 12    | 0    | 16                  | 37   | 1     | 0    | 171        |
| 15:30         | 0                           | 0    | 0     | 0    | 0                   | 64   | 62    | 3    | 29                            | 0    | 10    | 0    | 37                  | 49   | 0     | 0    | 254        |
| 15:45         | 0                           | 0    | 0     | 0    | 0                   | 88   | 68    | 0    | 33                            | 0    | 10    | 0    | 29                  | 72   | 0     | 1    | 301        |
| Total         | 0                           | 0    | 0     | 0    | 0                   | 250  | 177   | 9    | 138                           | 2    | 46    | 0    | 132                 | 218  | 1     | 1    | 974        |
| 16:00         | 0                           | 0    | 0     | 0    | 0                   | 97   | 65    | 0    | 24                            | 0    | 6     | 0    | 37                  | 63   | 0     | 1    | 293        |
| 16:15         | 0                           | 0    | 0     | 0    | 0                   | 96   | 65    | 3    | 21                            | 0    | 7     | 0    | 29                  | 75   | 0     | 0    | 296        |
| 16:30         | 0                           | 0    | 0     | 0    | 0                   | 106  | 94    | 2    | 18                            | 0    | 9     | 0    | 37                  | 82   | 0     | 2    | 350        |
| 16:45         | 0                           | 0    | 0     | 0    | 0                   | 111  | 94    | 0    | 21                            | 1    | 9     | 0    | 27                  | 87   | 0     | 1    | 351        |
| Total         | 0                           | 0    | 0     | 0    | 0                   | 410  | 318   | 5    | 84                            | 1    | 31    | 0    | 130                 | 307  | 0     | 4    | 1290       |
| 17:00         | 0                           | 0    | 0     | 0    | 0                   | 98   | 111   | 3    | 20                            | 0    | 15    | 1    | 47                  | 96   | 0     | 2    | 393        |
| 17:15         | 0                           | 0    | 0     | 0    | 0                   | 102  | 97    | 2    | 28                            | 0    | 11    | 0    | 30                  | 114  | 0     | 1    | 385        |
| 17:30         | 0                           | 0    | 0     | 0    | 0                   | 112  | 78    | 2    | 30                            | 1    | 26    | 0    | 35                  | 79   | 0     | 0    | 363        |
| 17:45         | 0                           | 0    | 0     | 0    | 0                   | 75   | 37    | 3    | 39                            | 2    | 17    | 0    | 22                  | 68   | 0     | 1    | 264        |
| Total         | 0                           | 0    | 0     | 0    | 0                   | 387  | 323   | 10   | 117                           | 3    | 69    | 1    | 134                 | 357  | 0     | 4    | 1405       |
| Grand Total   | 0                           | 0    | 0     | 0    | 0                   | 1399 | 1031  | 38   | 700                           | 7    | 238   | 1    | 701                 | 1524 | 1     | 16   | 5656       |
| Apprch %      | 0                           | 0    | 0     | 0    | 0                   | 56.7 | 41.8  | 1.5  | 74                            | 0.7  | 25.2  | 0.1  | 31.3                | 68   | 0     | 0.7  |            |
| Total %       | 0                           | 0    | 0     | 0    | 0                   | 24.7 | 18.2  | 0.7  | 12.4                          | 0.1  | 4.2   | 0    | 12.4                | 26.9 | 0     | 0.3  |            |



# MINNESOTA DEPT OF TRANSPORTATION

## TRAFFIC DATA COLLECTION - METRO

I-35W at Co Rd E2, east ramps  
 Ref.Pt.: 026.067  
 JAMAR # T2638 CAH  
 TURN MOVEMENT COUNT

File Name : I-35W at Co Rd E2 east ramps 2011  
 Site Code : 00000000  
 Start Date : 8/17/2011  
 Page No : 2

| Start Time   | ramp to I-35W NB Southbound |      |       |      |            | Co.Rd. E2 Westbound |      |       |       |            | ramp from I-35W NB Northbound |      |       |      |            | Co.Rd. E2 Eastbound |      |       |      |            | Int. Total |
|--|-----------------------------|------|-------|------|------------|---------------------|------|-------|-------|------------|-------------------------------|------|-------|------|------------|---------------------|------|-------|------|------------|------------|
|  | Left                        | Thru | Right | Peds | App. Total | Left                | Thru | Right | Peds  | App. Total | Left                          | Thru | Right | Peds | App. Total | Left                | Thru | Right | Peds | App. Total |            |
| Peak Hour Analysis From 06:00 to 08:45 - Peak 1 of 1 |                             |      |       |      |            |                     |      |       |       |            |                               |      |       |      |            |                     |      |       |      |            |            |
| Peak Hour for Entire Intersection Begins at 07:30    |                             |      |       |      |            |                     |      |       |       |            |                               |      |       |      |            |                     |      |       |      |            |            |
| 07:30  | 0                           | 0    | 0     | 0    | 0          | 0                   | 51   | 27    | 1     | 79         | 36                            | 0    | 3     | 0    | 39         | 30                  | 76   | 0     | 0    | 106        | 224        |
| 07:45  | 0                           | 0    | 0     | 0    | 0          | 0                   | 49   | 16    | 1     | 66         | 37                            | 0    | 16    | 0    | 53         | 31                  | 102  | 0     | 1    | 134        | 253        |
| 08:00  | 0                           | 0    | 0     | 0    | 0          | 0                   | 26   | 17    | 1     | 44         | 40                            | 0    | 15    | 0    | 55         | 19                  | 69   | 0     | 1    | 89         | 188        |
| 08:15  | 0                           | 0    | 0     | 0    | 0          | 0                   | 28   | 24    | 1     | 53         | 45                            | 0    | 13    | 0    | 58         | 25                  | 73   | 0     | 1    | 99         | 210        |
| Total Volume   | 0                           | 0    | 0     | 0    | 0          | 0                   | 154  | 84    | 4     | 242        | 158                           | 0    | 47    | 0    | 205        | 105                 | 320  | 0     | 3    | 428        | 875        |
| % App. Total   | 0                           | 0    | 0     | 0    | 0          | 0                   | 63.6 | 34.7  | 1.7   |            | 77.1                          | 0    | 22.9  | 0    |            | 24.5                | 74.8 | 0     | 0.7  |            |            |
| PHF  | .000                        | .000 | .000  | .000 | .000       | .000                | .755 | .778  | 1.000 |            | .878                          | .000 | .734  | .000 | .884       | .847                | .784 | .000  | .750 | .799       | .865       |

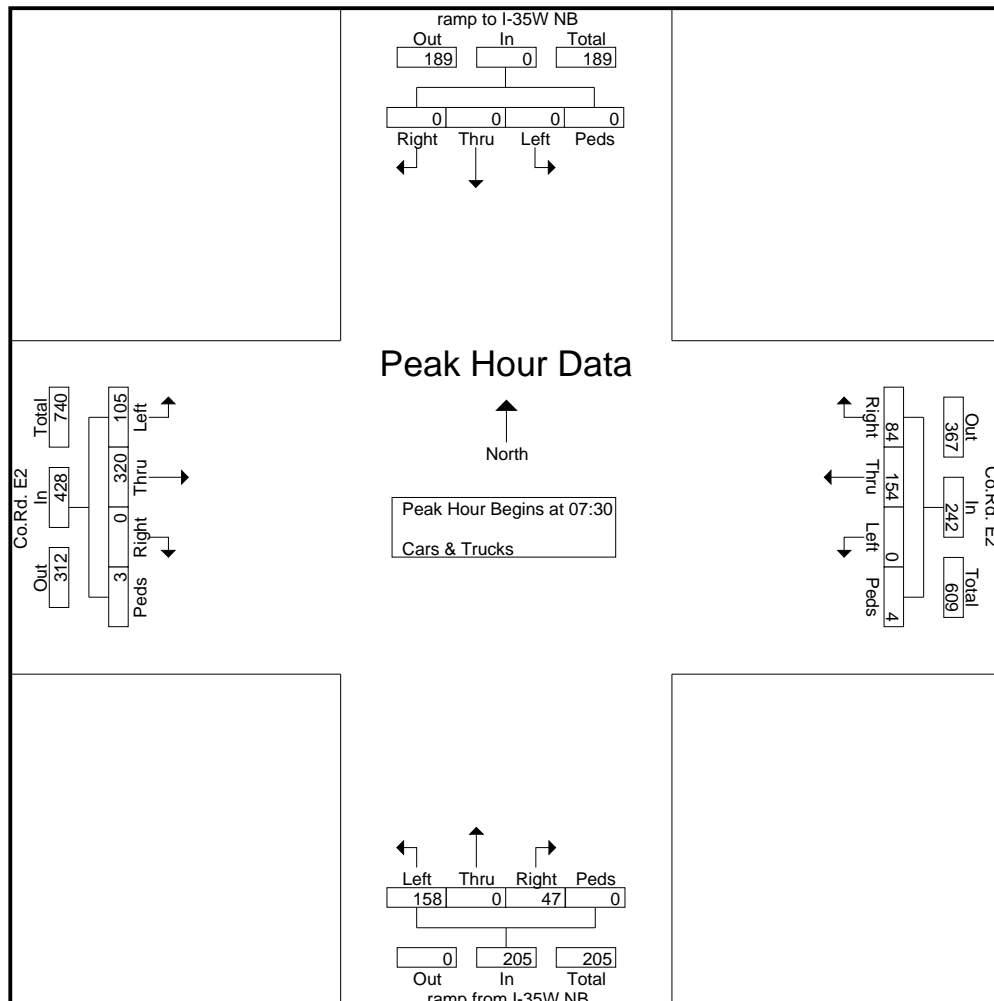



# MINNESOTA DEPT OF TRANSPORTATION

## TRAFFIC DATA COLLECTION - METRO

I-35W at Co Rd E2, east ramps  
 Ref.Pt.: 026.067  
 JAMAR # T2638 CAH  
 TURN MOVEMENT COUNT

File Name : I-35W at Co Rd E2 east ramps 2011  
 Site Code : 00000000  
 Start Date : 8/17/2011  
 Page No : 3

| Start Time   | ramp to I-35W NB Southbound |      |       |      |            | Co.Rd. E2 Westbound |      |       |      |            | ramp from I-35W NB Northbound |      |       |      |            | Co.Rd. E2 Eastbound |      |       |      |            | Int. Total |
|--|-----------------------------|------|-------|------|------------|---------------------|------|-------|------|------------|-------------------------------|------|-------|------|------------|---------------------|------|-------|------|------------|------------|
|  | Left                        | Thru | Right | Peds | App. Total | Left                | Thru | Right | Peds | App. Total | Left                          | Thru | Right | Peds | App. Total | Left                | Thru | Right | Peds | App. Total |            |
| Peak Hour Analysis From 15:00 to 17:45 - Peak 1 of 1 |                             |      |       |      |            |                     |      |       |      |            |                               |      |       |      |            |                     |      |       |      |            |            |
| Peak Hour for Entire Intersection Begins at 16:45    |                             |      |       |      |            |                     |      |       |      |            |                               |      |       |      |            |                     |      |       |      |            |            |
| 16:45  | 0                           | 0    | 0     | 0    | 0          | 0                   | 111  | 94    | 0    | 205        | 21                            | 1    | 9     | 0    | 31         | 27                  | 87   | 0     | 1    | 115        | 351        |
| 17:00  | 0                           | 0    | 0     | 0    | 0          | 0                   | 98   | 111   | 3    | 212        | 20                            | 0    | 15    | 1    | 36         | 47                  | 96   | 0     | 2    | 145        | 393        |
| 17:15  | 0                           | 0    | 0     | 0    | 0          | 0                   | 102  | 97    | 2    | 201        | 28                            | 0    | 11    | 0    | 39         | 30                  | 114  | 0     | 1    | 145        | 385        |
| 17:30  | 0                           | 0    | 0     | 0    | 0          | 0                   | 112  | 78    | 2    | 192        | 30                            | 1    | 26    | 0    | 57         | 35                  | 79   | 0     | 0    | 114        | 363        |
| Total Volume   | 0                           | 0    | 0     | 0    | 0          | 0                   | 423  | 380   | 7    | 810        | 99                            | 2    | 61    | 1    | 163        | 139                 | 376  | 0     | 4    | 519        | 1492       |
| % App. Total   | 0                           | 0    | 0     | 0    | 0          | 0                   | 52.2 | 46.9  | 0.9  |            | 60.7                          | 1.2  | 37.4  | 0.6  |            | 26.8                | 72.4 | 0     | 0.8  |            |            |
| PHF  | .000                        | .000 | .000  | .000 | .000       | .000                | .944 | .856  | .583 | .955       | .825                          | .500 | .587  | .250 | .715       | .739                | .825 | .000  | .500 | .895       | .949       |

