



MINNESOTA DEPT OF TRANSPORTATION

TRAFFIC DATA COLLECTION - METRO

Co.Rd. E2 at Cleveland Ave N.
 Ref.Pt.: 026.067 I-35W
 JAMAR #T2638 CAH
 TURN MOVEMENT COUNT

File Name : CoRd E2 at Cleveland Ave N 2011
 Site Code : 00000000
 Start Date : 8/18/2011
 Page No : 1

Groups Printed- Cars & Trucks

Start Time	CLEVELAND AVE N Southbound				Co.Rd. E2 Westbound				CLEVELAND AVE N Northbound				Co.Rd. E2 Eastbound				Int. Total
	Left	Thru	Right	Peds	Left	Thru	Right	Peds	Left	Thru	Right	Peds	Left	Thru	Right	Peds	
06:00	0	0	0	0	0	19	0	0	9	0	0	0	0	11	7	0	46
06:15	0	0	0	0	0	15	0	1	5	0	0	0	0	16	10	0	47
06:30	0	0	0	0	4	20	0	0	10	0	0	0	0	16	12	1	63
06:45	0	0	0	0	5	34	0	0	22	0	0	0	0	25	15	0	101
Total	0	0	0	0	9	88	0	1	46	0	0	0	0	68	44	1	257
07:00	0	0	0	0	6	48	0	1	12	0	2	0	0	27	15	1	112
07:15	0	0	0	0	5	39	0	1	16	0	1	1	0	45	29	0	137
07:30	0	0	0	0	1	51	0	0	19	0	0	0	0	42	45	1	159
07:45	0	0	0	0	14	49	0	0	11	0	1	0	0	41	46	0	162
Total	0	0	0	0	26	187	0	2	58	0	4	1	0	155	135	2	570
08:00	0	0	0	0	1	40	0	0	15	0	0	2	0	49	27	0	134
08:15	0	0	0	0	6	44	0	0	10	0	2	0	0	42	36	1	141
08:30	0	0	0	0	5	30	0	1	15	0	2	1	0	41	14	0	109
08:45	0	0	0	0	1	40	0	1	16	0	0	0	0	46	29	1	134
Total	0	0	0	0	13	154	0	2	56	0	4	3	0	178	106	2	518
*** BREAK ***																	
15:00	0	0	0	0	3	44	0	1	22	0	2	0	0	44	11	0	127
15:15	0	0	0	0	0	43	0	0	32	0	8	0	0	42	11	0	136
15:30	0	0	0	0	3	37	0	1	60	0	2	1	0	50	15	0	169
15:45	0	0	0	0	0	59	0	0	74	0	12	0	0	58	10	1	214
Total	0	0	0	0	6	183	0	2	188	0	24	1	0	194	47	1	646
16:00	0	0	0	0	3	76	0	1	75	0	21	0	0	54	19	1	250
16:15	0	0	0	0	3	83	0	0	79	0	9	0	0	65	25	1	265
16:30	0	0	0	0	1	100	0	1	109	0	14	0	0	70	19	2	316
16:45	0	0	0	0	0	96	0	1	102	0	15	1	2	85	17	1	320
Total	0	0	0	0	7	355	0	3	365	0	59	1	2	274	80	5	1151
17:00	0	0	0	0	3	90	0	0	94	0	17	0	0	93	20	2	319
17:15	0	0	0	0	1	85	0	0	85	0	25	0	0	89	15	1	301
17:30	0	0	0	0	1	78	0	0	78	1	24	0	0	84	20	1	287
17:45	0	0	0	0	1	66	0	0	85	0	23	0	0	67	19	3	264
Total	0	0	0	0	6	319	0	0	342	1	89	0	0	333	74	7	1171
Grand Total	0	0	0	0	67	1286	0	10	1055	1	180	6	2	1202	486	18	4313
Apprch %	0	0	0	0	4.9	94.4	0	0.7	84.9	0.1	14.5	0.5	0.1	70.4	28.5	1.1	
Total %	0	0	0	0	1.6	29.8	0	0.2	24.5	0	4.2	0.1	0	27.9	11.3	0.4	



MINNESOTA DEPT OF TRANSPORTATION

TRAFFIC DATA COLLECTION - METRO

Co.Rd. E2 at Cleveland Ave N.
 Ref.Pt.: 026.067 I-35W
 JAMAR #T2638 CAH
 TURN MOVEMENT COUNT

File Name : CoRd E2 at Cleveland Ave N 2011
 Site Code : 00000000
 Start Date : 8/18/2011
 Page No : 2

Start Time	CLEVELAND AVE N Southbound					Co.Rd. E2 Westbound					CLEVELAND AVE N Northbound					Co.Rd. E2 Eastbound					Int. Total
	Left	Thru	Right	Peds	App. Total	Left	Thru	Right	Peds	App. Total	Left	Thru	Right	Peds	App. Total	Left	Thru	Right	Peds	App. Total	
Peak Hour Analysis From 06:00 to 08:45 - Peak 1 of 1																					
Peak Hour for Entire Intersection Begins at 07:30																					
07:30	0	0	0	0	0	1	51	0	0	52	19	0	0	0	19	0	42	45	1	88	159
07:45	0	0	0	0	0	14	49	0	0	63	11	0	1	0	12	0	41	46	0	87	162
08:00	0	0	0	0	0	1	40	0	0	41	15	0	0	2	17	0	49	27	0	76	134
08:15	0	0	0	0	0	6	44	0	0	50	10	0	2	0	12	0	42	36	1	79	141
Total Volume	0	0	0	0	0	22	184	0	0	206	55	0	3	2	60	0	174	154	2	330	596
% App. Total	0	0	0	0	0	10.7	89.3	0	0		91.7	0	5	3.3		0	52.7	46.7	0.6		
PHF	.000	.000	.000	.000	.000	.393	.902	.000	.000	.817	.724	.000	.375	.250	.789	.000	.888	.837	.500	.938	.920

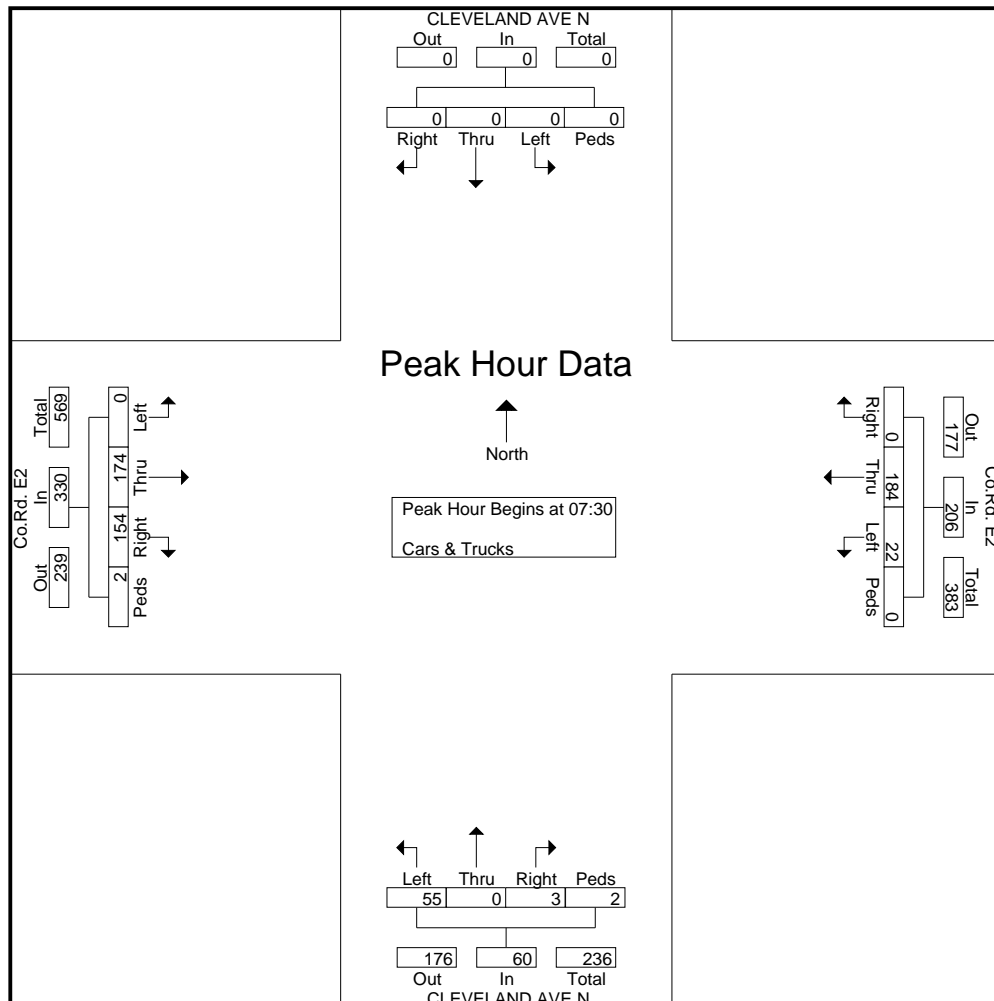



MINNESOTA DEPT OF TRANSPORTATION

TRAFFIC DATA COLLECTION - METRO

Co.Rd. E2 at Cleveland Ave N.
 Ref.Pt.: 026.067 I-35W
 JAMAR #T2638 CAH
 TURN MOVEMENT COUNT

File Name : CoRd E2 at Cleveland Ave N 2011
 Site Code : 00000000
 Start Date : 8/18/2011
 Page No : 3

Start Time	CLEVELAND AVE N Southbound					Co.Rd. E2 Westbound					CLEVELAND AVE N Northbound					Co.Rd. E2 Eastbound					Int. Total
	Left	Thru	Right	Peds	App. Total	Left	Thru	Right	Peds	App. Total	Left	Thru	Right	Peds	App. Total	Left	Thru	Right	Peds	App. Total	

Peak Hour Analysis From 15:00 to 17:45 - Peak 1 of 1
 Peak Hour for Entire Intersection Begins at 16:30

16:30	0	0	0	0	0	1	100	0	1	102	109	0	14	0	123	0	70	19	2	91	316
16:45	0	0	0	0	0	0	96	0	1	97	102	0	15	1	118	2	85	17	1	105	320
17:00	0	0	0	0	0	3	90	0	0	93	94	0	17	0	111	0	93	20	2	115	319
17:15	0	0	0	0	0	1	85	0	0	86	85	0	25	0	110	0	89	15	1	105	301
Total Volume	0	0	0	0	0	5	371	0	2	378	390	0	71	1	462	2	337	71	6	416	1256
% App. Total	0	0	0	0	0	1.3	98.1	0	0.5		84.4	0	15.4	0.2		0.5	81	17.1	1.4		
PHF	.000	.000	.000	.000	.000	.417	.928	.000	.500	.926	.894	.000	.710	.250	.939	.250	.906	.888	.750	.904	.981

