



MINNESOTA DEPT OF TRANSPORTATION

TRAFFIC DATA COLLECTION - METRO

Location: I-35W SB RAMP AT W 76TH ST.
 Ref.Pt.: 008.991
 JAMAR# 632 DR
 TURN MOVEMENT COUNT

File Name : Not Named 1
 Site Code : 00000000
 Start Date : 2/12/2008
 Page No : 1

Groups Printed- Unshifted

Start Time	35W S EXIT Southbound				W 76TH ST Westbound				35W S EXIT Northbound				W 76TH ST Eastbound				Int. Total
	Left	Thru	Right	Peds	Left	Thru	Right	Peds	Left	Thru	Right	Peds	Left	Thru	Right	Peds	
06:00	8	0	14	0	0	27	0	0	0	0	0	0	0	23	0	0	72
06:15	13	0	20	0	0	38	0	1	0	0	0	0	0	31	0	0	103
06:30	23	0	19	0	0	75	0	0	0	0	0	0	0	59	0	0	176
06:45	36	0	51	0	0	116	0	0	0	0	0	0	0	79	0	1	283
Total	80	0	104	0	0	256	0	1	0	0	0	0	0	192	0	1	634
07:00	20	0	51	0	0	158	0	2	0	0	0	0	0	85	0	1	317
07:15	37	0	92	0	0	192	0	0	0	0	0	0	0	120	0	0	441
07:30	31	0	114	0	0	276	0	0	0	0	0	0	0	125	0	1	547
07:45	71	0	137	0	0	374	0	1	0	0	0	0	0	217	0	1	801
Total	159	0	394	0	0	1000	0	3	0	0	0	0	0	547	0	3	2106
08:00	66	0	127	0	0	287	0	1	0	0	0	0	0	136	0	0	617
08:15	66	0	134	0	0	204	0	0	0	0	0	0	0	112	0	1	517
08:30	58	0	119	0	0	187	0	0	0	0	0	0	0	100	0	0	464
08:45	52	0	97	0	0	182	0	0	0	0	0	0	0	84	0	0	415
Total	242	0	477	0	0	860	0	1	0	0	0	0	0	432	0	1	2013
*** BREAK ***																	
15:00	36	0	34	3	0	112	0	0	0	0	0	0	0	168	0	0	353
15:15	35	0	35	1	0	99	0	0	0	0	0	0	0	185	0	0	355
15:30	40	0	40	2	0	121	0	0	0	0	0	0	0	210	0	0	413
15:45	45	0	25	1	0	149	0	0	0	0	0	0	0	214	0	0	434
Total	156	0	134	7	0	481	0	0	0	0	0	0	0	777	0	0	1555
16:00	36	0	31	1	0	130	0	0	0	0	0	0	0	290	0	0	488
16:15	37	0	50	1	0	131	0	0	0	0	0	0	0	307	0	0	526
16:30	39	0	47	0	0	144	0	0	0	0	0	0	0	388	0	0	618
16:45	49	0	42	0	0	195	0	0	0	0	0	0	0	419	0	0	705
Total	161	0	170	2	0	600	0	0	0	0	0	0	0	1404	0	0	2337
17:00	44	0	42	0	0	270	0	0	0	0	0	0	0	451	0	0	807
17:15	55	0	39	0	0	272	0	0	0	0	0	0	0	525	0	0	891
17:30	45	0	48	0	0	285	0	0	0	0	0	0	0	427	0	0	805
17:45	33	0	49	0	0	232	0	0	0	0	0	0	0	340	0	0	654
Total	177	0	178	0	0	1059	0	0	0	0	0	0	0	1743	0	0	3157
Grand Total	975	0	1457	9	0	4256	0	5	0	0	0	0	0	5095	0	5	11802
Apprch %	39.9	0	59.7	0.4	0	99.9	0	0.1	0	0	0	0	0	99.9	0	0.1	
Total %	8.3	0	12.3	0.1	0	36.1	0	0	0	0	0	0	0	43.2	0	0	



MINNESOTA DEPT OF TRANSPORTATION

TRAFFIC DATA COLLECTION - METRO

Location: I-35W SB RAMP AT W 76TH ST.

Ref.Pt.: 008.991

JAMAR# 632 DR

TURN MOVEMENT COUNT

File Name : Not Named 1

Site Code : 00000000

Start Date : 2/12/2008

Page No : 2

Start Time	35W S EXIT Southbound					W 76TH ST Westbound					35W S EXIT Northbound					W 76TH ST Eastbound					Int. Total
	Left	Thru	Right	Peds	App. Total	Left	Thru	Right	Peds	App. Total	Left	Thru	Right	Peds	App. Total	Left	Thru	Right	Peds	App. Total	
Peak Hour Analysis From 06:00 to 08:45 - Peak 1 of 1																					
Peak Hour for Entire Intersection Begins at 07:30																					
07:30	31	0	114	0	145	0	276	0	0	276	0	0	0	0	0	0	125	0	1	126	547
07:45	71	0	137	0	208	0	374	0	1	375	0	0	0	0	0	0	217	0	1	218	801
08:00	66	0	127	0	193	0	287	0	1	288	0	0	0	0	0	0	136	0	0	136	617
08:15	66	0	134	0	200	0	204	0	0	204	0	0	0	0	0	0	112	0	1	113	517
Total Volume	234	0	512	0	746	0	1141	0	2	1143	0	0	0	0	0	0	590	0	3	593	2482
% App. Total	31.4	0	68.6	0		0	99.8	0	0.2		0	0	0	0		0	99.5	0	0.5		
PHF	.824	.000	.934	.000	.897	.000	.763	.000	.500	.762	.000	.000	.000	.000	.000	.000	.680	.000	.750	.680	.775

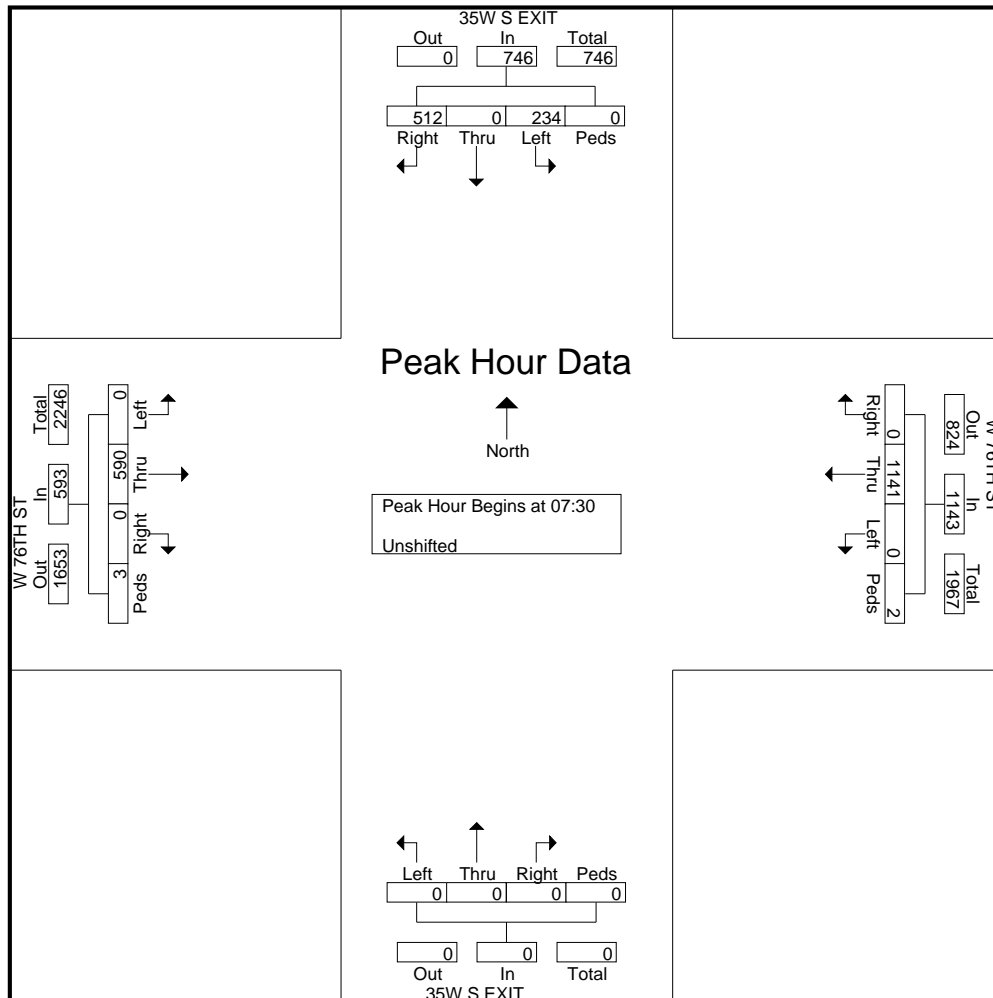



MINNESOTA DEPT OF TRANSPORTATION

TRAFFIC DATA COLLECTION - METRO

Location: I-35W SB RAMP AT W 76TH ST.

Ref.Pt.: 008.991

JAMAR# 632 DR

TURN MOVEMENT COUNT

File Name : Not Named 1

Site Code : 00000000

Start Date : 2/12/2008

Page No : 3

Start Time	35W S EXIT Southbound					W 76TH ST Westbound					35W S EXIT Northbound					W 76TH ST Eastbound					Int. Total
	Left	Thru	Right	Peds	App. Total	Left	Thru	Right	Peds	App. Total	Left	Thru	Right	Peds	App. Total	Left	Thru	Right	Peds	App. Total	
Peak Hour Analysis From 15:00 to 17:45 - Peak 1 of 1																					
Peak Hour for Entire Intersection Begins at 16:45																					
16:45	49	0	42	0	91	0	195	0	0	195	0	0	0	0	0	0	419	0	0	419	705
17:00	44	0	42	0	86	0	270	0	0	270	0	0	0	0	0	0	451	0	0	451	807
17:15	55	0	39	0	94	0	272	0	0	272	0	0	0	0	0	0	525	0	0	525	891
17:30	45	0	48	0	93	0	285	0	0	285	0	0	0	0	0	0	427	0	0	427	805
Total Volume	193	0	171	0	364	0	1022	0	0	1022	0	0	0	0	0	0	1822	0	0	1822	3208
% App. Total	53	0	47	0		0	100	0	0		0	0	0	0		0	100	0	0		
PHF	.877	.000	.891	.000	.968	.000	.896	.000	.000	.896	.000	.000	.000	.000	.000	.000	.868	.000	.000	.868	.900

