



MINNESOTA DEPT OF TRANSPORTATION

TRAFFIC DATA COLLECTION - METRO

Little Canada Rd at Country Dr.
 Ref.Pt.: (W of W ramps of I-35E)
 JAMAR # 631 RE
 TURN MOVEMENT COUNT

File Name : Little Canada Rd at Country Dr 2008
 Site Code : 00000000
 Start Date : 12/3/2008
 Page No : 1

Groups Printed- Cars & Trucks

| Start Time | Country Dr (Frontage Rd) Southbound | | | | Little Canada Rd. Westbound | | | | Gas Station entrance Northbound | | | | Little Canada Rd. Eastbound | | | | Int. Total |
|---------------|----------------------------------------|------|-------|------|--------------------------------|------|-------|------|------------------------------------|------|-------|------|--------------------------------|------|-------|------|------------|
| | Left | Thru | Right | Peds | Left | Thru | Right | Peds | Left | Thru | Right | Peds | Left | Thru | Right | Peds | |
| 06:00 | 23 | 0 | 3 | 0 | 0 | 38 | 19 | 1 | 1 | 0 | 0 | 0 | 1 | 62 | 2 | 0 | 150 |
| 06:15 | 12 | 0 | 1 | 0 | 1 | 38 | 27 | 0 | 2 | 0 | 3 | 0 | 3 | 46 | 5 | 0 | 138 |
| 06:30 | 18 | 1 | 2 | 0 | 1 | 68 | 40 | 0 | 2 | 0 | 1 | 0 | 2 | 74 | 1 | 0 | 210 |
| 06:45 | 24 | 1 | 3 | 0 | 0 | 88 | 62 | 0 | 1 | 0 | 2 | 0 | 3 | 67 | 2 | 0 | 253 |
| Total | 77 | 2 | 9 | 0 | 2 | 232 | 148 | 1 | 6 | 0 | 6 | 0 | 9 | 249 | 10 | 0 | 751 |
| 07:00 | 33 | 0 | 3 | 0 | 0 | 136 | 43 | 0 | 0 | 0 | 1 | 0 | 0 | 69 | 2 | 0 | 287 |
| 07:15 | 37 | 0 | 6 | 0 | 2 | 205 | 73 | 0 | 1 | 0 | 2 | 0 | 10 | 79 | 3 | 0 | 418 |
| 07:30 | 26 | 0 | 10 | 0 | 0 | 265 | 77 | 0 | 0 | 0 | 2 | 0 | 0 | 85 | 2 | 0 | 467 |
| 07:45 | 24 | 0 | 8 | 0 | 4 | 269 | 120 | 0 | 1 | 0 | 5 | 0 | 2 | 86 | 1 | 0 | 520 |
| Total | 120 | 0 | 27 | 0 | 6 | 875 | 313 | 0 | 2 | 0 | 10 | 0 | 12 | 319 | 8 | 0 | 1692 |
| 08:00 | 28 | 0 | 8 | 0 | 0 | 221 | 93 | 0 | 0 | 0 | 1 | 0 | 5 | 93 | 1 | 0 | 450 |
| 08:15 | 27 | 1 | 9 | 0 | 1 | 170 | 66 | 0 | 1 | 0 | 2 | 0 | 1 | 99 | 1 | 0 | 378 |
| 08:30 | 32 | 0 | 2 | 0 | 3 | 133 | 48 | 1 | 1 | 1 | 3 | 0 | 3 | 87 | 2 | 0 | 316 |
| 08:45 | 29 | 1 | 6 | 0 | 1 | 112 | 39 | 0 | 1 | 0 | 1 | 0 | 4 | 86 | 1 | 0 | 281 |
| Total | 116 | 2 | 25 | 0 | 5 | 636 | 246 | 1 | 3 | 1 | 7 | 0 | 13 | 365 | 5 | 0 | 1425 |
| *** BREAK *** | | | | | | | | | | | | | | | | | |
| 11:00 | 37 | 0 | 7 | 0 | 0 | 96 | 33 | 0 | 0 | 0 | 0 | 0 | 1 | 79 | 0 | 0 | 253 |
| 11:15 | 34 | 0 | 9 | 0 | 1 | 83 | 26 | 0 | 0 | 1 | 0 | 0 | 0 | 97 | 2 | 0 | 253 |
| 11:30 | 32 | 1 | 10 | 0 | 0 | 109 | 37 | 0 | 1 | 0 | 1 | 0 | 5 | 92 | 1 | 0 | 289 |
| 11:45 | 32 | 1 | 6 | 0 | 0 | 89 | 37 | 0 | 0 | 2 | 2 | 0 | 7 | 86 | 5 | 0 | 267 |
| Total | 135 | 2 | 32 | 0 | 1 | 377 | 133 | 0 | 1 | 3 | 3 | 0 | 13 | 354 | 8 | 0 | 1062 |
| 12:00 | 47 | 2 | 7 | 0 | 2 | 120 | 31 | 0 | 3 | 1 | 3 | 0 | 6 | 86 | 3 | 0 | 311 |
| 12:15 | 28 | 0 | 7 | 0 | 0 | 95 | 53 | 1 | 1 | 2 | 3 | 0 | 7 | 95 | 2 | 0 | 294 |
| 12:30 | 37 | 0 | 7 | 0 | 1 | 104 | 34 | 0 | 3 | 0 | 1 | 0 | 3 | 131 | 5 | 0 | 326 |
| 12:45 | 44 | 1 | 9 | 0 | 3 | 111 | 45 | 0 | 1 | 1 | 4 | 0 | 8 | 104 | 5 | 0 | 336 |
| Total | 156 | 3 | 30 | 0 | 6 | 430 | 163 | 1 | 8 | 4 | 11 | 0 | 24 | 416 | 15 | 0 | 1267 |
| *** BREAK *** | | | | | | | | | | | | | | | | | |
| 14:45 | 43 | 0 | 4 | 0 | 0 | 127 | 27 | 0 | 0 | 1 | 5 | 0 | 10 | 134 | 4 | 0 | 355 |
| Total | 43 | 0 | 4 | 0 | 0 | 127 | 27 | 0 | 0 | 1 | 5 | 0 | 10 | 134 | 4 | 0 | 355 |
| 15:00 | 41 | 0 | 9 | 0 | 1 | 132 | 46 | 0 | 1 | 0 | 2 | 0 | 6 | 144 | 4 | 1 | 387 |
| 15:15 | 42 | 0 | 10 | 0 | 0 | 140 | 34 | 0 | 1 | 0 | 1 | 0 | 7 | 146 | 0 | 0 | 381 |
| 15:30 | 54 | 1 | 9 | 0 | 0 | 121 | 35 | 0 | 0 | 0 | 1 | 0 | 2 | 166 | 0 | 1 | 390 |
| 15:45 | 40 | 0 | 7 | 0 | 1 | 142 | 38 | 0 | 2 | 0 | 1 | 0 | 10 | 143 | 2 | 0 | 386 |
| Total | 177 | 1 | 35 | 0 | 2 | 535 | 153 | 0 | 4 | 0 | 5 | 0 | 25 | 599 | 6 | 2 | 1544 |
| 16:00 | 81 | 0 | 8 | 0 | 0 | 166 | 58 | 0 | 0 | 0 | 0 | 0 | 5 | 162 | 0 | 0 | 480 |
| 16:15 | 58 | 0 | 5 | 0 | 0 | 164 | 38 | 0 | 0 | 0 | 0 | 0 | 5 | 167 | 0 | 0 | 437 |
| 16:30 | 86 | 2 | 8 | 0 | 4 | 117 | 40 | 0 | 0 | 0 | 3 | 0 | 8 | 170 | 4 | 0 | 442 |
| 16:45 | 46 | 1 | 12 | 0 | 2 | 141 | 41 | 0 | 1 | 1 | 8 | 0 | 4 | 182 | 2 | 0 | 441 |
| Total | 271 | 3 | 33 | 0 | 6 | 588 | 177 | 0 | 1 | 1 | 11 | 0 | 22 | 681 | 6 | 0 | 1800 |
| 17:00 | 76 | 0 | 6 | 0 | 0 | 122 | 38 | 0 | 3 | 0 | 2 | 0 | 7 | 183 | 3 | 0 | 440 |
| 17:15 | 44 | 1 | 5 | 0 | 1 | 139 | 42 | 0 | 1 | 0 | 2 | 0 | 4 | 186 | 3 | 0 | 428 |
| 17:30 | 41 | 0 | 4 | 0 | 1 | 141 | 47 | 0 | 0 | 1 | 3 | 0 | 5 | 172 | 1 | 0 | 416 |
| 17:45 | 42 | 0 | 3 | 0 | 1 | 145 | 31 | 1 | 0 | 0 | 2 | 0 | 9 | 148 | 4 | 0 | 386 |
| Total | 203 | 1 | 18 | 0 | 3 | 547 | 158 | 1 | 4 | 1 | 9 | 0 | 25 | 689 | 11 | 0 | 1670 |
| Grand Total | 1298 | 14 | 213 | 0 | 31 | 4347 | 1518 | 4 | 29 | 11 | 67 | 0 | 153 | 3806 | 73 | 2 | 11566 |
| Apprch % | 85.1 | 0.9 | 14 | 0 | 0.5 | 73.7 | 25.7 | 0.1 | 27.1 | 10.3 | 62.6 | 0 | 3.8 | 94.3 | 1.8 | 0 | |
| Total % | 11.2 | 0.1 | 1.8 | 0 | 0.3 | 37.6 | 13.1 | 0 | 0.3 | 0.1 | 0.6 | 0 | 1.3 | 32.9 | 0.6 | 0 | |



MINNESOTA DEPT OF TRANSPORTATION

TRAFFIC DATA COLLECTION - METRO

Little Canada Rd at Country Dr.
 Ref.Pt.: (W of W ramps of I-35E)
 JAMAR # 631 RE
 TURN MOVEMENT COUNT

File Name : Little Canada Rd at Country Dr 2008
 Site Code : 00000000
 Start Date : 12/3/2008
 Page No : 3

| Start Time | Country Dr (Frontage Rd) Southbound | | | | | Little Canada Rd. Westbound | | | | | Gas Station entrance Northbound | | | | | Little Canada Rd. Eastbound | | | | | Int. Total |
|------------------------------------------------------|-------------------------------------|------|-------|------|------------|-----------------------------|------|-------|------|------------|---------------------------------|------|-------|------|------------|-----------------------------|------|-------|------|------------|------------|
| | Left | Thru | Right | Peds | App. Total | Left | Thru | Right | Peds | App. Total | Left | Thru | Right | Peds | App. Total | Left | Thru | Right | Peds | App. Total | |
| Peak Hour Analysis From 06:00 to 08:45 - Peak 1 of 1 | | | | | | | | | | | | | | | | | | | | | |
| Peak Hour for Entire Intersection Begins at 07:15 | | | | | | | | | | | | | | | | | | | | | |
| 07:15 | 37 | 0 | 6 | 0 | 43 | 2 | 205 | 73 | 0 | 280 | 1 | 0 | 2 | 0 | 3 | 10 | 79 | 3 | 0 | 92 | 418 |
| 07:30 | 26 | 0 | 10 | 0 | 36 | 0 | 265 | 77 | 0 | 342 | 0 | 0 | 2 | 0 | 2 | 0 | 85 | 2 | 0 | 87 | 467 |
| 07:45 | 24 | 0 | 8 | 0 | 32 | 4 | 269 | 120 | 0 | 393 | 1 | 0 | 5 | 0 | 6 | 2 | 86 | 1 | 0 | 89 | 520 |
| 08:00 | 28 | 0 | 8 | 0 | 36 | 0 | 221 | 93 | 0 | 314 | 0 | 0 | 1 | 0 | 1 | 5 | 93 | 1 | 0 | 99 | 450 |
| Total Volume | 115 | 0 | 32 | 0 | 147 | 6 | 960 | 363 | 0 | 1329 | 2 | 0 | 10 | 0 | 12 | 17 | 343 | 7 | 0 | 367 | 1855 |
| % App. Total | 78.2 | 0 | 21.8 | 0 | | 0.5 | 72.2 | 27.3 | 0 | | 16.7 | 0 | 83.3 | 0 | | 4.6 | 93.5 | 1.9 | 0 | | |
| PHF | .777 | .000 | .800 | .000 | .855 | .375 | .892 | .756 | .000 | .845 | .500 | .000 | .500 | .000 | .500 | .425 | .922 | .583 | .000 | .927 | .892 |

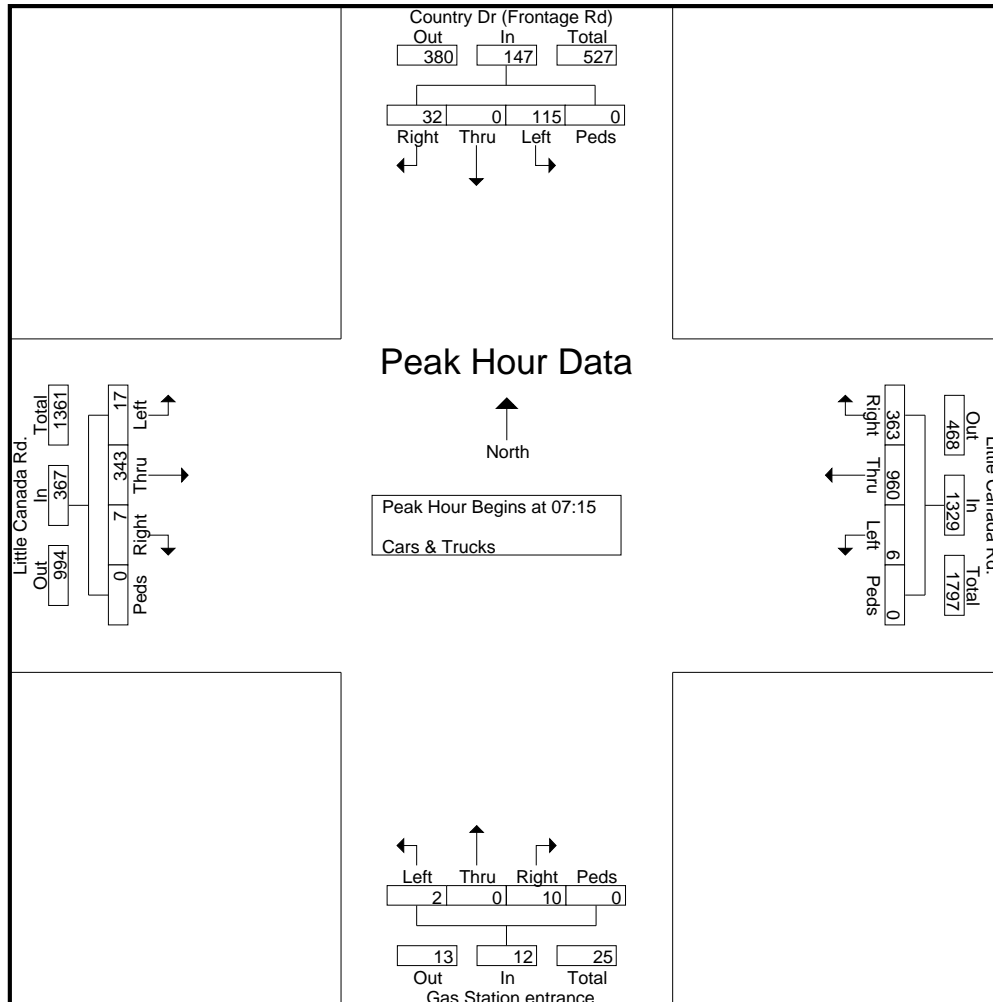



MINNESOTA DEPT OF TRANSPORTATION

TRAFFIC DATA COLLECTION - METRO

Little Canada Rd at Country Dr.
 Ref.Pt.: (W of W ramps of I-35E)
 JAMAR # 631 RE
 TURN MOVEMENT COUNT

File Name : Little Canada Rd at Country Dr 2008
 Site Code : 00000000
 Start Date : 12/3/2008
 Page No : 4

| Start Time | Country Dr (Frontage Rd) Southbound | | | | | Little Canada Rd. Westbound | | | | | Gas Station entrance Northbound | | | | | Little Canada Rd. Eastbound | | | | | Int. Total |
|------------|-------------------------------------|------|-------|------|------------|-----------------------------|------|-------|------|------------|---------------------------------|------|-------|------|------------|-----------------------------|------|-------|------|------------|------------|
| | Left | Thru | Right | Peds | App. Total | Left | Thru | Right | Peds | App. Total | Left | Thru | Right | Peds | App. Total | Left | Thru | Right | Peds | App. Total | |

Peak Hour Analysis From 14:45 to 17:45 - Peak 1 of 1

Peak Hour for Entire Intersection Begins at 16:00

| | | | | | | | | | | | | | | | | | | | | | |
|--------------|------|------|------|------|------|------|------|------|------|------|------|------|------|------|------|------|------|------|------|------|------|
| 16:00 | 81 | 0 | 8 | 0 | 89 | 0 | 166 | 58 | 0 | 224 | 0 | 0 | 0 | 0 | 0 | 5 | 162 | 0 | 0 | 167 | 480 |
| 16:15 | 58 | 0 | 5 | 0 | 63 | 0 | 164 | 38 | 0 | 202 | 0 | 0 | 0 | 0 | 0 | 5 | 167 | 0 | 0 | 172 | 437 |
| 16:30 | 86 | 2 | 8 | 0 | 96 | 4 | 117 | 40 | 0 | 161 | 0 | 0 | 3 | 0 | 3 | 8 | 170 | 4 | 0 | 182 | 442 |
| 16:45 | 46 | 1 | 12 | 0 | 59 | 2 | 141 | 41 | 0 | 184 | 1 | 1 | 8 | 0 | 10 | 4 | 182 | 2 | 0 | 188 | 441 |
| Total Volume | 271 | 3 | 33 | 0 | 307 | 6 | 588 | 177 | 0 | 771 | 1 | 1 | 11 | 0 | 13 | 22 | 681 | 6 | 0 | 709 | 1800 |
| % App. Total | 88.3 | 1 | 10.7 | 0 | | 0.8 | 76.3 | 23 | 0 | | 7.7 | 7.7 | 84.6 | 0 | | 3.1 | 96.1 | 0.8 | 0 | | |
| PHF | .788 | .375 | .688 | .000 | .799 | .375 | .886 | .763 | .000 | .860 | .250 | .250 | .344 | .000 | .325 | .688 | .935 | .375 | .000 | .943 | .938 |

