

ALLIANT ENGINEERING, INC.

733 S Marquette Ave #700, Minneapolis, MN 55402

Intersection: TH 65 & 40th Avenue
 Date: 10/29/2024
 Duration: 0600-1900

Site Code: 137
 Ref Pt: N/A
 Page No: 1 of 4

All Vehicles (Cars & Trucks) Printed

Start Time	TH 65 Southbound						40th Avenue Westbound						TH 65 Northbound						40th Avenue Eastbound						Int. Veh. Total	Int. Ped/ Bike Total
	U-Turn	Left	Thru	Right	App. Total	Peds/ Bikes	U-Turn	Left	Thru	Right	App. Total	Peds/ Bikes	U-Turn	Left	Thru	Right	App. Total	Peds/ Bikes	U-Turn	Left	Thru	Right	App. Total	Peds/ Bikes		
6:00	--	4	51	4	59	2	--	6	2	8	16	3	--	3	42	1	46	--	--	4	3	1	8	--	129	5
6:15	--	6	52	9	67	--	--	2	9	4	15	--	--	1	42	1	44	--	--	3	1	6	10	--	136	--
6:30	--	3	79	6	88	--	--	4	8	16	28	--	--	7	62	2	71	--	--	5	10	10	25	1	212	1
6:45	--	7	88	8	103	4	--	4	11	6	21	1	--	7	59	3	69	--	--	4	4	4	12	--	205	5
Hour Total	--	20	270	27	317	6	--	16	30	34	80	4	--	18	205	7	230	--	--	16	18	21	55	1	682	11
7:00	--	7	106	10	123	4	--	2	13	20	35	--	--	19	75	4	98	1	--	8	8	6	22	--	278	5
7:15	--	10	113	10	133	3	--	8	14	10	32	--	--	14	78	4	96	2	--	22	17	12	51	1	312	6
7:30	--	13	164	9	186	2	--	6	30	20	56	1	1	19	101	3	124	1	--	14	15	23	52	--	418	4
7:45	--	15	185	12	212	4	--	9	33	12	54	2	--	19	95	7	121	--	--	16	19	21	56	--	443	6
Hour Total	--	45	568	41	654	13	--	25	90	62	177	3	1	71	349	18	439	4	--	60	59	62	181	1	1451	21
8:00	1	21	182	22	226	5	--	10	13	13	36	--	--	9	90	8	107	1	--	24	13	16	53	2	422	8
8:15	1	9	204	19	233	2	--	4	26	14	44	4	--	9	82	2	93	--	--	13	14	13	40	1	410	7
8:30	--	14	143	15	172	4	--	8	20	15	43	4	1	12	96	5	114	1	--	16	23	15	54	--	383	9
8:45	1	15	130	13	159	5	--	11	22	16	49	2	--	10	84	5	99	--	--	16	14	13	43	3	350	10
Hour Total	3	59	659	69	790	16	--	33	81	58	172	10	1	40	352	20	413	2	--	69	64	57	190	6	1565	34
9:00	1	11	107	8	127	1	--	1	13	25	39	1	1	13	89	4	107	--	--	19	15	20	54	--	327	2
9:15	1	15	109	11	136	7	--	6	11	19	36	2	--	13	99	8	120	2	--	13	12	13	38	1	330	12
9:30	--	14	124	14	152	1	--	7	12	16	35	3	--	6	111	5	122	2	1	5	7	6	19	--	328	6
9:45	--	11	123	18	152	1	--	8	10	17	35	1	--	8	106	8	122	3	--	17	13	22	52	3	361	8
Hour Total	2	51	463	51	567	10	--	22	46	77	145	7	1	40	405	25	471	7	1	54	47	61	163	4	1346	28
10:00	1	16	96	13	126	2	--	11	10	18	39	10	2	12	99	3	116	3	--	21	5	13	39	3	320	18
10:15	--	12	104	18	134	2	--	4	13	18	35	2	--	19	124	6	149	--	--	9	11	8	28	3	346	7
10:30	--	12	123	10	145	4	--	5	8	11	24	4	5	10	85	8	108	3	--	19	13	12	44	3	321	14
10:45	--	6	119	13	138	1	--	3	16	10	29	6	--	18	107	6	131	2	--	25	11	21	57	1	355	10
Hour Total	1	46	442	54	543	9	--	23	47	57	127	22	7	59	415	23	504	8	--	74	40	54	168	10	1342	49
11:00	--	15	114	10	139	3	--	9	10	13	32	4	--	13	105	14	132	1	--	20	6	14	40	4	343	12
11:15	--	12	134	19	165	4	--	8	11	17	36	3	--	10	121	10	141	2	--	27	14	14	55	5	397	14
11:30	1	10	132	13	156	7	--	7	11	15	33	3	1	16	128	11	156	2	--	14	15	17	46	5	391	17
11:45	--	15	126	16	157	1	--	7	11	19	37	8	--	10	119	14	143	2	--	21	22	32	75	2	412	13
Hour Total	1	52	506	58	617	15	--	31	43	64	138	18	1	49	473	49	572	7	--	82	57	77	216	16	1543	56
12:00	--	17	124	14	155	3	--	4	17	25	46	5	1	10	137	10	158	1	--	14	18	8	40	4	399	13
12:15	1	21	122	24	168	--	--	10	12	17	39	1	--	13	128	13	154	3	--	30	19	12	61	1	422	5
12:30	--	17	110	15	142	5	--	12	20	16	48	6	1	13	125	13	152	4	--	25	18	23	66	2	408	17
12:45	--	19	143	22	184	4	--	17	17	18	52	6	3	6	110	12	131	1	--	27	23	21	71	1	438	12
Hour Total	1	74	499	75	649	12	--	43	66	76	185	18	5	42	500	48	595	9	--	96	78	64	238	8	1667	47
13:00	--	20	112	11	143	11	--	12	14	22	48	2	1	12	114	11	138	3	--	15	36	24	75	5	404	21
13:15	--	23	96	7	126	--	--	8	12	18	38	5	1	8	130	13	152	5	--	18	20	14	52	2	368	12
13:30	--	15	110	16	141	6	--	17	20	24	61	2	2	15	131	13	161	7	--	15	20	20	55	3	418	18
13:45	--	11	101	16	128	2	--	16	19	28	63	6	1	17	143	14	175	4	--	25	25	16	66	--	432	12
Hour Total	--	69	419	50	538	19	--	53	65	92	210	15	5	52	518	51	626	19	--	73	101	74	248	10	1622	63
14:00	2	23	112	17	154	1	--	20	17	20	57	3	2	13	137	18	170	4	--	20	18	20	58	1	439	9
14:15	3	20	121	20	164	2	--	11	20	23	54	6	2	10	153	11	176	1	--	23	27	16	66	--	460	9
14:30	--	23	146	19	188	5	--	10	12	32	54	6	--	15	153	11	179	7	--	24	18	17	59	6	480	24
14:45	--	25	111	14	150	3	--	12	21	28	61	2	2	17	154	15	188	3	--	33	23	20	76	8	475	16
Hour Total	5	91	490	70	656	11	--	53	70	103	226	17	6	55	597	55	713	15	--	100	86	73	259	15	1854	58
15:00	2	23	155	21	201	3	--	12	19	21	52	3	--	20	170	10	200	2	--	28	22	28	78	1	531	9
15:15	--	20	174	27	221	7	--	12	29	15	56	5	--	16	147	17	180	--	--	27	31	23	81	7	538	19
15:30	2	23	169	12	206	6	--	9	24	18	51	3	1	16	168	17	202	3	--	13	24	26	63	6	522	18
15:45	1	18	136	18	173	5	--	6	25	23	54	8	1	14	156	8	179	4	--	20	30	21	71	3	477	20
Hour Total	5	84	634	78	801	21	--	39	97	77	213	19	2	66	641	52	761	9	--	88	107	98	293	17	2068	66
16:00	2	19	144	17	182	9	--	8	33	24	65	10	1	14	206	12	233	5	--	18	24	18	60	6	540	30
16:15	--	17	160	21	198	3	--	10	34	27	71	4	1	19	168	9	197	7	--	30	29	26	85	3	551	17
16:30	--	21	166	20	207	6	--	16	23	23	62	5	2	22	167	18	209	3	--	26	33	26	85	2	563	16
16:45	--	24	131	20	175	8	--	15	33	37	85	6	1	23	180	17	221	7	--	22	40	22	84	3	565	24
Hour Total																										

ALLIANT ENGINEERING, INC.

733 S Marquette Ave #700, Minneapolis, MN 55402

Intersection: TH 65 & 40th Avenue
 Date: 10/29/2024
 Duration: 0600-1900

Site Code: 137
 Ref Pt: N/A
 Page No: 2 of 4

All Vehicles (Cars & Trucks) Printed

Start Time	TH 65 Southbound						40th Avenue Westbound						TH 65 Northbound						40th Avenue Eastbound						Int. Veh. Total	Int. Ped/Bike Total
	U-Turn	Left	Thru	Right	App. Total	Peds/Bikes	U-Turn	Left	Thru	Right	App. Total	Peds/Bikes	U-Turn	Left	Thru	Right	App. Total	Peds/Bikes	U-Turn	Left	Thru	Right	App. Total	Peds/Bikes		
7:30	--	13	164	9	186	2	--	6	30	20	56	1	1	19	101	3	124	1	--	14	15	23	52	--	418	4
7:45	--	15	185	12	212	4	--	9	33	12	54	2	--	19	95	7	121	--	--	16	19	21	56	--	443	6
8:00	1	21	182	22	226	5	--	10	13	13	36	--	--	9	90	8	107	1	--	24	13	16	53	2	422	8
8:15	1	9	204	19	233	2	--	4	26	14	44	4	--	9	82	2	93	--	--	13	14	13	40	1	410	7
Hour Total	2	58	735	62	857	13	--	29	102	59	190	7	1	56	368	20	445	2	--	67	61	73	201	3	1693	25
% of App.	0.2%	6.8%	85.8%	7.2%			0.0%	15.3%	53.7%	31.1%			0.2%	12.6%	82.7%	4.5%			0.0%	33.3%	30.3%	36.3%				
% of Total	0.1%	3.4%	43.4%	3.7%	50.6%	52.0%	0.0%	1.7%	6.0%	3.5%	11.2%	28.0%	0.1%	3.3%	21.7%	1.2%	26.3%	8.0%	0.0%	4.0%	3.6%	4.3%	11.9%	12.0%		
Cars Total	2	54	699	59	814	13	--	28	99	55	182	7	1	52	350	20	423	2	--	58	58	69	185	3	1604	25
Cars % of Movement	100%	93.1%	95.1%	95.2%	95.0%	52.0%	0.0%	96.6%	97.1%	93.2%	95.8%	28.0%	100%	92.9%	95.1%	100%	95.1%	8.0%	0.0%	86.6%	95.1%	94.5%	92.0%	12.0%	94.7%	
Trucks Total	--	4	36	3	43	--	--	1	3	4	8	--	--	4	18	--	22	--	--	9	3	4	16	--	89	--
Trucks % of Movement	0.0%	6.9%	4.9%	4.8%	5.0%	--	0.0%	3.4%	2.9%	6.8%	4.2%	--	0.0%	7.1%	4.9%	0.0%	4.9%	--	0.0%	13.4%	4.9%	5.5%	8.0%	--	5.3%	

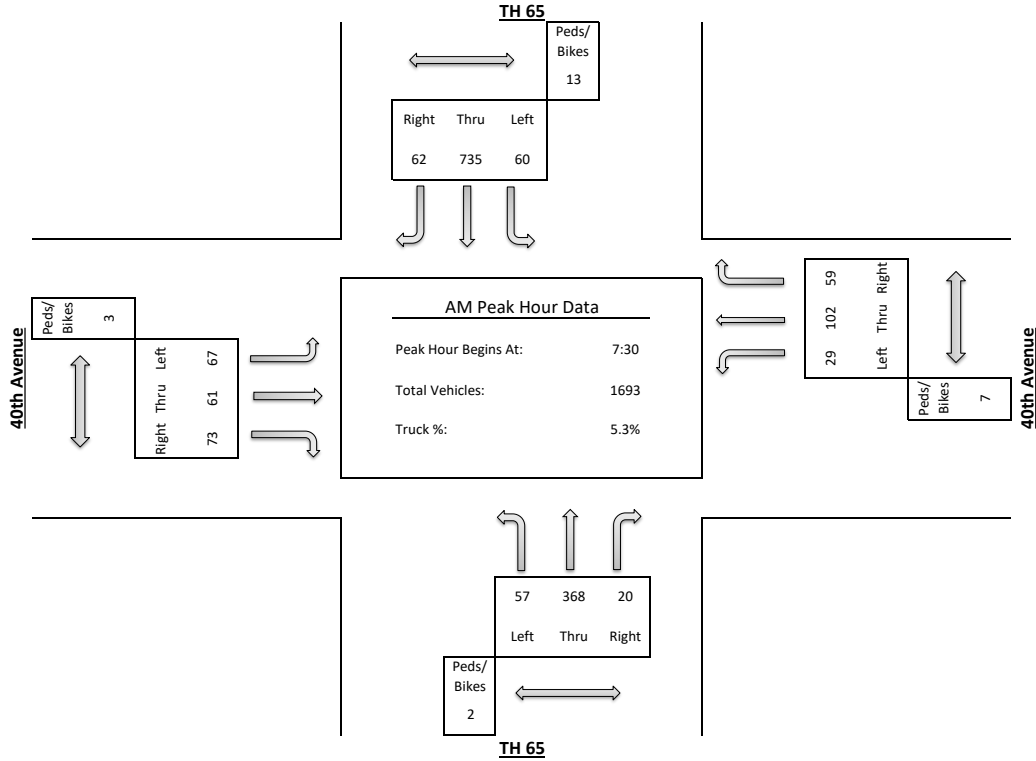

ALLIANT ENGINEERING, INC.

733 S Marquette Ave #700, Minneapolis, MN 55402

Intersection: TH 65 & 40th Avenue
 Date: 10/29/2024
 Duration: 0600-1900

Site Code: 137
 Ref Pt: N/A
 Page No: 3 of 4

All Vehicles (Cars & Trucks) Printed

Start Time	TH 65 Southbound						40th Avenue Westbound						TH 65 Northbound						40th Avenue Eastbound						Int. Veh. Total	Int. Ped/Bike Total
	U-Turn	Left	Thru	Right	App. Total	Peds/Bikes	U-Turn	Left	Thru	Right	App. Total	Peds/Bikes	U-Turn	Left	Thru	Right	App. Total	Peds/Bikes	U-Turn	Left	Thru	Right	App. Total	Peds/Bikes		
12:15	1	21	122	24	168	--	--	10	12	17	39	1	--	13	128	13	154	3	--	30	19	12	61	1	422	5
12:30	--	17	110	15	142	5	--	12	20	16	48	6	1	13	125	13	152	4	--	25	18	23	66	2	408	17
12:45	--	19	143	22	184	4	--	17	17	18	52	6	3	6	110	12	131	1	--	27	23	21	71	1	438	12
13:00	--	20	112	11	143	11	--	12	14	22	48	2	1	12	114	11	138	3	--	15	36	24	75	5	404	21
Hour Total	1	77	487	72	637	20	--	51	63	73	187	15	5	44	477	49	575	11	--	97	96	80	273	9	1672	55
% of App.	0.2%	12.1%	76.5%	11.3%			0.0%	27.3%	33.7%	39.0%			0.9%	7.7%	83.0%	8.5%			0.0%	35.5%	35.2%	29.3%				
% of Total	0.1%	4.6%	29.1%	4.3%	38.1%	36.4%	0.0%	3.1%	3.8%	4.4%	11.2%	27.3%	0.3%	2.6%	28.5%	2.9%	34.4%	20.0%	0.0%	5.8%	5.7%	4.8%	16.3%	16.4%		
Cars Total	1	75	467	67	610	18	--	51	63	72	186	14	5	43	457	48	553	9	--	94	94	79	267	6	1616	47
Cars % of Movement	100%	97.4%	95.9%	93.1%	95.8%	38.3%	0.0%	100%	100%	98.6%	99.5%	29.8%	100%	97.7%	95.8%	98.0%	96.2%	19.1%	0.0%	96.9%	97.9%	98.8%	97.8%	12.8%	96.7%	
Trucks Total	--	2	20	5	27	2	--	--	--	1	1	1	--	1	20	1	22	2	--	3	2	1	6	3	56	8
Trucks % of Movement	0.0%	2.6%	4.1%	6.9%	4.2%	25.0%	0.0%	0.0%	0.0%	1.4%	0.5%	12.5%	0.0%	2.3%	4.2%	2.0%	3.8%	25.0%	0.0%	3.1%	2.1%	1.3%	2.2%	37.5%	3.3%	

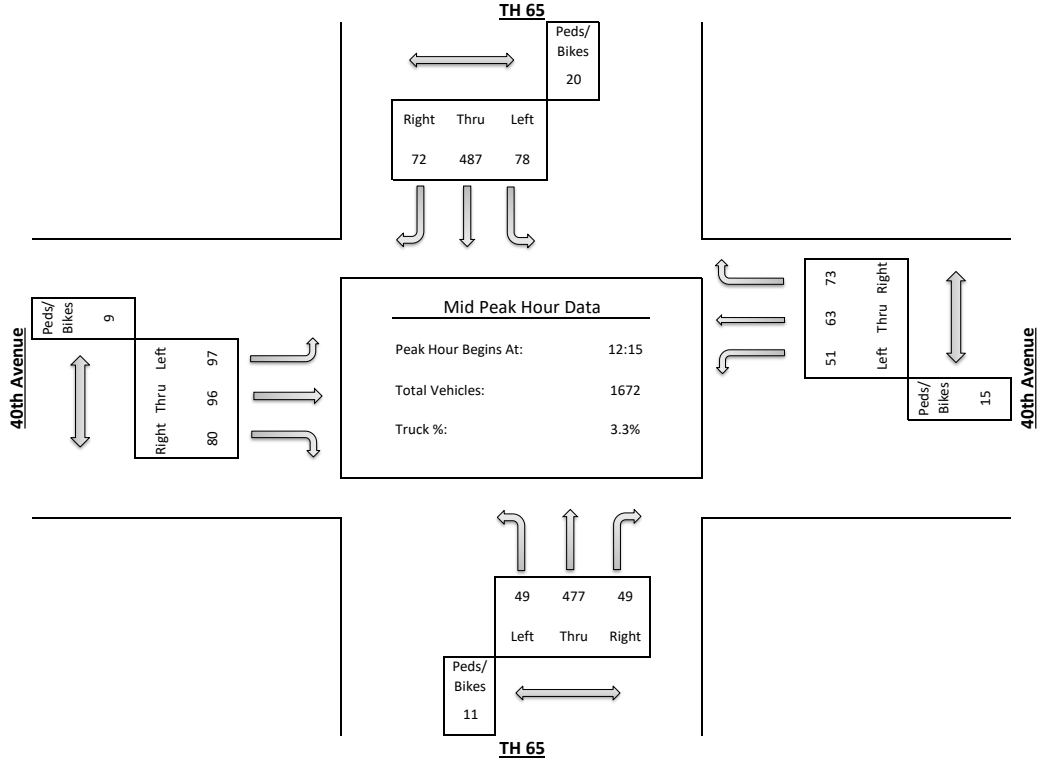

ALLIANT ENGINEERING, INC.

733 S Marquette Ave #700, Minneapolis, MN 55402

Intersection: TH 65 & 40th Avenue
 Date: 10/29/2024
 Duration: 0600-1900

Site Code: 137
 Ref Pt: N/A
 Page No: 4 of 4

All Vehicles (Cars & Trucks) Printed

Start Time	TH 65 Southbound						40th Avenue Westbound						TH 65 Northbound						40th Avenue Eastbound						Int. Veh. Total	Int. Ped/Bike Total	
	U-Turn	Left	Thru	Right	App. Total	Peds/Bikes	U-Turn	Left	Thru	Right	App. Total	Peds/Bikes	U-Turn	Left	Thru	Right	App. Total	Peds/Bikes	U-Turn	Left	Thru	Right	App. Total	Peds/Bikes			
16:30	--	21	166	20	207	6	--	16	23	23	62	5	2	22	167	18	209	3	--	26	33	26	85	2	563	16	
16:45	--	24	131	20	175	8	--	15	33	37	85	6	1	23	180	17	221	7	--	22	40	22	84	3	565	24	
17:00	--	19	166	12	197	2	--	12	33	20	65	4	--	18	179	15	212	3	--	21	32	12	65	2	539	11	
17:15	--	26	147	29	202	3	--	11	27	33	71	6	1	24	169	16	210	4	--	25	27	25	77	2	560	15	
Hour Total	--	90	610	81	781	19	--	54	116	113	283	21	4	87	695	66	852	17	--	94	132	85	311	9	2227	66	
% of App.	0.0%	11.5%	78.1%	10.4%			0.0%	19.1%	41.0%	39.9%			0.5%	10.2%	81.6%	7.7%			0.0%	30.2%	42.4%	27.3%					
% of Total	0.0%	4.0%	27.4%	3.6%	35.1%	28.8%	0.0%	2.4%	5.2%	5.1%	12.7%	31.8%	0.2%	3.9%	31.2%	3.0%	38.3%	25.8%	0.0%	4.2%	5.9%	3.8%	14.0%	13.6%			
Cars Total	--	88	598	78	764	19	--	54	115	111	280	19	4	85	679	66	834	17	--	91	132	83	306	9	2184	64	
Cars % of Movement	0.0%	97.8%	98.0%	96.3%	97.8%	29.7%	0.0%	100%	99.1%	98.2%	98.9%	29.7%	100%	97.7%	97.7%	100%	97.9%	26.6%	0.0%	96.8%	100%	97.6%	98.4%	14.1%	98.1%		
Trucks Total	--	2	12	3	17	--	--	1	2	3	2	--	2	16	--	18	--	--	--	--	3	--	2	5	--	43	2
Trucks % of Movement	0.0%	2.2%	2.0%	3.7%	2.2%	0.0%	0.0%	0.9%	1.8%	1.1%	100.0%	0.0%	0.0%	2.3%	2.3%	0.0%	2.1%	0.0%	0.0%	3.2%	0.0%	2.4%	1.6%	0.0%	1.9%		

