

SPRING 2016

WHAT WILL HAPPEN?

STAGE 1

SHOULDER & INSIDE LANE CONSTRUCTION

I-94 between Mounds Blvd & Century Ave

 Build Shoulder & Inside Lane for Length of Project

 Shift Westbound & Eastbound Traffic Outward

 Up to 3 Months of Work

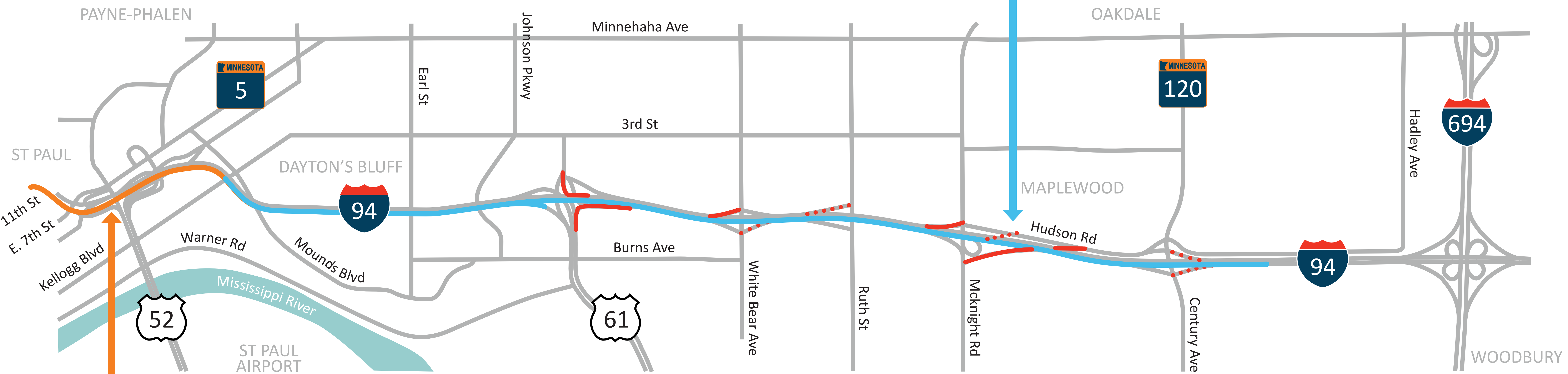

Duration and time frames are all approximate and weather dependent. Plans are subject to change.

AUXILIARY LANE CONSTRUCTION

11th St to Mounds Blvd

 Build Auxiliary Lane

 Shoulder Closure

 1 Month of Work

Eastbound I-94 Access to Lafayette Bridge Closed

RAMP IMPROVEMENTS

Short-term closures: 

Short-term closures are planned for approximately two weeks.

- I-94 EB entrance from White Bear Ave
- I-94 WB entrance from Ruth St
- I-94 WB exit to Century Ave
- I-94 EB entrance from Century Ave
- I-94 WB entrance from Hudson Rd (one ramp)

Long-term closures: 

Long-term closures are planned for as long as the duration of the construction stage.

- I-94 EB entrance from US 61 NB
- I-94 EB entrance from Etna St
- I-94 WB entrance from White Bear Ave
- I-94 EB entrance from McKnight Rd
- I-94 WB entrance from McKnight Rd
- I-94 WB entrance from Hudson Rd (one ramp)

 Replace Ramp Pavement or Temporary Work

 Ramp Closures

 Short-term Ramp Closures Will Be Intermittent

SUMMER 2016

WHAT WILL HAPPEN?

STAGE 2

WB PAVEMENT REPLACEMENT

Mounds Blvd to Century Avenue



Replace Pavement



4 Months of Work



Route Westbound Traffic Around Construction Zone – At Least Two Lanes in Each Direction Will Be Provided

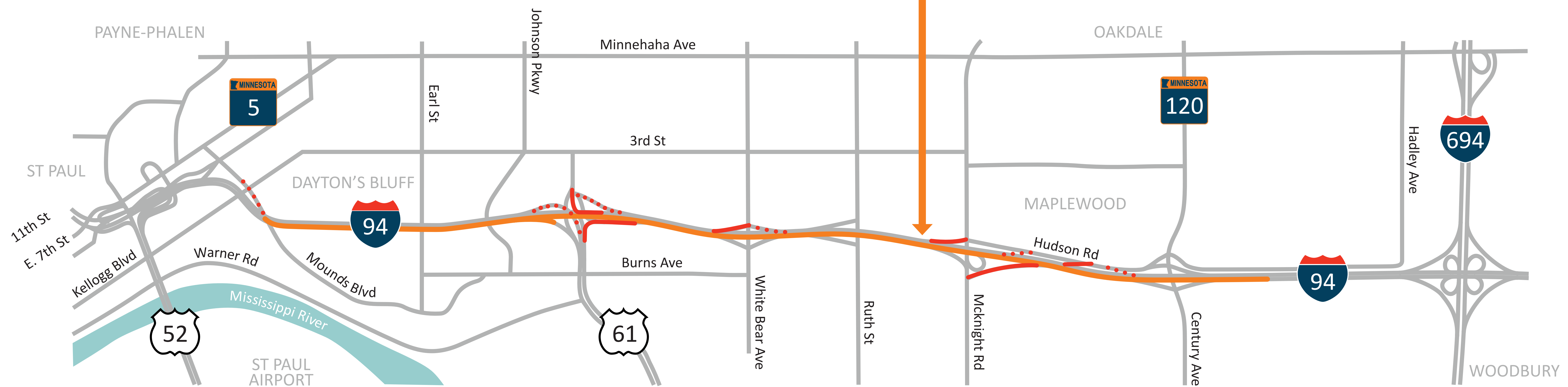

Duration and time frames are all approximate and weather dependent.

RAMP IMPROVEMENTS

Short-term closures:

Short-term closures are planned for approximately two weeks.

- I-94 WB exit to Mounds Blvd
- I-94 WB entrance from US 61 NB
- I-94 WB exit to Etna St
- I-94 WB exit to White Bear Avenue
- I-94 WB entrance from Hudson Rd (one ramp)
- I-94 WB exit to Hudson Rd

Long-term closures: ———

Long-term closures are planned for as long as the duration of the construction stage.

- I-94 EB entrance from US 61 NB
- I-94 EB entrance from Etna St
- I-94 WB entrance from White Bear Ave
- I-94 EB entrance from McKnight Rd
- I-94 WB entrance from McKnight Rd
- I-94 WB entrance from Hudson Rd (one ramp)



Replace Ramp Pavement or Temporary Work



Ramp Closures



Short-term Ramp Closures Will Be Intermittent

HOW WILL CONSTRUCTION CREWS DO THE WORK?

MnDOT is breaking construction into two parts rather than shutting down the entire highway. Crews will replace pavement on the westbound lanes in 2016 and the eastbound lanes in 2017.

Expect ramp closures throughout construction. Some will be short-term and others will be long-term.

Duration and time frames are all approximate and weather-dependent.



2016

- Replace *westbound* pavement
- Route westbound traffic around construction area

westbound

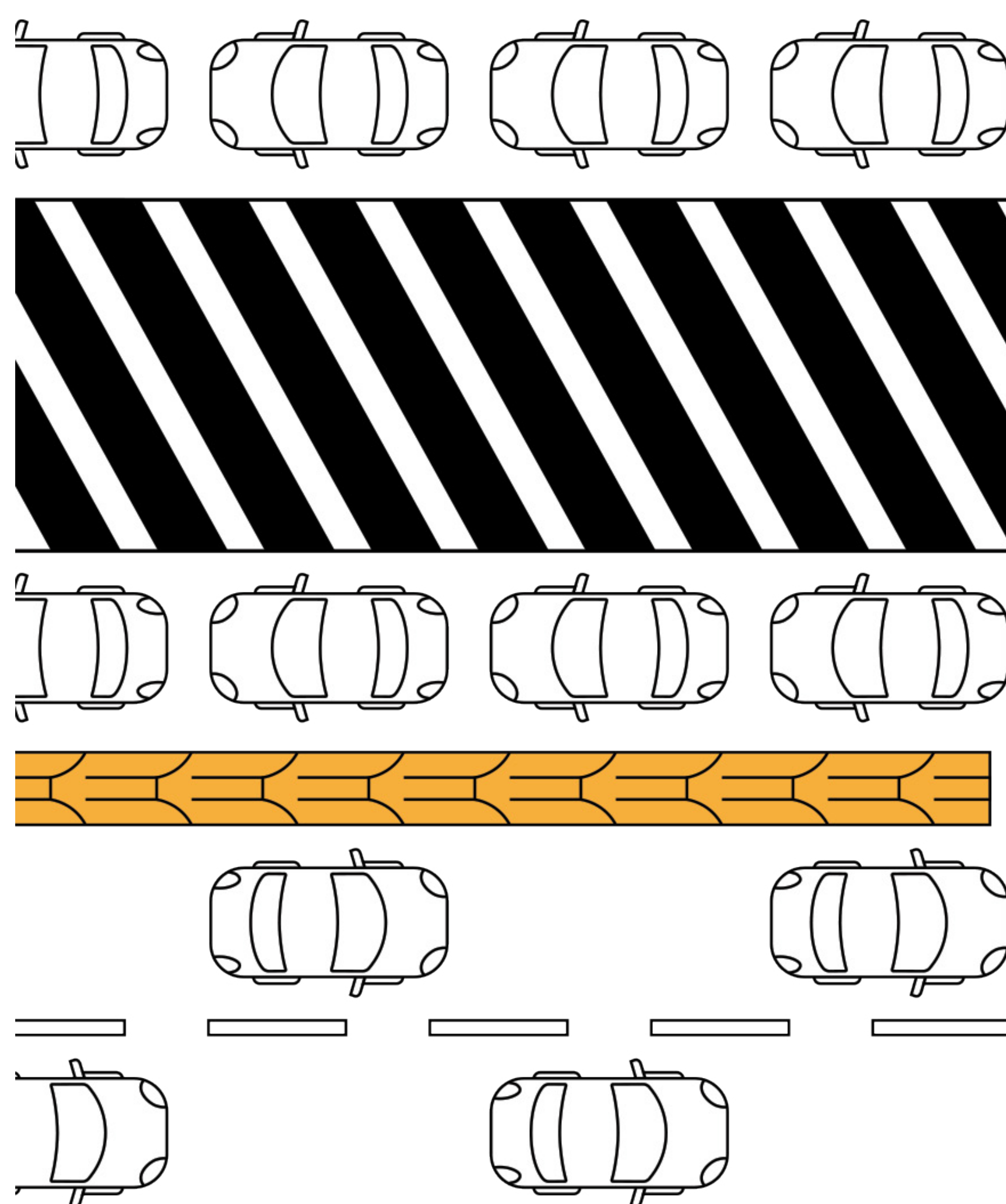

2017

- Replace *eastbound* pavement
- Route eastbound traffic around construction area

eastbound

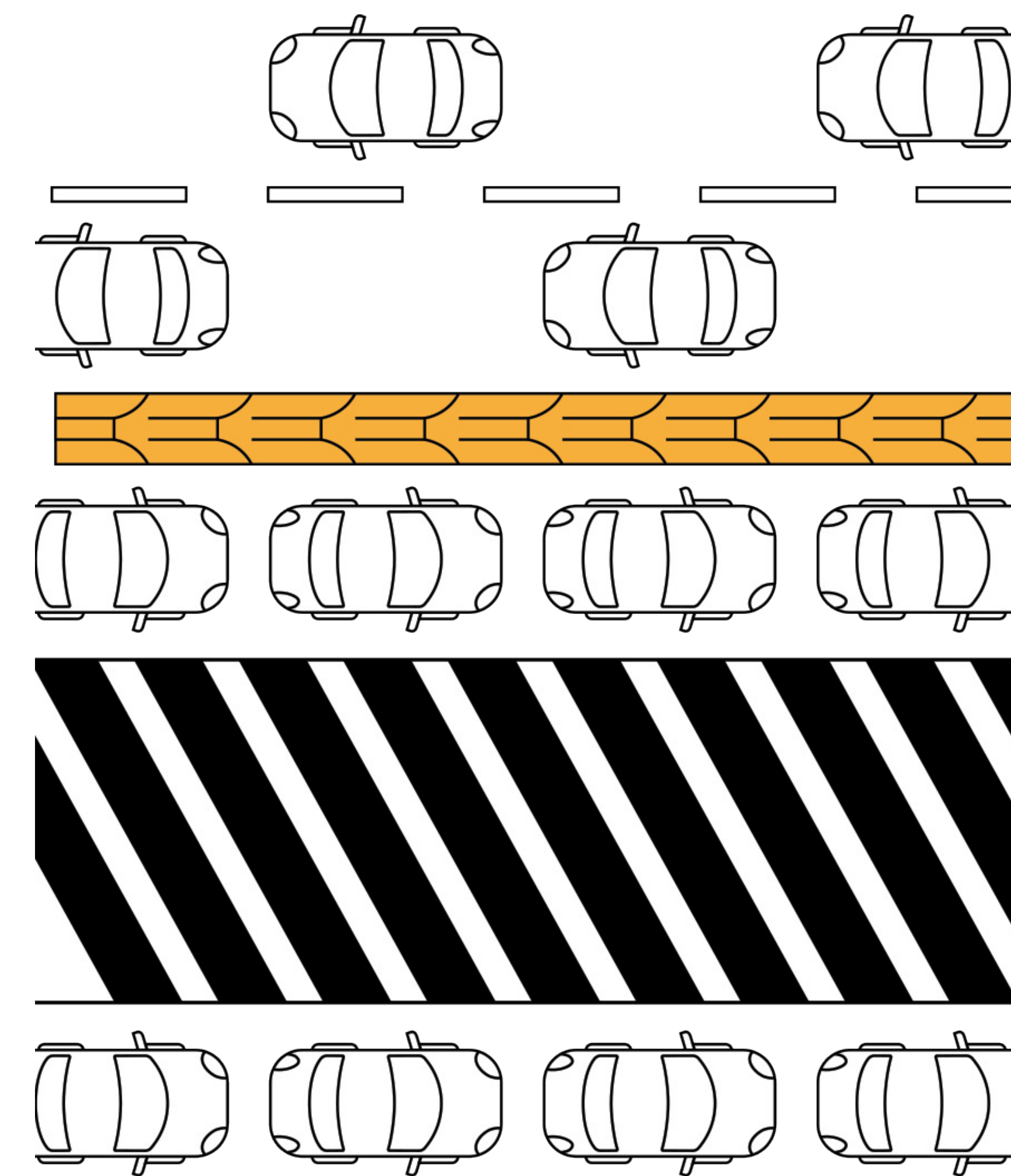

*Illustrations are conceptual. Duration and time frames are all approximate and weather dependent. Plans are subject to change.

HOW WILL I DRIVE THROUGH THE AREA?

Be prepared to choose a lane.

If you are driving through the construction zone, follow the “through traffic stay left” signs. You will not have access to on and off ramps while in the left lane.

If you need to get off the highway within the construction area, stay right, following the “local access stay right” signs. You will be able to get on and off the highway in the right lane.



LEFT

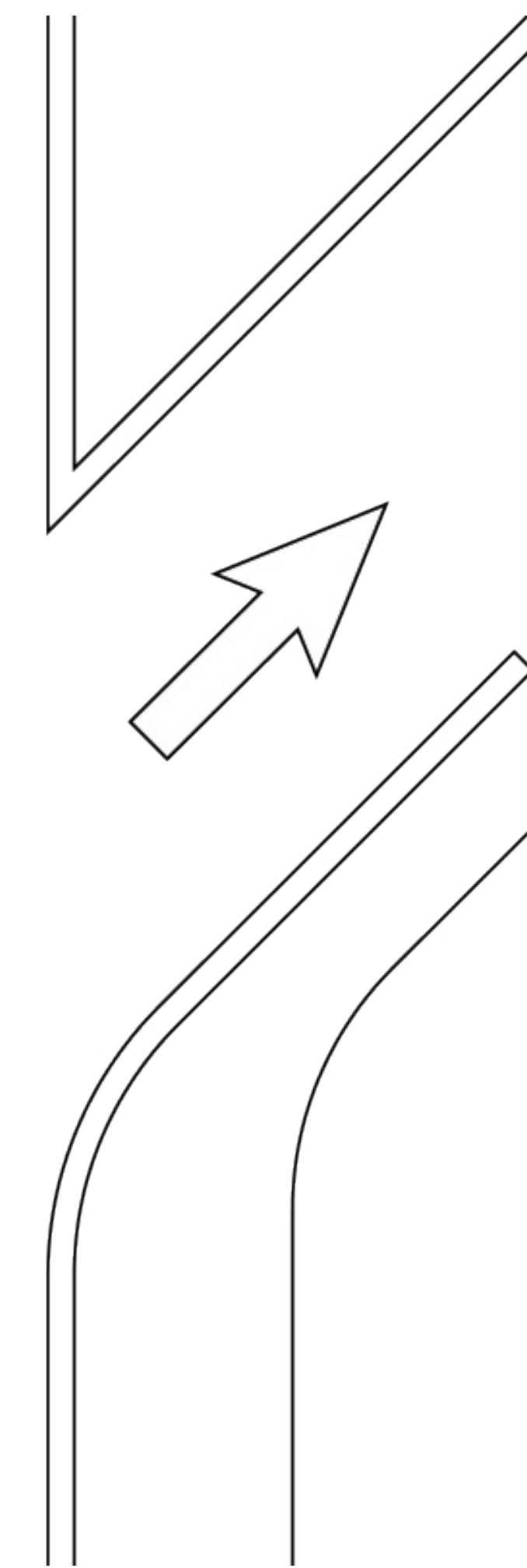
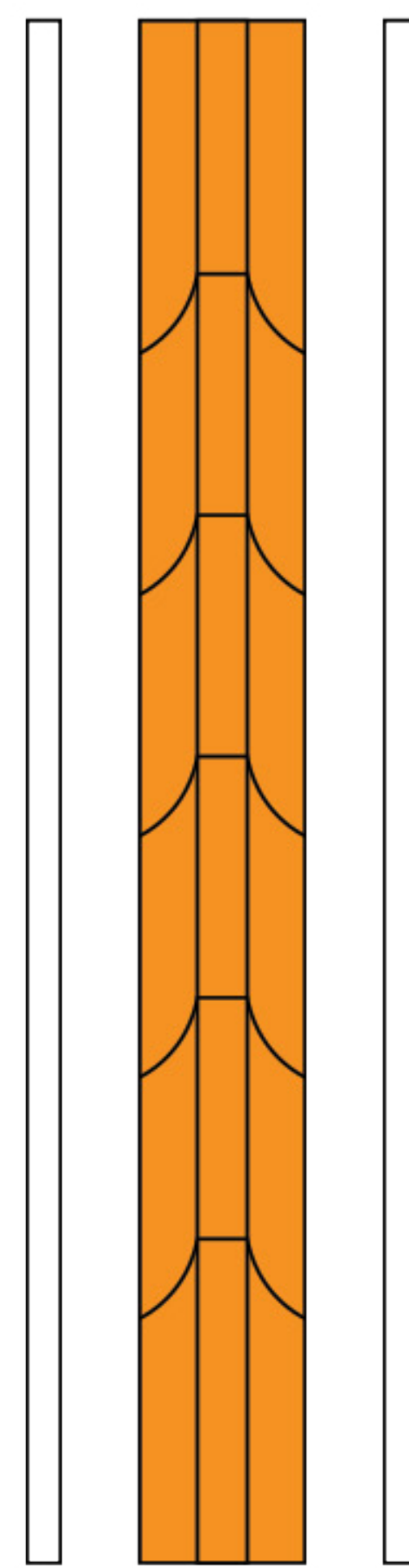

Through Traffic Stay *Left*:

- Direct route through construction area
- Motorists **WILL NOT** be able to access on/off ramps in the construction area

RIGHT

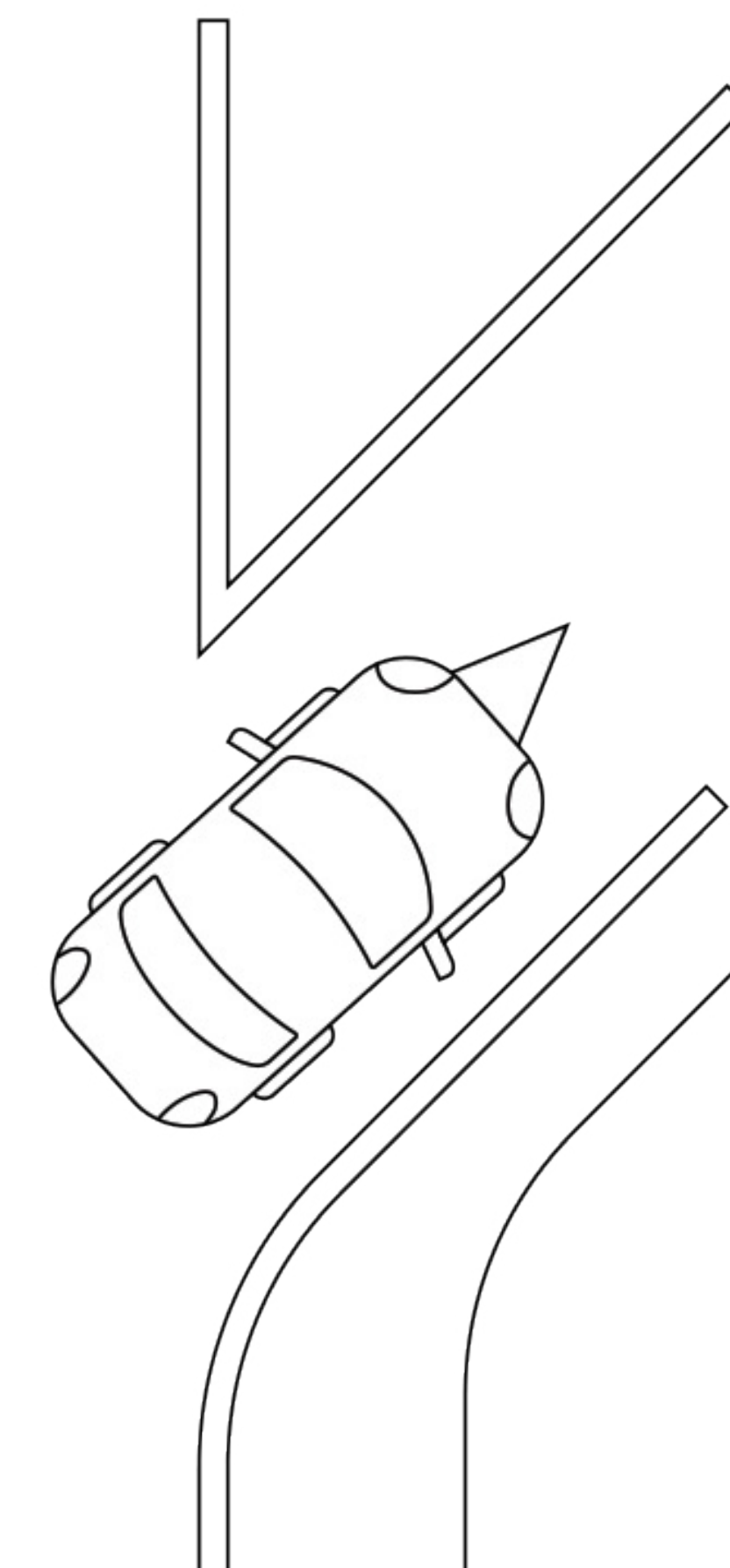
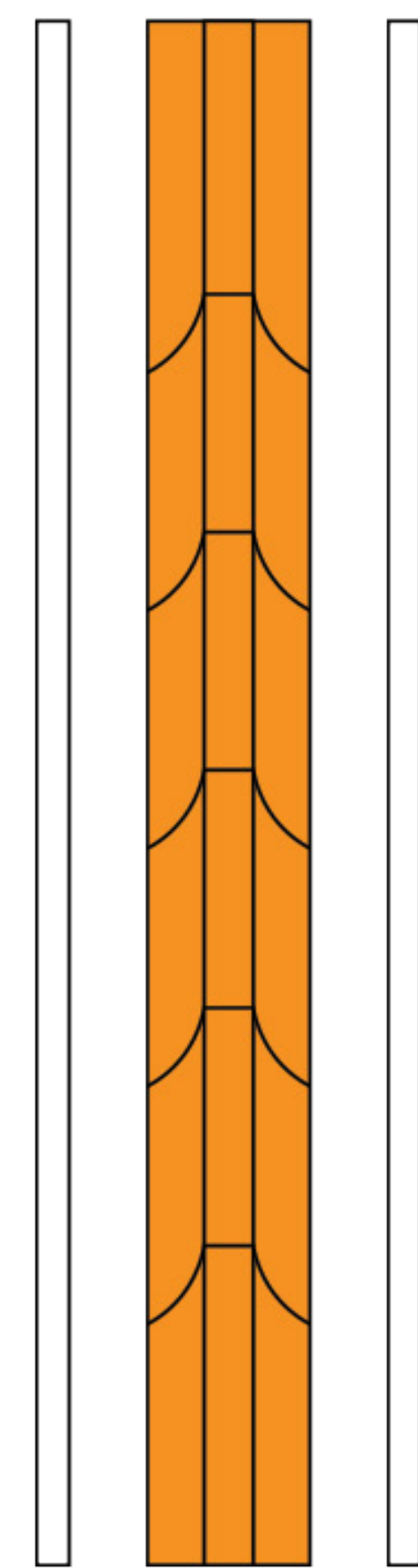

Local Access Stay *Right*:

- Route allows motorists to get on and off the highway within the construction area