

Minnesota Department of Transportation Agreement Number: 73807P

Minnesota Intelligent Transportation Systems

Statewide Intelligent Transportation Systems As-Is Agency Reports for Minnesota



Volume 2 Mn/DOT Traffic Management Center

Prepared for the Minnesota Department of Transportation by:

Lockheed Martin Federal Systems-Owego
Intelligent Transportation Systems
Mail Drop 0124
1801 State Route 17C
Owego, NY 13827-3998

SRF Consulting Group, Inc.
One Carlson Parkway North
Suite 150
Minneapolis, MN 55447-4443

August 1996

Statewide ITS As-Is Agency Report for Minnesota

Volume 2

Mn/DOT Traffic Management Center

Volume 1 Mn/DOT Metropolitan Division

- 1.1 Generic Closed Loop Traffic Control Signal System
- 1.2 Mn/DOT Advanced Portable Traffic Management System
- 1.3 Mn/DOT Portable Traffic Management System
- 1.4 Mn/DOT Metro Division Lane Closure Information System
- 1.5 Mn/DOT Metro Division Construction Information System

Volume 2 Mn/DOT Traffic Management Center

- 2.1 Mn/DOT TMC Ramp Meter System**
- 2.2 Mn/DOT TMC Video Surveillance System**
- 2.3 Mn/DOT TMC Changeable Message Sign System**
- 2.4 Mn/DOT TMC Communications System**
- 2.5 Mn/DOT TMC Highway Helper AVL System**

Volume 3 Operational Tests

- 3.1 AUSCI - Adaptive Urban Signal Control and Integration System
- 3.2 ICTM - Integrated Corridor Traffic Management System
- 3.3 DIVERT Incident Management System
- 3.4 Advanced Parking Information System

Volume 4 Metropolitan Council Transit Operations and Metro Mobility

- 4.1 MCTO Trapeze Scheduling/Planning System
- 4.2 MCTO Automated Passenger Counting System
- 4.3 MCTO Electronic Fare Collection System
- 4.4 MCTO TIC BusLine System
- 4.5 MCTO TIC Customer Phone Line Service System
- 4.6 Metropolitan Council Metro Mobility Reservation/Scheduling/Dispatch System
- 4.7 MCTO Construction Information System

Volume 5 City of Minneapolis

- 5.1 City of Minneapolis Fortran Traffic Signal Control System
- 5.2 City Of Minneapolis Parking Management System
- 5.3 City Of Minneapolis Construction Information System

Volume 6 City of St. Paul

- 6.1 City of St. Paul Computran Traffic Signal Control System
- 6.2 City Of St. Paul Construction Information System

Volume 7 Minnesota State Patrol

- 7.1 Minnesota State Patrol Mobile Data Terminal System
- 7.2 Minnesota State Patrol Laptop Mobile Data Terminal System
- 7.3 Minnesota State Patrol Emergency 911 Dispatch System

Volume 8 Miscellaneous

- 8.1 Minnesota Travel Partners Kiosk System
- 8.2 Mn/DOT Pavement Condition And Weather Reporting System
- 8.3 Hennepin County Medical Center Emergency Vehicle Dispatch System

- 8.4 Metropolitan Airports Commission Parking Management and AVI System
- 8.5 Gopher State One-Call Excavation Notification System
- 8.6 Mn/DOT Statewide Construction Information System
- 8.7 Hennepin County Construction Information System
- 8.8 Ramsey County Construction Information System
- 8.9 Mn/DOT ESS Gopher State One-Call Access System

**Statewide ITS As-Is Agency Report for Minnesota
Volume 2
Mn/DOT Traffic Management Center**

1	Introduction	1
2	Scope	2
2.1	Document Overview	2
2.2	Methods, Assumptions and Procedures	2
2.2.1	System Identification	2
2.2.2	Data Collection Guide	3
2.2.3	Field Data Collection.....	3
3	As-Is Baseline System Documentation	5
3.2	Mn/DOT Traffic Management Center	7
3.2.1	Mn/DOT TMC Ramp Meter System.....	9
3.2.2	Mn/DOT TMC Video Surveillance System	19
3.2.3	Mn/DOT TMC Changeable Message Sign System.....	29
3.2.4	Mn/DOT TMC Communications System	39
3.2.5	Mn/DOT TMC Highway Helper AVL System	49

Appendices

Appendix A As-Is Agency Report for Minnesota Pre-Survey Candidate List

Appendix B As-Is Agency Report for Minnesota Data Collection Guide

1. INTRODUCTION

The purpose of the Polaris Project is to define an Intelligent Transportation Systems (ITS) architecture for the state of Minnesota. An architecture is a framework that defines a complex system, in terms of a set of smaller, more manageable systems which are fully defined in terms of their individual boundaries, functions, physical components, and interfaces. They illustrate how each of the systems interrelate and contribute to the overall ITS objectives and requirements.

A well defined architecture provides many benefits for a complex system. It defines and optimizes the location of system functions. It identifies critical interfaces, and illustrates how associated systems can be integrated to share resources and information. It establishes standards for communications and physical components so that inter-operability can be maintained as the system evolves to incorporate new capabilities and technologies.

The Minnesota Statewide ITS Architecture is a tailored version of the National ITS Architecture. Tailoring incorporates the prioritized wants and needs of the state's transportation users and stakeholders, as well as its existing ITS infrastructure. The functional architecture, physical architecture, system requirements and implementation plan are fully documented in the following project deliverables:

ITS Traveler Wants/ Needs - Information obtained from Minnesota residents in ten end user sessions held across the state. Used to establish and prioritize end-user requirements.

ITS Transportation Wants/ Needs - Information obtained from ITS stakeholder institutions. Used to establish and prioritize ITS service provider requirements.

ITS Wants/ Needs Analysis - Final results and recommendations of the wants and needs research.

Statewide ITS As-Is Agency Reports for Minnesota - Information about existing transportation systems that establish the starting point for the Architecture Implementation Plan.

ITS System Specification - Incorporates the results of the functional and physical architectures into specification format. The specification will clearly identify ITS system level requirements for the identified Minnesota ITS services.

ITS Component Specification - Incorporates the results of the functional to physical allocation in specification format. The specification will clearly identify the Minnesota ITS component systems requirements.

ITS Architecture Implementation Plan - A recommended ITS deployment strategy for future state initiatives.

2. SCOPE

This document, *Statewide ITS As-Is Agency Reports for Minnesota*, consists of a collection of individual system survey reports related to transportation systems. The Polaris Project will use the survey information collected to derive the existing architectural framework. After the existing architectural framework is derived, this information will be used as the baseline for developing the Minnesota Statewide ITS Architecture.

Agencies identified and contributed to this document were:

- Minnesota Department of Transportation Office of Advanced Transportation Systems
- Minnesota Department of Transportation Traffic Management Center
- Minnesota Department of Transportation Metropolitan Division
- Minnesota Department of Transportation Electrical Services Section
- St. Paul Department of Public Works
- Minneapolis Department of Public Works
- Hennepin County Department of Public Works
- Ramsey County Department of Public Works
- Minnesota State Patrol
- Hennepin County Medical Center
- Metropolitan Council Transit Operations
- Metropolitan Airports Commission
- Gopher State One Call
- Minnesota Office of Tourism

2.1 Document Overview

This document presents the methods, assumptions and procedures used to collect the baseline information. The documentation of systems that were inventoried is presented in Section 3.

2.2 Methods, Assumptions, and Procedures

2.2.1 System Identification

Agency and system candidates were based upon several factors prior to survey. Through market research, the highest wants and needs priorities for traveler and transportation related agencies identified the functional areas to be improved (i.e. Travel Conditions). The Polaris Project took the functional wants and needs and associated the wants and needs functions to current Minnesota Agencies. Another factor that contributed to identifying the candidate agencies was the presence of existing Intelligent Transportation Systems infrastructure that has been deployed to support integrating open systems for travelers, inter-agency and intra-agency needs.

One hundred twenty one pre-survey candidate systems identified by the process described previously, are listed in Appendix A. The pre-survey candidate list represents systems that were known by members of the Polaris Architecture working team, Mn/DOT Guidestar, and SRF Consulting Group, Inc. Of the 121 candidate systems, 38 system surveys were performed and

included in this document. The 38 systems were selected as best representatives of the 121 pre-survey candidates and provided a diverse base of information to use for developing the Minnesota Statewide ITS Architecture.

2.2.2 Data Collection Guide

The survey of systems required that a standard data collection approach be applied for the *Statewide ITS As-Is Agency Reports for Minnesota*. A data collection guide was prepared to help this effort.

The data collection guide was developed to provide interviewers with an overview of relevant information that needed to be collected during the survey for each system. The data collection effort focused on the following:

- A block diagram of the system and interfaces to external users and systems.
- All hardware elements that are interconnected to form the bounds of the system.
- All software components used by the hardware elements.
- All system interfaces that connect hardware components together and external systems to the system.
- All personnel using the system.

The Data Collection Guide is presented in Appendix B.

2.2.3 Field Data Collection

The survey collection activities were completed by two teams of interviewers. Prior to an on-site interview, an agency or system contact person was briefed as to the nature of the survey. In some cases, generally where agencies knew little of the Polaris project, a follow-up letter was sent to further outline the desired level of information.

The on-site interview was generally a free format discussion of the specific system elements. The data collection guide was only used to ensure all components were discussed. The interviewers recorded the audio portion of the interview in order to help with the documentation of the system. Where possible, the actual system components were also recorded on videotape, again, to help with the system documentation. In some cases, written documentation from the agency was reviewed to help describe the system.

A report of the surveyed system followed a standard format and consisted of two basic parts: 1) a system block diagram and 2) a data collection template. The block diagram is intended to depict the system components and interfaces while the template thoroughly describes the system configuration. The template is organized to step through the system related personnel, hardware, software and interfaces. All systems documented for the project used this standardized approach. The system documentation was separated by agencies into eight volumes.

The system reports contained in this volume follow in Section 3.

3. AS-IS BASELINE SYSTEM DOCUMENTATION

3.2 MN/DOT TRAFFIC MANAGEMENT CENTER

- 3.1.1 Mn/DOT TMC Ramp Meter System
- 3.1.2 Mn/DOT TMC Video Surveillance System
- 3.1.3 Mn/DOT TMC Changeable Message Sign System
- 3.1.4 Mn/DOT TMC Communications System
- 3.1.5 Mn/DOT TMC Highway Helper AVL System

3.2.1 MN/DOT TMC RAMP METER SYSTEM

Baseline Data Collection
mp Meter System

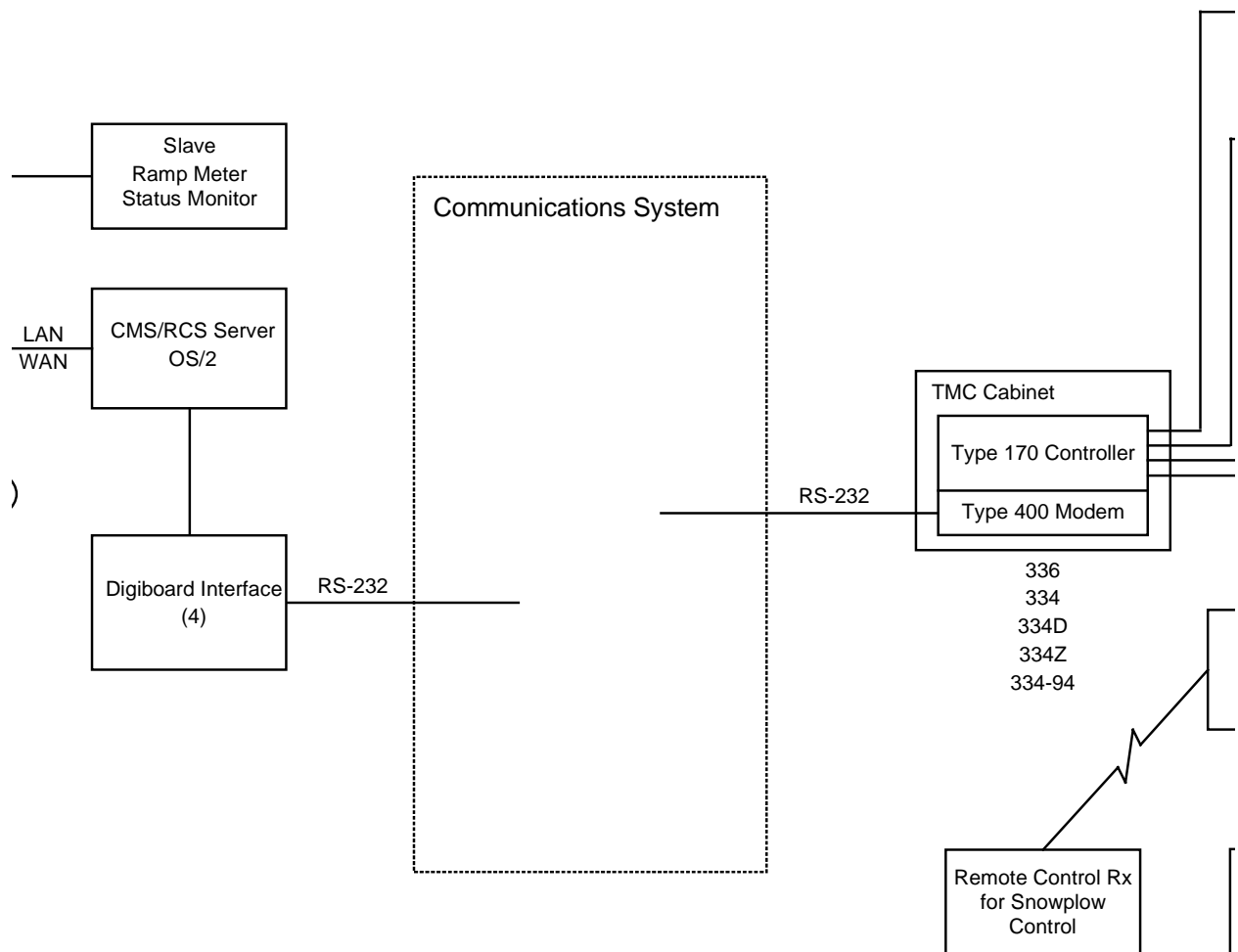

AS-IS DATA COLLECTION TEMPLATE

1.0 AGENCY AMN/DOT TRAFFIC MANAGEMENT CENTER@

- Agency Type Traffic Management
- Agency Functions Manage traffic on Twin City area freeway system.
- Agency Location(s) 1101 4th Avenue South
Minneapolis, MN 55404

2.0 SYSTEM AMN/DOT TMC RAMP METER SYSTEM@

- Date of As-Is Data Collection 2/15/96
- Purpose To control the flow of traffic centering the freeway system to optimize the flow of traffic on the mainline.
- Hours of Operation 6 AM - 9 PM M-F, 11 AM - 6 PM Sat., 10 AM - 5 PM Sun. and as needed for construction, special events and emergencies.
- Geographic Coverage Twin Cities Metro Area (TCMA) freeways.
- Contacts Rich Lau, Patty Bednarz, Terry Haukom
- Status Existing - 380 ramps metered - 350 online (490 ramps will be metered by 1998).
Approximately 160 miles of freeway covered by this system.

2.1 PERSONNEL ATMC OPERATOR@

- Personnel Function Monitor traffic management system devices and utilize information to manage traffic congestion, incidents and provide motorist information.
- Quantity 2 operators work during peak period shifts, 1 operator during off-peak shifts.
- Location Traffic Management Center control room.
- Workload High. Each operator has a multitude of devices to monitor, assimilate information and make real time decisions.
- Working hours Each operator works a shift of 3-4 hours.
Weekend shifts are 8 hours.
- Status Existing

3.1 HARDWARE ACMS PC & MONITOR@

- Hardware Type Computer
- Functions Display status of traffic management devices.
Accept device control commands and forward to CMS/RCS PC Server.
- Location TMC Control Room
- Data Name/Contents
 - 1) Changeable Message Sign messages
 - 2) Changeable Message Sign status
 - 3) Lane Control Signal Status
 - 4) HAR sign status
 - 5) Ramp Control Signal status
- Data Type Data
- Status Existing
- Other Ron Dahl

3.2 HARDWARE ACMS/RCS SERVER@

- Hardware Type Computer
- Functions
 - 1) Poll 170 controllers
 - 2) Receive ramp meter status and loop detector data (volume/occupancy) from the Type 170 controllers.
 - 3) Write loop detector data to database.
 - 4) Compute ramp meter rates using loop detector data (30 second loop detector station volume and occupancy).
 - 5) Send control commands to ramp meter 170 controllers.
 - 6) Maintain traffic history database of 5 minute loop data.
 - 7) Generate congestion status map.
- Location TMC - Computer Room
- Data Name/Contents
 - 1)Changeable Message Sign messages
 - 2) Changeable Message Sign status
 - 3) Lane Control Signal Status
 - 4) HAR sign status
 - 5) Ramp Control Signal status
 - 6) Loop detector volume/occupancy data
- Data Type Data
- Status Existing
- Other Ron Dahl

3.3 HARDWARE ADIGIBOARD INTERFACE@

- Hardware Type Router
- Functions Allows a PC to interface to multiple (up to 256) RS-232 communication ports.
- Location TMC Computer Room
- Data Name/Contents
 - 1) Changeable Message Sign messages
 - 2) Changeable Message Sign status
 - 3) Lane Control Signal Status
 - 4) Ramp Control Signal status
 - 5) Loop detector volume/occupancy data
- Data Type Data
- Status Existing

3.4 HARDWARE ATYPE 170 CONTROLLER@

- Hardware Type Traffic Signal Controller
- Functions Receives ramp metering rate commands from the TMC central computer and controls variable message signs and lane control signals.
- Location In field cabinet near lane control signals or within the interchange where ramp meter is installed.
- Data Name/Contents
 - 1) Line number
 - 2) Drop number
 - 3) Ramp number
 - 4) Ramp metering rate (rate 1-6, or 7=flash)
 - 5) Ramp meter status
 - 6) Loop detector data (volume and occupancy)
- Data Type Data
- Status Existing

3.4.1 SOFTWARE A170 CONTROLLER SOFTWARE@

- Software Type Transportation software application
- Software Standards Custom - written by TMC personnel
- Functions Operate devices which interface with 170 controller:
 - Detector Amplifiers
 - Power Distribution Assembly (Ramp Control Signals, Advance Warning Flashers, Gatearms)
 - Store loop detector data.
 - Communicate with CMS/RCS server.
 - Send loop detector data to CMS/RCS server when polled.
 - Receives verification/status signals from gatearms and provides status to CMS/RCS server.
- Application Language Motorola 6800 Assembler Language
- Status Existing

3.5 HARDWARE ARAMP CONTROL SIGNAL@

- Hardware Type Traffic Signal
- Functions Display visual indication to traveler to control traffic entering freeway on a ramp. Visual indication is either:
 - 1) Yellow flashing bulb
 - 2) Green - Yellow - Red cycling bulb.
- Location On most entrance ramps onto freeways in Metro Area. One ramp control signal is required for each entrance ramp lane.
Ramp control signals are usually placed approximately 250 feet from end of concrete nose. This allows vehicles to accelerate from a dead stop to 40-45 mph at the point of merge with freeway traffic.
- Status Existing - 380 ramps metered - 350 online
490 ramps will be metered by 1998.
- Policies Most ramps have dual lane metering.
With the exception of the 10th Street ramp to I-35W southbound, all ramp meters are one car per green.
- Constraints Isolated ramp control signals are constrained to running by a fixed time clock.
Two signal heads are required for each lane.
Voltage drop/luminance standards.
- Issues Ramp control signals getting knocked down in winter is a problem.

3.6 HARDWARE AADVANCE WARNING FLASHER@

- Hardware Type Traffic Signal
- Functions Display visual indication to traveler approaching freeway entrance to warn driver that ramp is being metered and that a queue may exist. Visual indication is a yellow flashing bulb.
- Location On high speed roadways approaching freeway entrance ramps where ramp meter and queue is not visible from approach roadway.
- Status Existing, but not at all ramp meters.

3.7 HARDWARE AVEHICLE DETECTORS@

- Hardware Type Detector
- Functions Detect vehicles, record number of vehicles passing over a traffic lane (volume) and the time that the detector's detection zone was occupied by a vehicle (occupancy).
- Location In traffic lane
- Data Name/Contents Volume - number of vehicles passing over a traffic lane.
Occupancy - the time that the detector's detection zone was occupied by a vehicle.
- Data Type Data
- Status Existing

3.8 HARDWARE AGATEARMS@

- Hardware Type Gatearm - traffic control device
- Functions Physically block the entrance to a the HOV lane when gatearm is in down position.
- Location On lanes leading into I-394 HOV lane.
- Status Existing
- Policies Gatearms are connected to 170 controllers and the TMC control room to allow TMC operators to open and close gatearms. This method is not used. Gatearms (HOV lane) are opened in the field by Mn/DOT Highway Helper personnel.
- Other Manual Gatearm Switch allows Mn/DOT personnel to open and close gatearms in the field. Remote Control receiver allows a Mn/DOT snowplow driver to open a set of gatearms long enough for a snowplow to pass through during plow operations.

4.1 INTERFACE

- Connects to ...

- Interface location
- Interface Type
- Interface Direction
- Interface Component
- Protocol/Standard
- Information Type/Content
- Information Direction

TYPE 170 CONTROLLER

Ramp control signals, advance warning flasher, changeable message signs, variable message signs and lane control signs.

In field.

Power

Both

Power conductor cables and twisted pair cable.

120 VAC

Power

Output

4.2 INTERFACE

- Connects to ...
- Interface location
- Interface Type
- Interface Direction
- Interface Component

- Information Type/Content

- Information Direction
- Information Frequency

TYPE 170 CONTROLLER

Vehicle Detectors

In field.

Data - low voltage current - frequency delta.

Both

Detector amplifier in cabinet connected to detector lead-in cable which is connected to vehicle detector.

Volume - number of vehicles passing over a traffic lane.

Occupancy - the time that the detector's detection zone was occupied by a vehicle.

Input

24 hour/day

4.3 INTERFACE

- Connects to ...
- Interface location
- Interface Type
- Interface Direction
- Interface Component

- Protocol/Standard
- Information Type/Content

TYPE 170 CONTROLLER

Communication System

In field.

Data

Both

Type 400 modem connected to copper twisted pair, and fiber optic cable.

RS-232

1) Detector volume - number of vehicles passing over a traffic lane.

2) Detector occupancy - the time that the detector's detection zone was occupied by a vehicle.

3) Station volume and occupancy - the average volume and occupancy data measured over all detectors in one detector station (freeway direction) for the last 30 second time interval.

4) 170 controller line number

5) 170 controller drop number

6) Ramp number

7) Ramp metering rate (rate 1-6, or 7=flash)

8) Ramp meter status

- Information Direction
- Information Frequency
- Information Standards

Both

30 seconds

1200 and 2400 baud

4.4 INTERFACE

- Connects to ...
- Interface location
- Interface Type
- Interface Direction
- Interface Component
- Protocol/Standard
- Information Type/Content

CMS/RCS SERVER

TMC Communications System

TMC

Data

Both

Twisted pair and fiber optic cable

RS-232

1) Detector volume - number of vehicles passing over a traffic lane.

2) Detector occupancy - the time that the detector's detection zone was occupied by a vehicle.

3) Station volume and occupancy - the average volume and occupancy data measured over all detectors in one detector station (freeway direction) for the last 30 second time interval.

4) 170 controller line number

5) 170 controller drop number

6) Ramp number

7) Ramp metering rate (rate 1-6, or 7=flash)

8) Ramp meter status

- Information Direction

Both

- Information Frequency

Once per minute

- Information Standards

1200 and 2400 baud

3.2.2 MN/DOT TMC VIDEO SURVEILLANCE SYSTEM

Baseline Data Collection
Video Surveillance System

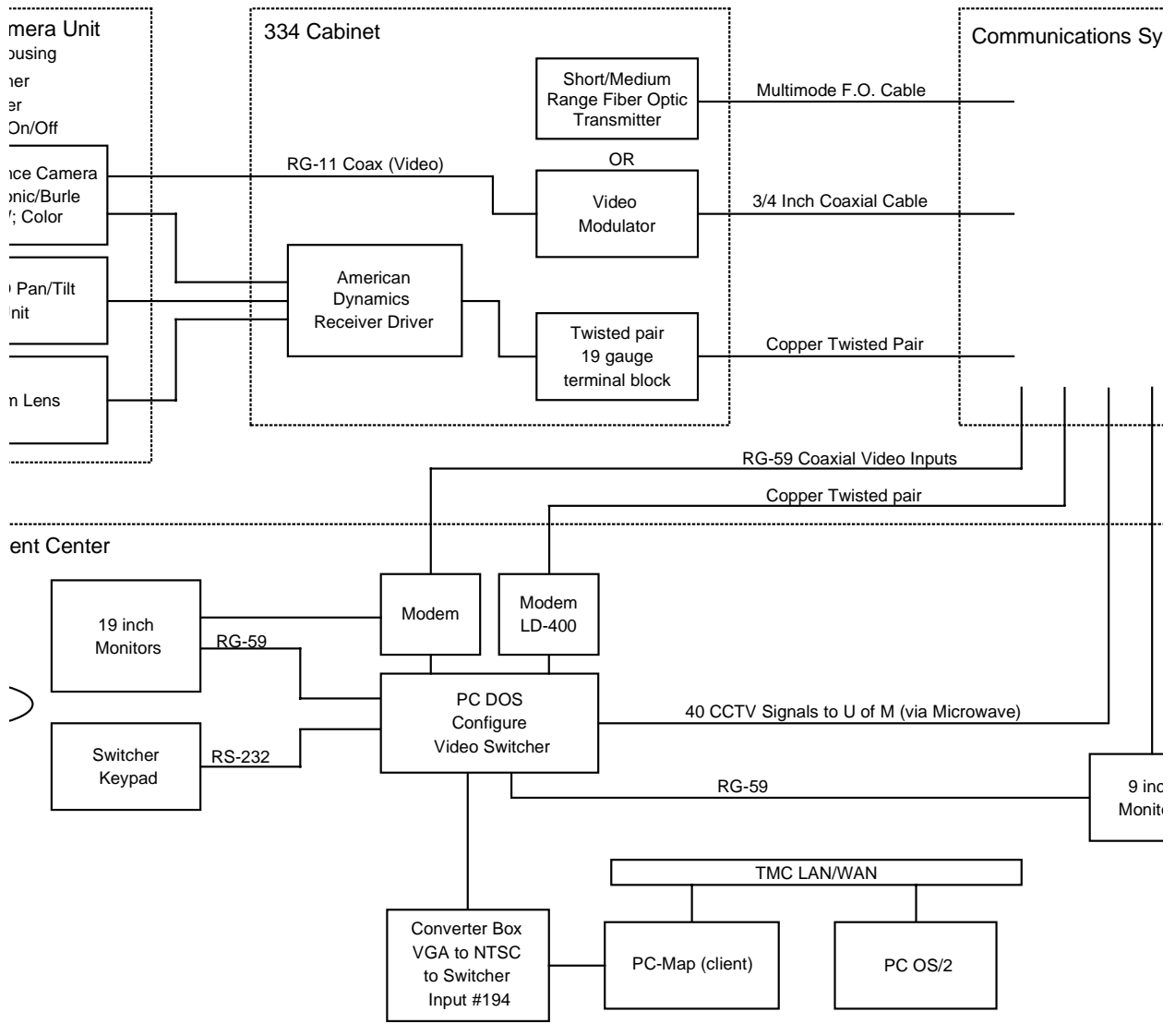

AS-IS DATA COLLECTION TEMPLATE

1.0 AGENCY AMN/DOT TRAFFIC MANAGEMENT CENTER@

- Agency Type Traffic Management
- Agency Functions Design, Operate, Evaluate Freeway Traffic Management System
- Agency Location(s) 1101 4th Ave. S., Minneapolis. MN 55404

2.0 SYSTEM AMN/DOT TMC VIDEO SURVEILLANCE SYSTEM@

- Date of As-Is Data Collection 1/15/96
- Purpose
 - 1) Verification of incidents on Twin Cities Metropolitan Area (TCMA) freeways.
 - 2) Verification of ramp meter operations
 - 3) Traffic management aid
 - 4) Incident management
- Hours of Operation 6:00 AM - 7:30 PM M-F, 10:00 AM - 6:00 PM Saturday, and 11:00 AM -7:00 PM Sunday at TMC
24 hrs/day at Metro District and St. Patrol
- Geographic Coverage TCMA freeway system
- Contacts Rich Lau, Patty Bednarz, Terry Haukom
- Status 156 Cameras are currently in place
- Policies Install CCTV camera at intervals as needed for coverage of TCMA freeway system.

2.1 PERSONNEL ATMC OPERATOR@

- Personnel Function Monitor traffic management system devices and utilize to manage traffic congestion, incidents and provide motorist information.
- Quantity 2 operators work during peak period shifts, 1 operator during off-peak shifts.
- Location Traffic Management Center control room.
- Workload High. Each operator has a multitude of devices to monitor, assimilate information and make real time decisions.
- Working hours Each operator works a shift of 3-4 hours on weekdays. Weekend shifts are 8 hours.
- Status Existing

3.1 HARDWARE ATMC VIDEO SWITCHER@

- Hardware Type Video switcher
- Functions Receiver video signal from up to 214 inputs and provide for routing of any incoming video signal to any one of 64 video outputs as directed by operator. Place identifiers on video output signal (CCTV #, locations, direction, time and date along freeway). Switcher computer maintains database of CCTV locations, identifiers, outputs, etc. Switcher manages requests from operator keypads based on administrator-s controls.
- Location TMC communications room (basement)
- Data Name/Contents Surveillance video
- Data Type Video
- Status Existing
- Constraints 214 video inputs should be adequate capacity for TCMA freeway, however the 64 outputs is limiting the ability to transmit video signals to other agencies.
- Recommended Improvements Project to replace switcher is funded and programmed for 1996.
- Other American Dynamics Inc.
Switcher will be replaced in 1996 to provide 256 inputs and 128 outputs.

3.2 HARDWARE ASURVEILLANCE CAMERA@

- Hardware Type Camera
- Functions Capture live video pictures, convert to analog signal.
- Location Typically mounted on 50' pole adjacent to freeway on Mn/DOT R/W spaced at approximately 1 mile intervals. 7 cameras mounted atop 4 high rise buildings along I-94 corridor between Minneapolis and St. Paul.
- Data Type Real time video signal - NTSC baseband video.
- Status Existing at 156 locations. Planned for X locations.
- Policies Install CCTV cameras along all 250+ miles of TCMA freeways.
- Constraints Cameras can view 2 mile of freeway in each direction, therefore each camera can monitor 1 mile of freeway. Cameras limited to 350 degree rotation.
- Recommended Improvements Existing Black & White cameras will be replaced with color cameras in the future.
- Other Panasonic 350, 350C and Burle cameras.

3.3 HARDWARE APELCO PAN/TILT UNIT@

- Hardware Type Motors
- Functions Pan and tilt the surveillance camera.
- Location Typically mounted on 50' pole adjacent to freeway on Mn/DOT R/W spaced at approximately 1 mile intervals. 7 cameras mounted atop 4 high rise buildings along I-94 corridor between Minneapolis and St. Paul.
- Data Name/Contents None
- Data Type None
- Status Existing
- Constraints Since cables are attached to camera unit, camera can only rotate 350 degrees.

3.4 HARDWARE AZOOM LENS@

- Hardware Type Camera Lens
- Functions Zoom in on incident to provide better view.
- Location Mounted on end of camera.
- Data Name/Contents Video
- Data Type Video
- Status Existing
- Policies Typically use a 12X lens, (15 --> 180)

3.5 HARDWARE AAMERICAN DYNAMICS RECEIVER DRIVER@

- Hardware Type Communications receiver.
- Functions Receives control command messages from video switcher, converts to power outputs to control camera devices.
Converts RS-232 signal from the TMC to Manchester.
- Location 334 Cabinet near Camera pole.
- Data Name/Contents Control for camera, lens, pan/tilt, washer/wiper.
- Data Type Data
- Status Existing

3.6 HARDWARE ASHORT/MEDIUM RANGE FIBER OPTIC TRANSMITTER@

- Hardware Type Transmitter
- Functions Converts NTSC baseband video signal to signal and transmits onto multi-mode fiber optic cable into Communication System.
- Location 334 Cabinet near Camera pole.
- Data Name/Contents Surveillance video signal
- Data Type Video
- Status Existing
- Constraints Short range Tx has maximum 1.5 mile transmission range.
Medium range Tx has maximum 4.9 mile transmission range.
- Other Short range transmits at 850 nm, Medium range transmits at 1300 nm.

3.7 HARDWARE AVIDEO MODULATOR@

- Hardware Type Converts NTSC baseband video signal to AM RF signal with other camera signals and transmits onto coaxial cable into Communication System.
- Functions Cabinet near Camera pole.
- Location Surveillance video signal
- Data Name/Contents Video
- Data Type Existing

3.8 HARDWARE ASWITCHER KEYPAD@

- Hardware Type Keypad
- Functions Via a joystick, number pad, and function keys, this keypad is used by the Operator to:
 - 1) select cameras and route camera signal to video monitor
 - 2) move cameras
 - 3) control all camera functions such as pan, tilt, zoom, washer, etc
- Location TMC Control Room, State Patrol Dispatch, Metro Maintenance Dispatch, MCTO, City of Minneapolis and City of St. Paul
- Data Name/Contents Camera number, monitor number, camera control command, date and time.
- Data Type Data
- Status Existing
- Constraints Maximum of 32 keypads allowed by existing switcher.

3.9 HARDWARE A19 INCH AND 9 INCH MONITORS@

- Hardware Type	Video monitors
- Functions	Displays CCTV video signals
- Location	TMC Control Room
- Data Name/Contents	Surveillance video
- Data Type	Video
- Status	Existing
- Other	48-19" B/W monitors, 4-19" color monitors, 120- 9" B/W monitors.

3.10 HARDWARE A MODEM/LD-400@

- Hardware Type	Communications data converter.
- Functions	Receives control command messages from video switcher (RS-232) and transmits to communications system.
- Location	TMC communications room.
- Data Name/Contents	Control messages for camera, lens, pan/tilt, washer/wiper.
- Data Type	Data
- Status	Existing

4.1 INTERFACE

	AMERICAN DYNAMICS BLACK BOX
- Connects to ...	Camera, Lens, Pan/Tilt Unit
- Interface location	In field, from 334 cabinet to camera housing.
- Interface Type	Data
- Interface Direction	Both
- Interface Component	27 conductor #18 gauge cable from 334 cabinet to housing.
- Protocol/Standard	Manchester coded control
- Information Type/Content	Device control commands
- Information Direction	Output
- Information Frequency	As operator needs to move camera/devices.

4.2 INTERFACE

- Connects to ...
- Interface location
- Interface Type
- Interface Direction
- Interface Component
- Protocol/Standard
- Information Type/Content
- Information Direction
- Information Frequency

SURVEILLANCE CAMERA

Short/medium range transmitter, video modulator or video multiplexor
In field, from camera housing to 334 cabinet or shelter.
Video
Output
RG-11 triaxial cable
NTSC baseband video
Video
Output
Real time - X frames per second

4.3 INTERFACE

- Connects to ...
- Interface location
- Interface Type
- Interface Direction
- Interface Component
- Information Type/Content
- Information Direction
- Information Frequency

COMMUNICATIONS SYSTEM

TMC Video Switcher
TMC Communications Room
Video and Data
Output (Video from Comm. System to Switcher)
Input (Camera control from Switcher to Comm. System)
Coaxial cable (video), twisted pair (camera control) and Type 170 controller
Video Signal, Camera control signals.
Both
Real time

4.4 INTERFACE

- Connects to ...
- Interface location
- Interface Type
- Interface Direction
- Interface Component
- Protocol/Standard
- Information Type/Content
- Information Direction
- Information Frequency

TMC VIDEO SWITCHER

19" and 9" monitors
Fiber optic equipment
TMC
NTSC baseband video
Output - from switcher to monitors.
RG-59 Coax cable
NTSC baseband video
NTSC baseband video
Video signal goes from Communications system to the 9" monitors, and then is split off and sent back to the video switcher where video signal is then routed to appropriate 19" monitors (only 128) of the system video signals.
Real time - 24 hours/day.

4.5 INTERFACE

- Connects to ...
- Interface location
- Interface Type
- Interface Direction
- Interface Component
- Protocol/Standard
- Information Type/Content

- Information Direction
- Information Frequency

TMC VIDEO SWITCHER

- Switcher Keypad
- TMC
- Data
- Both
- RS-232 cable
- RS-232
- Camera number, monitor number, camera control command.

- Both
- 24 hours per day.

3.2.3 MN/DOT TMC CHANGEABLE MESSAGE SIGN SYSTEM

Baseline Data Collection
Changeable Message Sign System

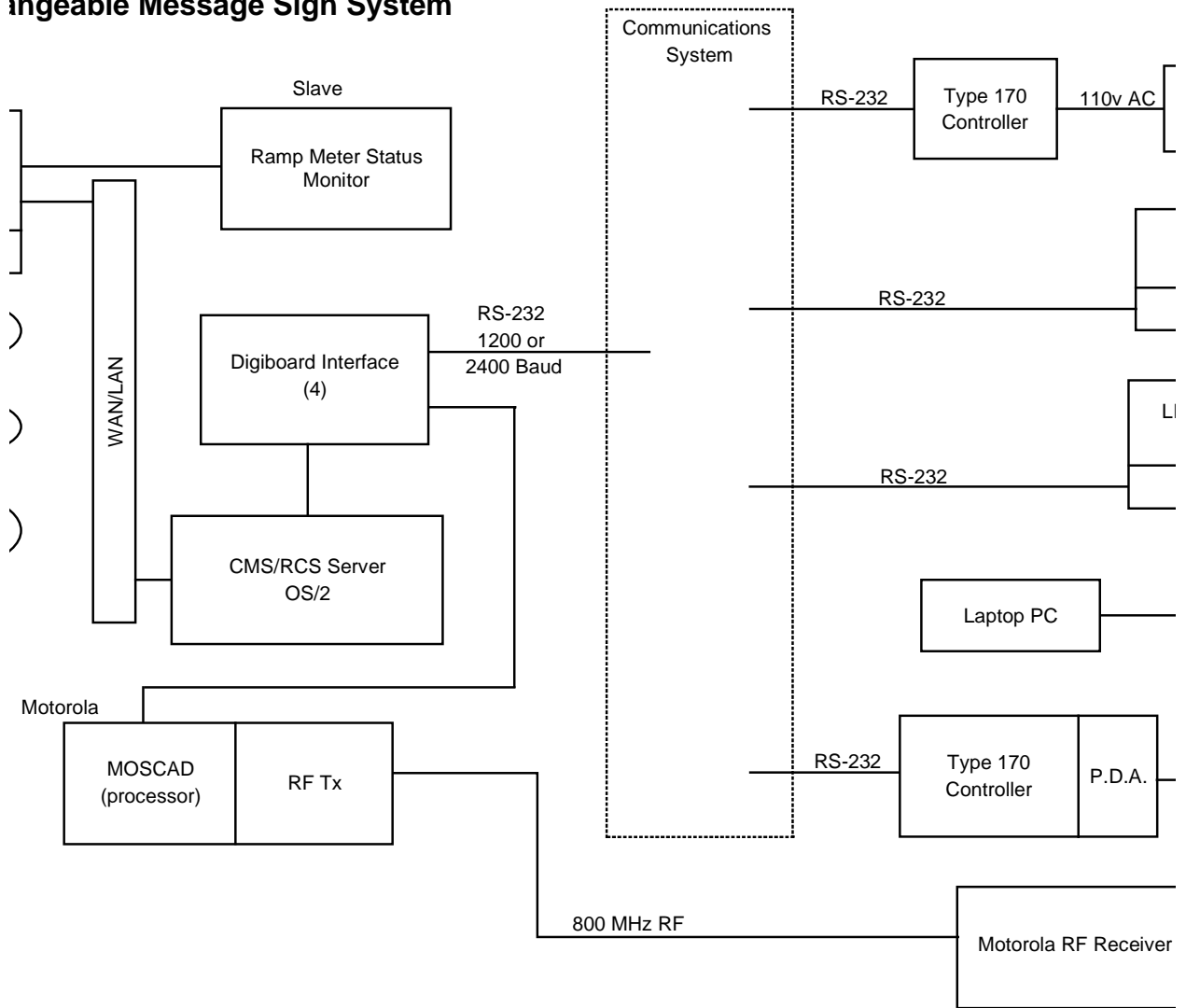

AS-IS DATA COLLECTION TEMPLATE

1.0 AGENCY AMN/DOT TRAFFIC MANAGEMENT CENTER@

- Agency Type Traffic Management
- Agency Functions Manage traffic on Twin City area freeway system.
- Agency Location(s) 1101 4th Avenue South
Minneapolis, MN 55404

2.0 SYSTEM AMN/DOT TMC CHANGEABLE MESSAGE SIGN SYSTEM@

- Date of As-Is Data Collection 2/15/96
- Purpose Display incident information to motorists to prevent accidents, manage congestion.
- Hours of Operation 24 hours/day via either TMC or maintenance.
- Geographic Coverage Twin City Metropolitan Area (TCMA) freeways.
- Contacts Patty Bednarz, Terry Haukom
- Status Existing
- Policies It is a TMC policy that changeable messages signs (CMS) will be used in the event of an incident or other situation (construction, special event, etc) that affects freeway traffic flow to alert motorists of unexpected circumstances.
- Constraints Mn/DOT does not have the entire freeway system instrumented with changeable message signs.
- Block Diagram See attached

2.1 PERSONNEL ATMC OPERATOR@

- Personnel Function Monitor traffic management system devices and utilize to manage traffic congestion, incidents and provide motorist information.
- Quantity 2 operators work during peak period shifts, 1 operator during off-peak shifts.
- Location Traffic Management Center control room.
- Workload High. Each operator has a multitude of devices to monitor, assimilate information and make real time decisions.
- Working hours Each operator works a shift of 3-4 hours.
Weekend shifts are 8 hours.
- Status Existing.

2.2 PERSONNEL ATMC INFORMATION OFFICER@

- Personnel Function Information Officer is responsible for the collection/assimilation of congestion and incident information, and uses this information to determine appropriate messages to disseminate to the motorist via changeable message signs and radio.
- Quantity One Information Officer works for each peak period shift.
- Location Traffic Management Center control room.
- Working hours AM peak period 6AM - 9 AM
PM peak period 3PM - 7 PM
- Status Existing

3.1 HARDWARE ADRUM CHANGEABLE MESSAGE SIGN (CMS)@

- Hardware Type Changeable message sign
- Functions Display messages to motorists traveling on the freeway to alert them of unexpected travel situations.
- Location Mounted on bridges or sign bridges over the freeway traffic lanes throughout the TCMA. See attached location map.
- Data Name/Contents Sign messages
- Data Type Text
- Status Existing at 49 locations in the TCMA.
- Policies
 - Line 1 of the sign is used to describe the type of incident.
 - Line 2 of the sign is used to give the incident location.
 - Line 3 of the sign is used to communicate the impact of the incident.
- Constraints Each text line of a drum type CMS resides on one sign of a hexagon drum, therefore only 5 different messages may be displayed per line, with the 6th side used for a blank message.
- Recommended Improvements Mn/DOT TMC will be installing Light Emitting Diode (LED) signs at locations in the TCMA where more sign message flexibility is required than currently available via Drum CMS.
- Other Drum type CMS have been used extensively in the TCMA because of good durability, reliability, and low maintenance requirements.

3.2 HARDWARE AHOV VANE SIGNS@

- Hardware Type Changeable message sign.
- Functions The HOV Vane sign consists of a standard static freeway type guide sign with a changeable message module located in the bottom center portion of the sign. The changeable message module consists of multiple Avanes@ (vertical sections of sheet metal) with a message on both sides of the sheet metal. An electric motor moves the vanes to display the appropriate message about the status of the HOV reversible lane.
- Location On I-394, T.H. 100 and I-94 near the entrances to the I-394 reversible lane.
- Data Name/Contents Sign message, for example: OPEN, CLOSED, LEFT LANE, or an arrow.
- Data Type Data - via a sign display.
- Status Existing.
- Policies The HOV vane signs are connected to a Type 170 controller and the traffic Management Center communications and control system but the current operation of the sign is via manually controlling the sign in the field by a Mn/DOT Highway Helper.

3.3 HARDWARE ALED VMS@

- Hardware Type Variable Message Sign
- Functions Display messages to motorists traveling on the freeway to alert them of unexpected travel situations.
- Location Mounted on a sign bridge over the freeway traffic lanes over the eastbound lanes of I-494 just west of the I-494/I-94 interchange.
- Data Name/Contents Sign messages
- Data Type Text
- Status Existing

3.4 HARDWARE ALANE CONTROL SIGNAL@

- Hardware Type Changeable message sign.
- Functions Displays a green arrow, yellow arrow, or red flashing X to indicate the condition each lane of traffic.
- Location Mounted over I-94 on approaches to the Lowry Hill tunnel.
- Data Name/Contents Sign display - green or yellow arrow, red X.
- Data Type Data - sign display.
- Status Existing
- Policies Used only during incidents or non-typical congestion in the I-94 Lowry Hill tunnel area.

3.5 HARDWARE ALAPTOP PC@

- Hardware Type Portable Computer
- Functions Allows maintenance or other personnel to operate the LED Variable message sign from an access point near the sign.
- Location Mobile
- Data Name/Contents Sign control software.
- Data Type Data - sign control
- Status Existing

3.6 HARDWARE ATYPE 170 CONTROLLER@

- Hardware Type Traffic Signal Controller
- Functions Receives sign message requests from the TMC central computer and controls variable message signs and lane control signals.
- Location In field cabinet near lane control signals or within the
- Data Name/Contents
 - 1) Changeable Message Sign messages
 - 2) Changeable Message Sign status
 - 3) Lane Control Signal Status
- Data Type Data
- Status Existing

3.7 HARDWARE ACMS/RCS PC & MONITOR@

- Hardware Type Computer
- Functions Display status of traffic management devices. Accept device control commands and forward to CMS/RCS PC Server.
- Location TMC Control Room
- Data Name/Contents
 - 1) Changeable Message Sign messages
 - 2) Changeable Message Sign status
 - 3) Lane Control Signal Status
 - 4) HAR sign status
 - 5) Ramp Control Signal status
- Data Type Data
- Status Existing
- Contact Ron Dahl

3.8 HARDWARE ACMS/RCS SERVER@

- Hardware Type Computer
- Functions
 - 1) Poll 170 controllers
 - 2) Receive ramp meter status and loop detector data (volume/occupancy) from Type 170's.
 - 3) Write loop detector data to database.
 - 4) Compute ramp meter rates using loop detector data (30 second loop detector station volume and occupancy).
 - 5) Send control commands to changeable messages signs.
 - 6) Receives verify messages from changeable message signs.
 - 7) Generate congestion status map.
- Location TMC - Computer Room
- Data Name/Contents
 - 1) Changeable Message Sign messages
 - 2) Changeable Message Sign status
 - 3) Lane Control Signal Status
 - 4) HAR sign status
 - 5) Ramp Control Signal status
 - 6) Loop detector volume/occupancy data
- Data Type Data
- Status Existing
- Contact Ron Dahl

3.9 HARDWARE AMOSCAD/RF TRANSMITTER@

- Hardware Type Processor
- Functions Transmits message to HAR sign.
- Location TMC
- Data Name/Contents Sign address and On/Off command.
- Data Type Data
- Status Existing

3.10 HARDWARE AMOTOROLA RF RECEIVER@

- Hardware Type Radio receiver
- Functions
 - Receives transmission from MOSCAD/Transmitter and turns on/off HAR sign.
 - Transmits confirmation messages back to MOSCAD including: Tamper Alarm, Power Off Alarm, Sign Active Verification
- Location Mount on HAR sign in field.
- Data Name/Contents Receives sign address and On/Off command transmission from MOSCAD/Transmitter.
- Data Type Data
- Status Existing

3.11 HARDWARE AHAR SIGNS@

- Hardware Type Static Message Sign with flashing lights.
- Functions Display flashing beacons to motorists traveling on the freeway to alert motorists to tune to KBEM radio to hear broadcast of information about traffic incident on roadway they are approaching.
- Location Mounted on breakaway U-channel posts on shoulder along side of roadway.
- Data Name/Contents Static sign displays message ATune to Traffic Radio 88.5 FM when flashing@. Lights alternate flashing to create a Awig-wag@ strobe effect.
- Data Type Text, flashing lights.
- Status Existing
- Policies TMC will turn on wig wag flashers only when major incident occurs which necessitates live continuous broadcast of traffic information on KBEM.
- Constraints Sign legend cannot be changed.

3.12 HARDWARE ADIGIBOARD INTERFACE@

- Hardware Type Router
- Functions Allows a PC to interface to multiple (up to 256) RS-232 communication ports.
- Location TMC Computer Room
- Data Name/Contents
 - 1) Changeable Message Sign messages
 - 2) Changeable Message Sign status
 - 3) Lane Control Signal Status
 - 4) Ramp Control Signal status
 - 5) Loop detector volume/occupancy data
- Data Type Data
- Status Existing

4.1	INTERFACE	Type 170 Controller
- Connects to ...		TMC Communications System
- Interface location		Roadside
- Interface Type		Data
- Interface Direction		Both
- Interface Component		Twisted pair copper wire cable
- Protocol/Standard		RS-232
- Information Type/Content		1)Changeable Message Sign messages 2) Changeable Message Sign status 3) Lane Control Signal Status 4) Ramp Control Signal status 5) Loop detector volume/occupancy data
- Information Direction		Both
- Information Frequency		Every 30 seconds
4.2	INTERFACE	CMS/RCS SERVER
- Connects to ...		TMC Communications System
- Interface location		TMC
- Interface Type		Data
- Interface Direction		Both
- Interface Component		Twisted pair cooper wire cable
- Information Type/Content		1)Changeable Message Sign messages 2) Changeable Message Sign status 3) Lane Control Signal Status 4) HAR sign status 5) Ramp Control Signal status 6) Loop detector volume/occupancy data
- Information Direction		Both
- Information Frequency		Continuous
4.3	INTERFACE	MOSCAD/TRANSMITTER
- Connects to ...		Motorola RF Receiver
- Interface location		TMC to/from field
- Interface Type		Data
- Interface Direction		Both
- Interface Component		800 MHZ Radio Frequency
- Information Type/Content		Commands to turn HAR sign on/off. Confirmation messages back to MOSCAD including: Tamper Alarm, Power Off Alarm, Sign Active Verification.
- Information Direction		Both

3.2.4 MN/DOT TMC COMMUNICATIONS SYSTEM

Baseline Data Collection
Communication System Configuration #1

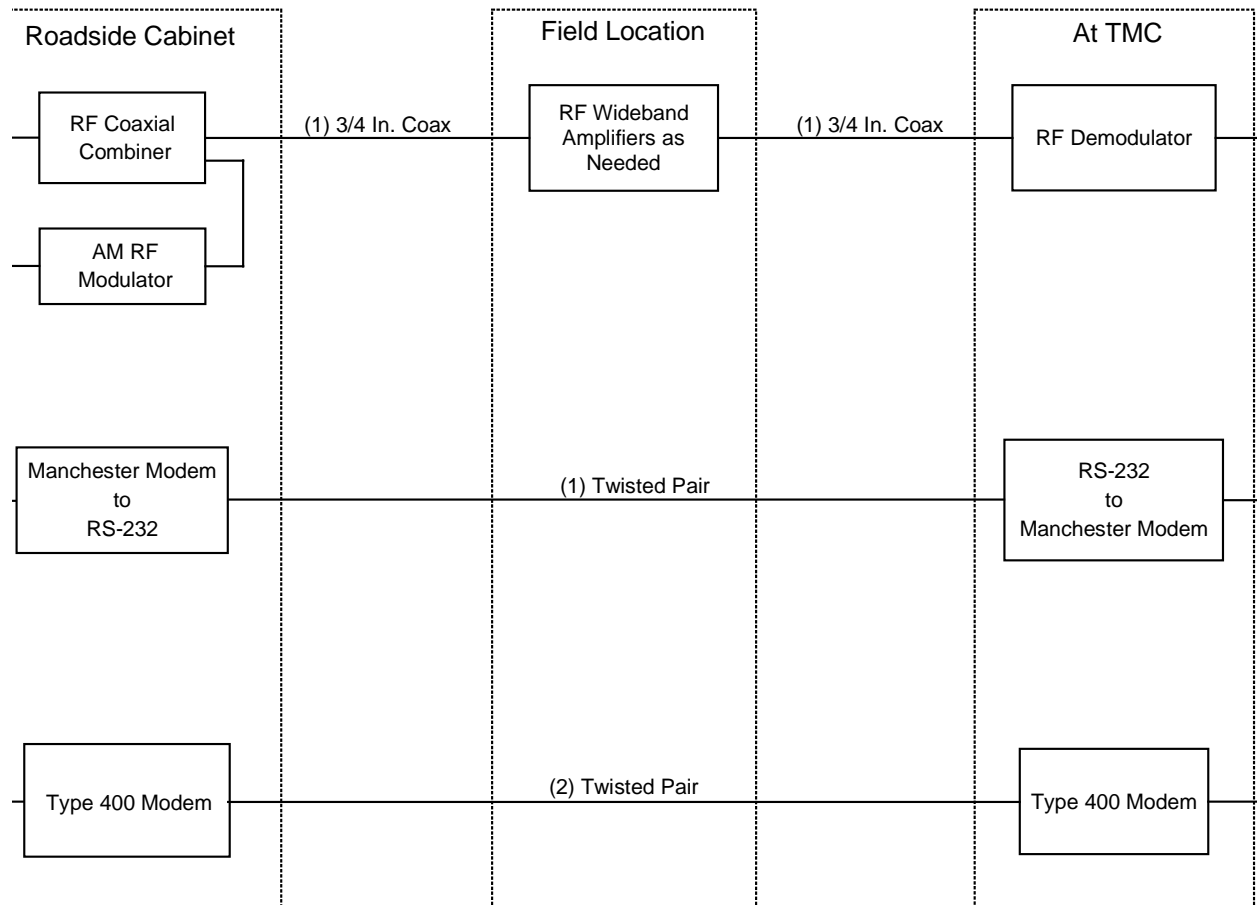

Baseline Data Collection
Communication System Configuration #2

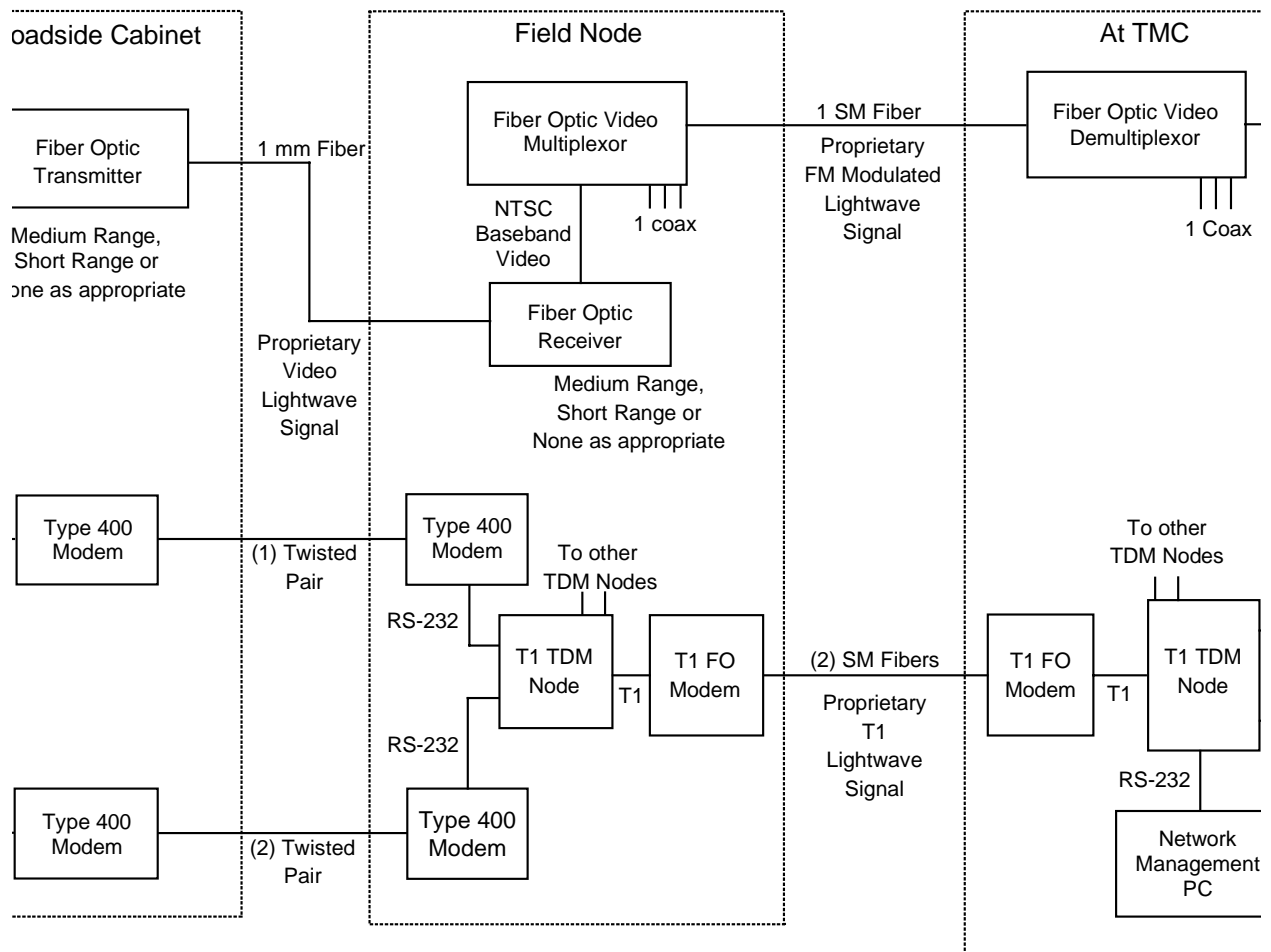

s Baseline Data Collection
Communication System Configuration #3

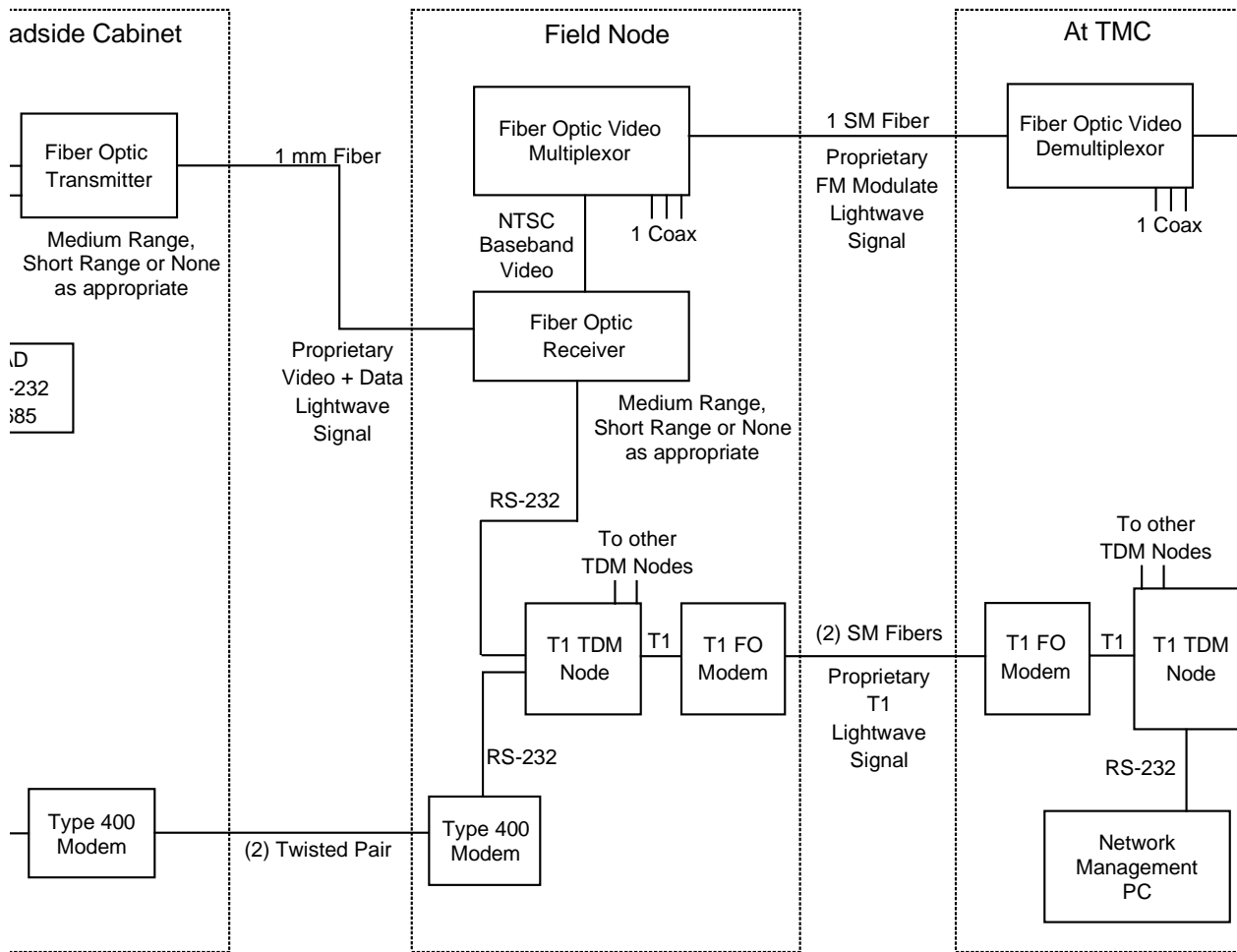

Baseline Data Collection
Communication System Configuration #4

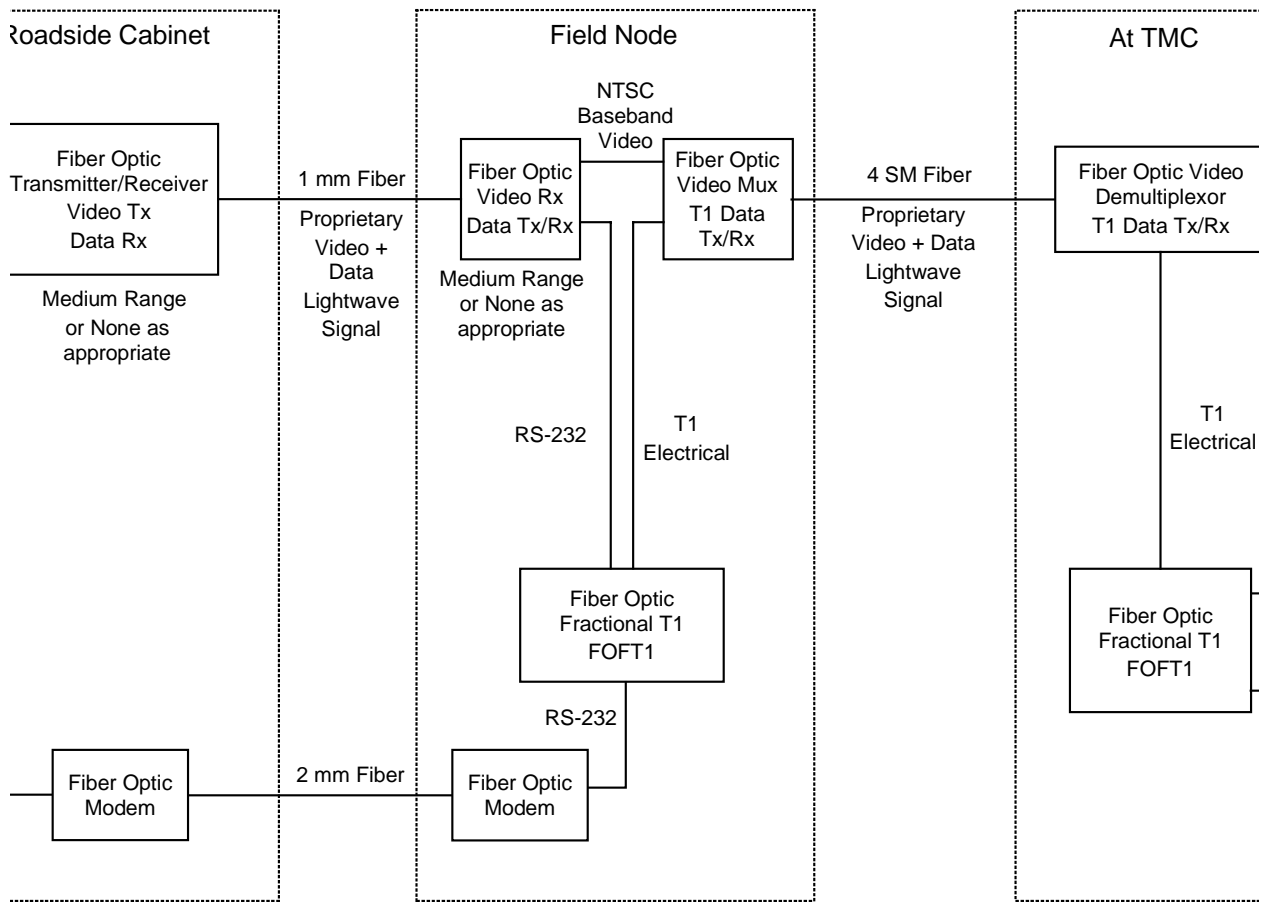

AS-IS DATA COLLECTION TEMPLATE

1.0 AGENCY AMn/DOT TRAFFIC MANAGEMENT CENTER@

- Agency Type Traffic Management
- Agency Functions Manage traffic on Twin City area freeway system.
- Agency Location(s) 1101 4th Avenue South
Minneapolis, MN 55404

2.0 SYSTEM AMN/DOT TMC COMMUNICATIONS SYSTEM@

- Date of As-Is Data Collection 2/15/96
- Purpose Provide communications between TMC and all traffic management devices in field.
- Hours of Operation 24 hours per day
- Geographic Coverage Twin Cities Metro Area.
- Contacts Rich Lau, Patty Bednarz, Terry Haukom
- Status Existing
- Block Diagram See attached

3.1 HARDWARE ATYPE 400 MODEM@

- Hardware Type Modem
- Functions Transmits and receives data
- Location In 170 controllers, in TMC Communications room, in TMC shelters.
- Data Name/Contents
 - 1) Changeable Message Sign control commands
 - 2) Changeable Message Sign status
 - 3) Lane Control Signal Status and control commands
 - 4) Ramp Control Signal control commands and status
 - 5) Loop detector volume/occupancy data
- Data Type Data
- Status Existing
- Constraints 1200 or 2400 baud rate with existing modems.

3.2 HARDWARE AMANCHESTER MODEM@

- Hardware Type Modem
- Functions Transmits and receives data
- Location In field and in TMC Communications room.
- Data Name/Contents Camera device control commands such as pan left, pan right, tilt up, tilt down, zoom in, zoom out, washer on, washer off, wiper on, wiper off and focus.
- Data Type Data
- Status Existing
- Other 9600 baud

3.3 HARDWARE AAM RF MODULATOR@

- Hardware Type Video transmission device
- Functions Converts NTSC baseband video signal to AM RF signal with other camera signals and transmits onto coaxial cable into communication system.
- Location Field cabinet
- Data Name/Contents Surveillance video signal
- Data Type Video
- Status Existing
- Other Gerold and Scientific Atlanta modulators

3.4 HARDWARE ARF WIDEBAND AMPLIFIER@

- Hardware Type Video transmission device
- Functions Receives incoming modulated video signal on coaxial cable from one direction and rebroadcasts stronger signal on coaxial cable. This device is used when there is a need to transmit video signal over long distances.
- Location Field - in cabinets along right of way.
- Data Name/Contents Broadband RF modulated video signal.
- Data Type Video
- Status Existing

3.5 HARDWARE ARF DEMODULATOR@

- Hardware Type Video transmission device
- Functions Receives incoming modulated video signal on coaxial cable, demodulates signal into NTSC baseband video and transmits to video switcher.
- Location TMC Communications room
- Data Name/Contents Broadband RF modulated video signal
- Data Type Video
- Status Existing

3.6 HARDWARE AFIBER OPTIC TRANSMITTER@

- Hardware Type Video transmission device - transmitter
- Functions Converts NTSC baseband video signal to FM analog signal and transmits onto multi-mode fiber optic cable into Communication System.
- Location 334 Cabinet near Camera pole.
- Data Name/Contents Surveillance video signal
- Data Type Video
- Status Existing

3.7 HARDWARE AFIBER OPTIC RECEIVER@

- Hardware Type Video transmission device - receiver
- Functions Receives analog video signal and transmits to fiber optic multiplexor for re-transmission on single mode fiber optic cable.
- Location TMC communication shelters.
- Data Name/Contents Analog video signal
- Data Type Video
- Status Existing

3.8 HARDWARE AFIBER OPTIC VIDEO MULTIPLEXOR@

- Hardware Type Video transmission device
- Functions Receives multiple video signals, multiplexes them into one FM modulated analog signal, and transmits to TMC on single mode fiber optic cable.
- Location TMC communication shelters
- Data Name/Contents Analog video signal
- Data Type Video
- Status Existing
- Constraints Up to 12 (18,24) video signals may be multiplexed into one signal for transmission on single mode fiber optic cable. 20 mile maximum transmission range.
- Other Foundation Instruments, Fiberlign, Catel, Fiber Options. Transmits on single mode fiber at 1300 nm wavelength.

3.9 HARDWARE AFIBER OPTIC VIDEO DEMULTIPLEXOR@

- Hardware Type Video transmission device
- Functions Receives multiplexed analog video signal, demultiplexes (separates) into several NTSC baseband video signals, and transmits these on coax cable to video switcher.
- Location TMC communications room
- Data Name/Contents Analog video signal.
- Data Type Video
- Status Existing

3.10 HARDWARE AT1 TDM NODE@

- Hardware Type Data transmission device - Time Division Multiplexor
- Functions Accepts data from multiple sources/modems or other TDM-s and multiplexes into a data stream onto single mode fiber optic cable and transmits to other TDM-s in the field or at the TMC.
- Location TMC communications shelters
- Data Name/Contents
 - 1) Changeable Message Sign control commands
 - 2) Changeable Message Sign status
 - 3) Lane Control Signal Status and control commands
 - 4) Ramp Control Signal control commands and status
 - 5) Loop detector volume/occupancy data
 - 6) Camera device control commands such as pan left, pan right, tilt up, tilt down, zoom in, zoom out, washer on, washer off, wiper on, wiper off, camera Id.
- Data Type Data
- Status Existing

3.11 HARDWARE ANETWORK MANAGEMENT PC@

- Hardware Type Computer
- Functions Monitors the fiber optic data communications system for errors. Maintains network synchronization. Also maintains network configuration for primary and backup communications links and automatically re-routes communications if failure occurs.
- Location TMC computer room
- Data Name/Contents Node Id-s, network configuration, transmission errors, device errors and communication re-route.
- Data Type Data
- Status Existing

3.12 HARDWARE AFIBER OPTIC FRACTIONAL T1 (FOFT1)@

- Hardware Type Data transmission device
- Functions Receives data and multiplexes into one signal for transmission to the TMC.
- Location TMC communications shelters
- Data Name/Contents
 - 1) Changeable Message Sign control commands
 - 2) Changeable Message Sign status
 - 3) Lane Control Signal Status and control commands
 - 4) Ramp Control Signal control commands and status
 - 5) Loop detector volume/occupancy data
 - 6) Camera device control commands such as pan left, pan right, tilt up, tilt down, zoom in, zoom out, washer on, washer off, wiper on, wiper off, camera Id.
- Data Type Data
- Status Existing - being installed in current projects.

3.2.5 MN/DOT TMC HIGHWAY HELPER AVL SYSTEM

Baseline Data Collection
Highway Helper AVL System

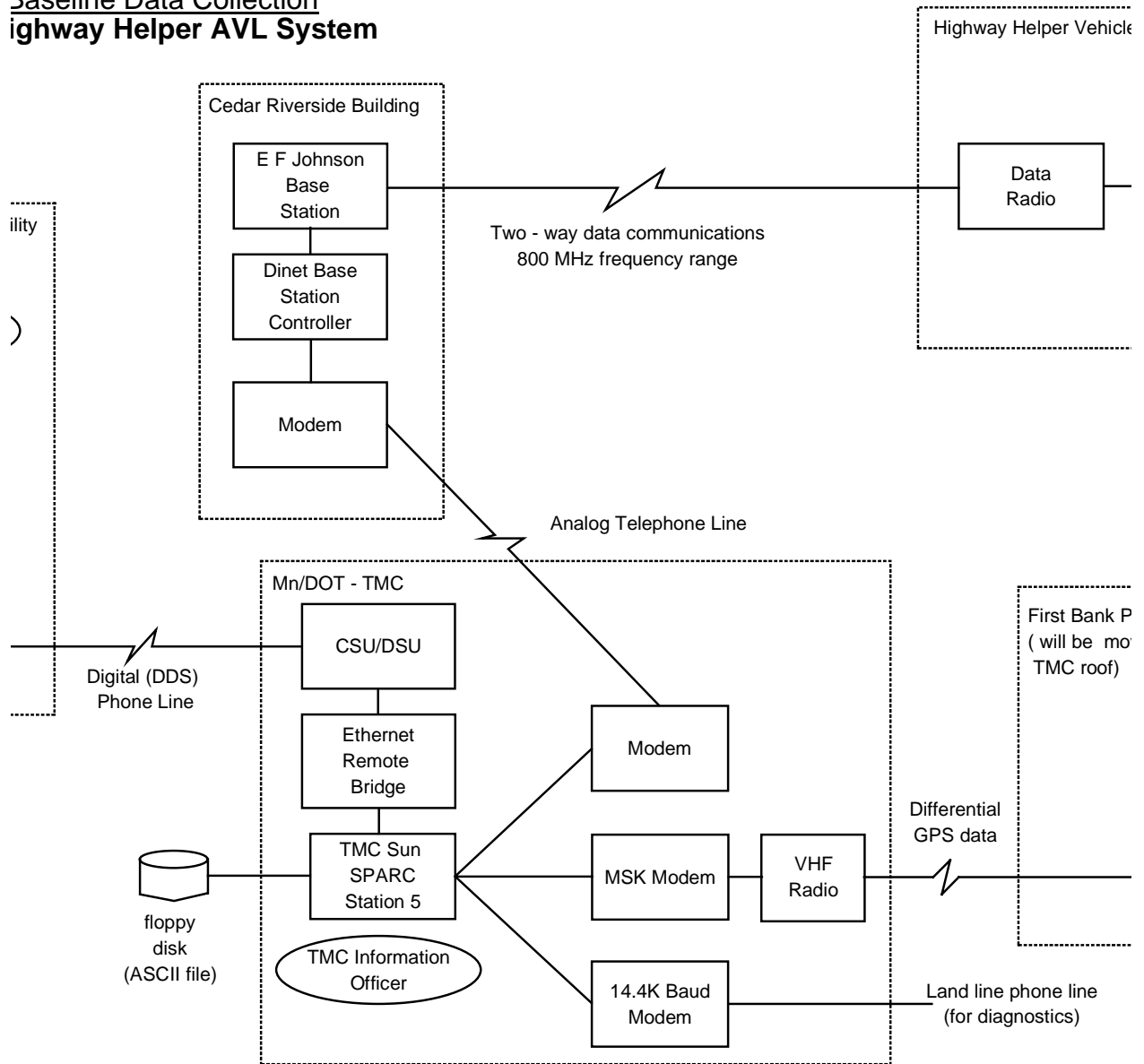

AS-IS DATA COLLECTION TEMPLATE

1.0 AGENCY AMN/DOT TRAFFIC MANAGEMENT CENTER@

- Agency Type Freeway Operations section of Mn/DOT Metro Division
- Agency Functions Manage traffic on Twin City area freeway system.
- Agency Location(s) 1101 4th Avenue South, Minneapolis, MN 55404

2.0 SYSTEM HIGHWAY HELPER AUTOMATIC VEHICLE LOCATION SYSTEM@

- Date of As-Is Data Collection 4/25/96
- Purpose
 - 1) Track the location and status of Highway Helpers to enable Traffic Management Center dispatch personnel (Information Officers) to direct the most appropriate response vehicle to an incident.
 - 2) Provide a quicker response to stalled vehicles or accidents on the freeway system.
 - 3) Enhance communications between the Highway Helpers, TMC Information Officers and the State Patrol dispatchers.
 - 4) Eliminate data entry of incident information.
 - 5) Test AVL and GPS technology for Mn/DOT and the State Patrol.
- Hours of Operation M - F (5 AM - 7:30 PM)
Saturday & Sunday (9 AM - 9 PM)
- Geographic Coverage AVL system will communicate with HH vehicles within the Twin Cities Metropolitan area.
Highway Helpers (HH) cover six freeway routes in Twin Cities:
 - 1) I-94 from I-35E to Radio Drive (C.R. 13) and T.H. 3 from I-94 to Concord St.
 - 2) I-94 from T.H. 280 to I-35E and I-35E from I-94 to Little Canada Road.
 - 3) I-94 from 49th Ave. to T.H. 280.
 - 4) I-94 from T.H. 169 to I-694 and I-694 from I-94 to I-35W.
 - 5) I-35W from Hennepin Ave. to I-494.
 - 6) I-494 from East Bush Lake Road to 24th Ave. and I-35W from I-494 to T.H. 13.
- Contacts Sue Groth 341-7227
- Status Existing
- Constraints System is capable of tracking up to 250 vehicles.
Standalone system - not integrated with other control room equipment.
- Issues
 - 1) Mapping data - Etak. Some roadway data is incorrect.
 - 2) Differential corrections. (Not working as of 07/21/96)
 - 3) Vehicle tracking in certain key locations is poor -

experiencing some problems with vehicles transmitting data/locations when moving in certain geographic areas such as I-35E north of St. Paul and I-494.

4) Conversion of ASCII data to Highway Helper database.

5) System occasionally locks up.

6) Future enhancements.

- Recommended Improvements

Differential GPS receiver equipment will be installed on roof of TMC in near future to provide differential location corrections.

- Block Diagram

See attached

- Typical Operational Scenario

At the beginning of each shift the Highway Helpers sign into the system through the MDT located in their vehicle.

They enter their name, route assignment, shift hours, beginning mileage and cellular phone number. While the HH are patrolling their routes their position and status is displayed at the TMC control room and the State Patrol dispatch center. A HH status is defined as Available, En route to an incident scene, On scene of an accident, On scene of a stall, Transporting a motorist, or Out of service. As their status changes the corresponding color of their vehicle icon is changed on the MetroView workstation. When the HH arrives at a stalled vehicle they change their status to On scene at a stall by pushing the appropriate status key on the MDT. When their work is completed they push the Completed assignment key and immediately enter information pertaining to the stop. This information includes the roadway identification, mile point, direction of travel, license plate of the vehicle assisted, what service was provided (e.g. tire change, gas, traffic control, push, etc.), which lane the vehicle was in, and if the State Patrol or a tow truck was called. The system automatically logs the time and corresponding latitude and longitude with the incident record. When completed with the logging process the HH pushes the Available status key and begins to patrol the route again. The TMC operator can also send a text message to the HH while they are out of their vehicle instructing them to attend another incident that was detected. The MDT will hold the message so it can be read when they return to their vehicle.

- Other

Total system costs approximately \$130,000

2.1 PERSONNEL ATMC INFORMATION OFFICER@

- Personnel Function
Information Officer is responsible for identifying and monitoring incidents and coordinating the dissemination of information to various incident responders/dispatchers and news media.
Information Officer dispatches the appropriate Highway Helper vehicle to an incident based on the HH location, status, ability to arrive to incident scene quickly, and response of the other emergency responders like the State Patrol.
- Quantity
One Information Officer works for each peak period shift. On
- Location
Traffic Management Center control room.
- Workload
Very high
- Working hours
AM peak period 6AM - 9 AM
PM peak period 3PM - 7 PM
Information Officer is working and available to support control room operations during off peak (9AM - 3PM).
- Status
Existing

2.2 PERSONNEL A HIGHWAY HELPER@

- Personnel Function
Patrol selected freeway routes and minimize congestion by quickly responding to stalls and accidents and removing these incidents from the freeway.
- Quantity
14 Highway Helpers, cover 6-7 routes.
A minimum of 5 HH are working during a peak period, typically six working during peak period to cover all six routes.
One HH works during weekend shifts.
- Location
Dispatched from TMC.
- Working hours
AM peak period 5:30 AM - 11:30 AM
PM peak period 1:00 PM - 7:00 PM
- Status
Existing

2.3 PERSONNEL ASTATE PATROL DISPATCHER@

- Personnel Function Monitors the HH locations to aid in determination of dispatching of State Patrol Troopers to incidents.
 - 1) Receive calls
 - 2) Dispatch trooper to respond to calls
 - 3) Notify Public Safety Answering Points of incidents.
 - 4) Coordinate incident management activity with TMC, Mn/DOT Maintenance, Police, Fire, Tow companies, CVO inspection, Hazmat, etc.
- Quantity 16 full time dispatchers, 2 are supervisors.
- Location State Patrol Dispatch Facility - Waters Edge, 1500 County Road B2, Roseville
- Workload Very high
- Working hours 24 hours/day, 365 days/year.
Have a minimum of 4 dispatchers on duty during AM and PM peak periods, i.e. 6-9 AM and 3 - 7 PM.
Currently run dispatchers on a fixed schedule, i.e. each dispatcher has a fixed shift that they work such as 3PM - 11 PM.
- Status Existing
- Contact Major Ron Bolin

2.4 PERSONNEL ASTATE PATROL TROOPER - SARGENT CARTRIGHT@

- Personnel Function This one Trooper has the AVL vehicle location equipment in his vehicle and is trying it out as a pilot project.
- Quantity One
- Location Twin Cities Metro Area
- Status Existing

3.1 HARDWARE ATMC SUN SPARCstation 5@

- Hardware Type Computer
- Functions
 - 1) Display location and status of Highway Helper vehicles and one Patrol vehicle on a GIS map.
 - 2) Send text messages to HH MDT.
 - 3) Stores incident record when HH completes incident report.
 - 4) Automatically log time and HH vehicle's longitude and latitude with an incident record.
- Location TMC Control Room
- Data Name/Contents Metro area GIS map with street names and attributes. Map area being viewed. Vehicle status data such as:
 - 1)Vehicle Location
 - 2)Vehicle Speed
 - 3) Location of nearest cross street

- 4) HH cellular phone number
- 5) HH hours of work
- 6) HH route number

Highway Helper status data such as:

- 1) On scene accident
- 2) On scene stall
- 3) On scene debris
- 4) On scene other
- 5) Busy
- 6) En route
- 7) Available
- 8) Out of service
- 9) Transporting a motorist
- 10) Emergency Distress
- 11) Last time location was updated.

Incident data from the HH is stored here, i.e. When the HH work is completed at an assist, they push the Acompleted assignment@key and immediately enter information pertaining to the stop. This information includes:

- 1) Roadway identification
- 2) Mile point
- 3) Direction of travel
- 4) License plate of the vehicle assisted
- 5) What service was provided (e.g. tire change, gas, traffic control, push,)
- 6) Which lane the vehicle was in
- 7) If the State Patrol or a tow truck was called
- 8) Incident ID number.

The system automatically logs the time and corresponding latitude and longitude with the incident record.

- Data Type
- Status
- Other

Data

Existing

SPARC 5, 70 MHZ, 32 Mb memory, TGX graphics accelerator, Internal 1 gigabyte disk drive, 1 External QIC tape drive, 1 External modem 325 for data, 1 External modem for support, 1 Set Remote Ethernet Equipment

3.1.1 SOFTWARE ASUN SPARCstation OPERATING SYSTEM@

- Software Type Operating System
- Software Standards Unix
- Status Existing
- Recommended Improvements This may be upgrade to a Windows NT operating system in the future.

3.1.2 SOFTWARE AMETROVIEW@

- Software Type Application - AVL software.
- Functions
 - 1) Displays the location and status of Highway Helper vehicles and one State Patrol vehicle. As HH status changes the corresponding color of their vehicle icon is changed on the MetroView workstation (i.e. green = available, yellow = en route, blue = on scene, gray = off).
 - 2) Send and receive messages to Highway Helper vehicles.
 - 3) Playback a Highway Helper unit-s previous day activities.
 - 4) Add landmarks.
 - 5) Creates incidents log for each incident that a HH responded to.
 - 6) User can display two map views using split screen function or user can display a map view on one half of the screen and a window showing HH status on the other side of screen.Software has a Awindows@ look and feel and pull down menus are used to send messages while viewing map and perform other functions.
- Status Existing - System went online in fall of 1995.
- Constraints / Restrictions TMC can go into map and add landmarks, but MetroView will not allow TMC to change map attributes.
- Other System designed and installed by Ball Systems. Etak map was converted into ArcInfo format and then was converted into MapInfo which is used by the MetroView software.

3.2 HARDWARE AMSP SUN SPARCstation 5@

- Hardware Type Computer
- Functions Display location of Highway Helper vehicles and one Patrol vehicle on a GIS map.
- Location Mn State Patrol Dispatch Room - Waters Edge
- Data Name/Contents Metro area GIS map with street names and attributes.
Map area being viewed.
Vehicle status data such as:
 - 1) Location
 - 2) Speed
 - 3) Location of nearest cross street
 - 4) HH cellular phone number
 - 5) HH hours of work
 - 6) HH route numberHighway Helper status data such as:
 - 1) On scene accident
 - 2) On scene stall
 - 3) On scene debris
 - 4) On scene other
 - 5) Busy
 - 6) En route
 - 7) Available
 - 8) Out of service
 - 9) Transporting a motorist
 - 10)Emergency Distress
 - 11)Last time location was updated.
- Data Type Data
- Status Existing
- Constraints Standalone system, not integrated into the State Patrol's dispatch console so the Patrol dispatcher has to leave dispatch station and walk over to this monitor to use system. Therefore it may not be used too much.
- Recommended Improvements Future design of control room would have this integrated into dispatcher console.
- Other SPARC 5, 70 MHZ
16 Mb memory
TGX graphics accelerator
Internal 500 Mb disk drive
1 Set Remote Ethernet Equipment

3.2.1 SOFTWARE ASUN SPARCstation OPERATING SYSTEM@

- Software Type Operating System
- Software Standards Unix
- Status Existing
- Recommended Improvements This may be upgrade to a Windows NT operating system in the future.

3.2.2 SOFTWARE AMETROVIEW@

- Software Type Application
- Functions Displays the location and status of Highway Helper vehicles and one State Patrol vehicle.
- Status Existing
- Constraints / Restrictions Proprietary software

3.3 HARDWARE ADINET MOBILE DATA TERMINAL@

- Hardware Type Data terminal and GPS receiver.
- Functions Contains a GPS receiver which receives signals from GPS satellites and computes the vehicle's location. MDT used to receive text messages from TMC. MDT used to report status of HH vehicle and transmit incident information. Status options are:
 - 1) On scene accident
 - 2) On scene stall
 - 3) On scene debris
 - 4) On scene other
 - 5) Busy
 - 6) En route
 - 7) Available
 - 8) Out of service
 - 9) Transporting a motorist
 - 10) Emergency Distress
 - 11) Log On
 - 12) Incident summaryAs the Highway Helper pushes any of the above buttons, the message is sent to the TMC along with the vehicle's latitude and longitude, as calculated by the MDT. HH types up a short summary of incident and transmits to TMC when completed with assistance. Incident data collected is:
 - 1) Method of Detection (Highway Helper, TMC, Mn/DOT Radio, other)
 - 2) Incident Type (Accident, Stall, Debris, other)
 - 3) Roadway Identification
 - 4) Direction (N, S, E, W)
 - 5) Lanes involved (Right/Left shoulder, Lane 1-5, Median, Auxiliary Lane, Entrance Ramp, Exit Ramp, HOV lane, Off Roadway)
 - 6) Mile point
 - 7) Arrival Time
 - 8) Departure Time
 - 9) Assistance Type (Coolant, Battery, Telephone, Directions, Fuel, Tag, Mechanical, other, Push, Ride, Tire Change, Remove Debris, Traffic Control)
 - 10) Vehicle License
 - 11) Other Assistance Required (Ambulance, City Police, Fire Truck, State Patrol, Tow Truck, other)
 - 12) Assistance Notify Time
 - 13) Did HH communicate with State Patrol troopers on the radio (Y/N).

- Location In all Highway Helper vehicles and in one State Patrol vehicle.
- Data Name/Contents Latitude and Longitude of vehicle is sent to TMC whenever a message is sent, or every 1 minute/1 mile of travel, whichever occurs first.
Type of assistance requested and provided including:
1) The roadway identification, mile point, direction of travel.
2) License plate of the vehicle assisted.
3) What service was provided (e.g. tire change, gas, traffic control, push)
4) Which lane the vehicle was in
5) If the State Patrol or a tow truck was called.
- Data Type Data
- Status Existing
- Constraints Location accuracy is with 200 - 300 feet as calculated by MDT. Accuracy is improved to be within 3 meters using differential correction.
Display screen is Liquid Crystal Display of two lines, approximately 60 -80 characters per line. A message sent between TMC and HH must be less than 180 characters
- Recommended Improvements TMC would like to receive an acknowledgment when the HH receives the a message sent from TMC Information Officer.
- Other Dinet Data Mate 3100 MDT
Includes a Motorola Oncore GPS receiver to provide position information.
Ball Systems custom-configured the layout of the MDT user interface screen for Mn/DOT.

3.3.1 SOFTWARE ASOFTWARE #3@

- Software Type MDT firmware
- Software Standards Proprietary

3.4 HARDWARE ADATA RADIO@

- Hardware Type Radio
- Functions Sends/receives messages to/from TMC.
- Location In all Highway Helper vehicles and in one State Patrol vehicle.
- Data Name/Contents Text messages.
HH latitude and longitude as calculated by MDT.
HH vehicle status.
HH entry commands.
- Data Type Data
- Status Existing
- Constraints Proprietary data communications system.
- Other Manufactured by EF Johnson

3.5 HARDWARE AEF JOHNSON BASE STATION@

- Hardware Type Radio Base station
- Location Roof of Cedar Riverside Building in Minneapolis.
- Data Type Data
- Status Existing
- Constraints Proprietary data communications system
- Other Manufactured by EF Johnson

3.6 HARDWARE ADINET BASE STATION CONTROLLER@

- Hardware Type Telecommunications device - base station.
- Functions Converts data message from RF to phone lines.
Performs some error checking of MDT operation, i.e. if the unit is the mode of on the scene of an incident and the HH makes an illogical entry (such as en route), the system will not accept the entry.
- Location Roof of Cedar Riverside Building in Minneapolis.
- Data Type Data
- Status Existing

4.2	INTERFACE	TMC SUN SPARCstation 5
- Connects to ...		Dinet Base Station Controller
- Interface Type		Data
- Interface Direction		Both
- Interface Component		Analog phone line
- Information Type/Content		HH and Patrol vehicle location and status. Text messages to/from Highway Helpers.
- Information Direction		Both
- Information Frequency		Once per minute at a minimum, or as messages are sent from HH to TMC or a TMC polls HH locations.
- Information Standards		Vehicle latitude and longitude
4.3	INTERFACE	TMC SUN SPARCstation 5
- Connects to ...		Differential GPS Receiver
- Interface location		TMC
- Interface Type		Data
- Interface Direction		Input - from GPS receiver to SPARCstation 5
- Information Type/Content		Differential GPS data
- Information Direction		Input - from GPS receiver to SPARCstation 5
- Information Standards		Latitude and longitude
4.4	INTERFACE	TMC SUN SPARCstation 5
- Connects to ...		14.4K Baud Modem
- Interface location		TMC
- Interface Type		Data
- Interface Direction		Both
- Interface Component		Modem w/ phone line
- Information Type/Content		System diagnostics data
- Information Direction		Both
4.5	INTERFACE	E F JOHNSON BASE STATION
- Connects to ...		Data Radio
- Interface Type		Data
- Interface Direction		Both
- Interface Component		RF - 800 MHZ frequency
- Information Type/Content		Text messages, HH vehicle location data
- Information Direction		Both
- Information Frequency		Once per minute at a minimum, or as messages are sent from HH to TMC or a TMC polls HH locations.

APPENDIX A

As-Is Agency Reports Pre-Survey Candidate Systems List

PRE-SURVEY CANDIDATE SYSTEMS

Traffic Signal Control Systems

- City of St. Paul Computran traffic signal control system
- City of St. Paul traffic signal intersection hardware (field equipment)
- City of Minneapolis Fortran traffic signal control system
- Mn/DOT Metro Division/District traffic office closed loop traffic signal system(s)
- County closed loop traffic signal systems (Hennepin, Ramsey, etc.)
- City closed loop traffic signal systems
- Video detection/control of signal system (T.H. 65 & 53rd, Lyndale and Franklin Ave)
- Pre-emption of traffic signals for emergency vehicles (EVP)
- Pre-emption of traffic signal at fire stations
- Pre-emption of traffic signals at railroad crossings (20 locations in Metro area)
- Minneapolis AUSCI operational test

Freeway Management System

- Mn/DOT TMC ramp meter system
- Mn/DOT TMC video surveillance system
- Mn/DOT TMC CMS control system
- KBEM radio broadcast system
- Mn/DOT TMC cable TV information system - (Triple Vision system)
- Mn/DOT Metro Division/District portable changeable message signs
- TMC traffic history database (volume and occupancy data)
- TMC incident log database
- U of M Autoscope incident detection system
- Genesis operational test
- Trilogy operational test
- Mn/DOT workzone traffic management system operational test

Transit Management Systems

- MCTO "Trapeze" scheduling/planning system (creates bus/driver schedules)
- MCTO "radio" system (computer assisted radio system, 7 channels)
- MCTO automatic passenger counters (on some buses)
- MCTO electronic fare collection boxes (on all buses)
- MCTO TIC BusLine system (voice responses system, customer service system)
- MCTO customer service system for route/schedule planning (live telephone operators)
- MCTO transportation section (provides construction information to MCTO)
- MCTO bus stop database (contains the attributes of each bus stop)
- MCTO Police crime/incident tracking system
- MCTO Opticom emitters (EVP on 80 buses)
- MCTO speed light system (ramp meter pre-emption on selected ramps)
- MCTO Route-O-Matic system - vectors around incidents and congestion
- Metropolitan Council Rideshare system (Mn dial-a-ride)
- MCTO funded paratransit systems
- Metropolitan Council Metro Mobility passenger registration system
- Metropolitan Council Metro Mobility passenger reservation system
- U of M transit management
- Southwest Transit
- Minnesota Valley Transit
- Plymouth Metrolink
- School bus dispatch systems

Incident Management Program

- Mn/DOT TMC Highway Helper program (including AVL system)
- Private tow contracts
- U of M police incident management
- St. Paul DIVERT operational test

Electronic Fare Payment Systems

- City of Minneapolis Parking fare collection (smart card)
- City of Minneapolis electronic parking meter maid system
- Smart Darts operational test

PRE-SURVEY CANDIDATE SYSTEMS (CONTINUED)

Electronic Toll Collection Systems

- Toll road proposals (5 proposals in MN)
- Congestion Pricing Study
- Mileage based tax study

Multi modal Traveler Information Systems

- Travlink operational test

Administrative Systems

- Mn/DOT Electrical Services maintenance management system
- Mn/DOT Electrical Service gopher state one-call access system
- Mn/DOT TIS
- Mn/DOT automatic traffic recorder system
- Mn/DOT ISTEPA management systems
- Mn/DOT CVO administrative systems
- DPS CVO administrative systems
- City of Minneapolis sign database

Other Information Systems

- Airline flight arrival/departure information - NW
- Airport rental car kiosk - Hertz
- MN Office of Tourism travel information center kiosks
- Mn/DOT TMC road weather information system access
- Mn/DOT Metro Division weather information access
- Mn/DOT Aeronautics weather information system
- Mn/DOT statewide road weather information telephone information
- Mn/DOT Pavement Condition and Weather Reporting System - future
- Internal distribution system Distribution of TMC loop data via the Internet
- RWIS - Mn/DOT future Road/Weather Information System

Emergency Response Systems

- Motorist call box system
- Mobile Data Terminals (MDT) in all State Patrol cars
- Laptop PC's in State Patrol cars to replace MDT's - pilot project in 1996
- Emergency 911 log system at State Patrol
- State Patrol information desk
- State Patrol South St. Paul information desk
- State Patrol access to drivers license information. via 911 center
- Mn/DOT Mayday operational test
- Demand response dispatch systems - numerous standalone systems

Parking Management Systems

- Metropolitan airports commission parking management
- City of Minneapolis parking management systems
- U of M parking management
- St. Paul Advanced Parking Information System operational test

Miscellaneous

- Mn/DOT portable traffic management system
- City of Minneapolis police special event management
- City of St. Paul special event management
- U of M special event management
- Mn/DOT pilot differential GPS broadcast base station
- Mn/DOT maintenance vehicle AVL
- Mn/DOT Metro Division/District maintenance dispatch
- Hennepin County Medical Center emergency vehicle dispatch
- MN Pollution Control Agency air quality monitoring sites
- Met. Council Forecasting models - uses data from Mn/DOT TIS database
- U of M traffic management system proposal

Interagency Systems

- ICTM - Integrated Corridor Traffic Management System operational test
(includes Autoscope)
- ARCTIC - operational test in Virginia, MN

PRE-SURVEY CANDIDATE SYSTEMS (CONTINUED)

CVO Systems

- List of systems from MN Guidestar
- CVO call-in number
- State Patrol toll free Information number

Construction Information/Notification Systems

- Gopher State One Call system for utility locations
- Mn/DOT construction information dissemination
- Counties' systems (Hennepin County)
- Counties' systems (Ramsey County)
- City system (Minneapolis)
- City system (St. Paul)
- Utilities' systems

Communications Systems

- Mn/DOT TMC Fiber optic data communications system
- Mn/DOT Microwave Communication System
- Mn/DOT T1 system
- Mn/DOT Wide Area Network
- MNET (STARS)
- Voice radio - State Patrol, Mn/DOT Maintenance, DNR
- 800 MHZ Trunked Radio system (Metro area)
- Internet Communications
- Traffic Signal Interconnect systems
- RBDS - Radio Broadcast Data Systems
- Mn/DOT Video Conferencing

APPENDIX B

As-Is Agency Reports Data Collection Guide