

Simple Techniques for Estimating the Shear Strength and the Coefficient of Permeability of Unsaturated Soils

By
Sai K. Vanapalli
Lakehead University, Thunder Bay
Canada



Unsaturated Soil Engineering: Applications in Pavements

Maplewood, Minnesota: 5th August, 2002

Today's Presentation

- **Establish:** Need for unsaturated soil mechanics in pavement designs
- **Theory:** Simple extensions of classical soil mechanics
- **Simple Techniques/Procedures for Interpreting the Engineering Behavior of Unsaturated Soils:** Using conventional soil mechanics lab facilities

Pavement Design Procedures

- **Present /conventional procedures:** Experience and Empirical procedures
- **Rational procedure:** Take into account of the influence of wet-dry and freeze-thaw cycles (**Use principles of unsaturated soil mechanics**)
- **Rational Approach:** Use stress state variable approach (**Two stress state variables: Net normal stress, $(\sigma - u_a)$ and matric suction, $(u_a - u_w)$**)
- **Key engineering properties:** Shear strength and the Coefficient of permeability

Unsaturated Soils Testing

Shear Strength of Unsaturated Soils

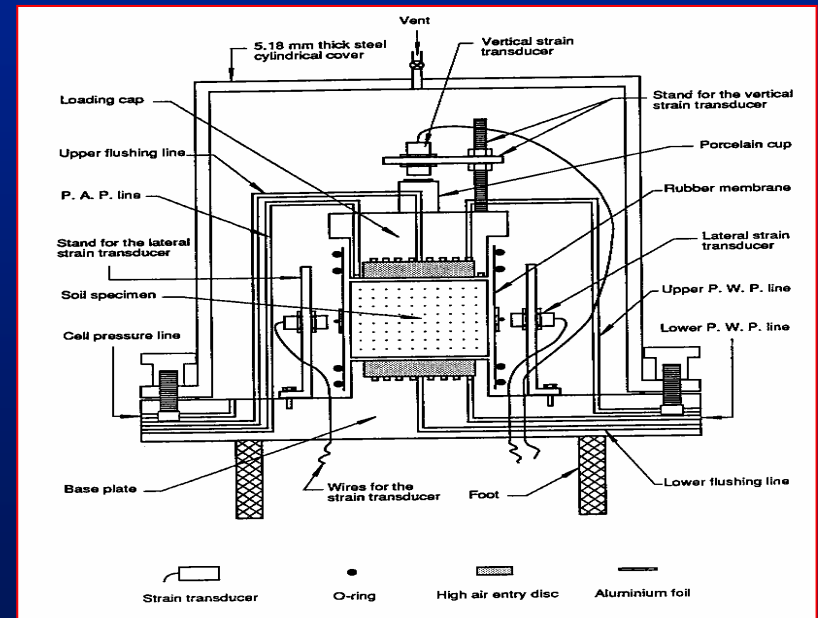
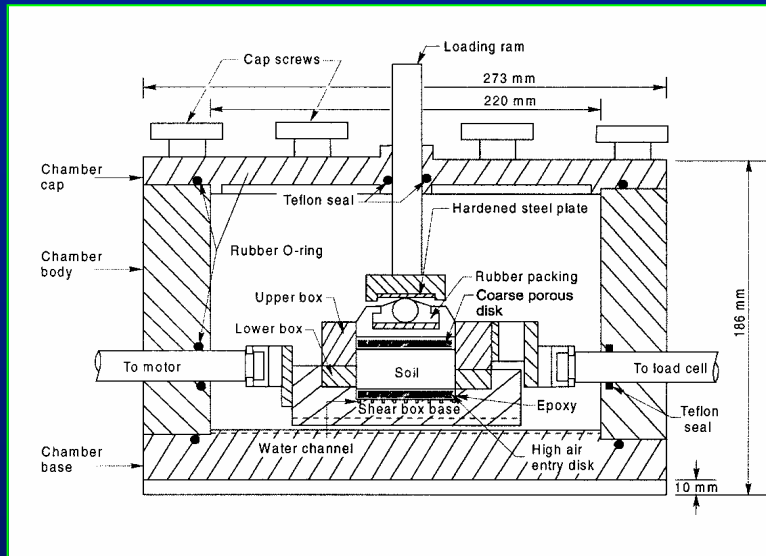

Coefficient of Permeability of Unsaturated Soils

Unsaturated Soils Testing

- Need extensive laboratory facilities
- Time consuming and expensive
- **Need simple techniques:** for practical applications such as the design of pavements
- **Focus:** Estimating the shear strength and the coefficient of permeability of unsaturated soils
- **Key information:** Soil-Water Characteristic Curve (SWCC)

Soil-Water Characteristic Curve (SWCC)

A useful tool in the interpretation of USM

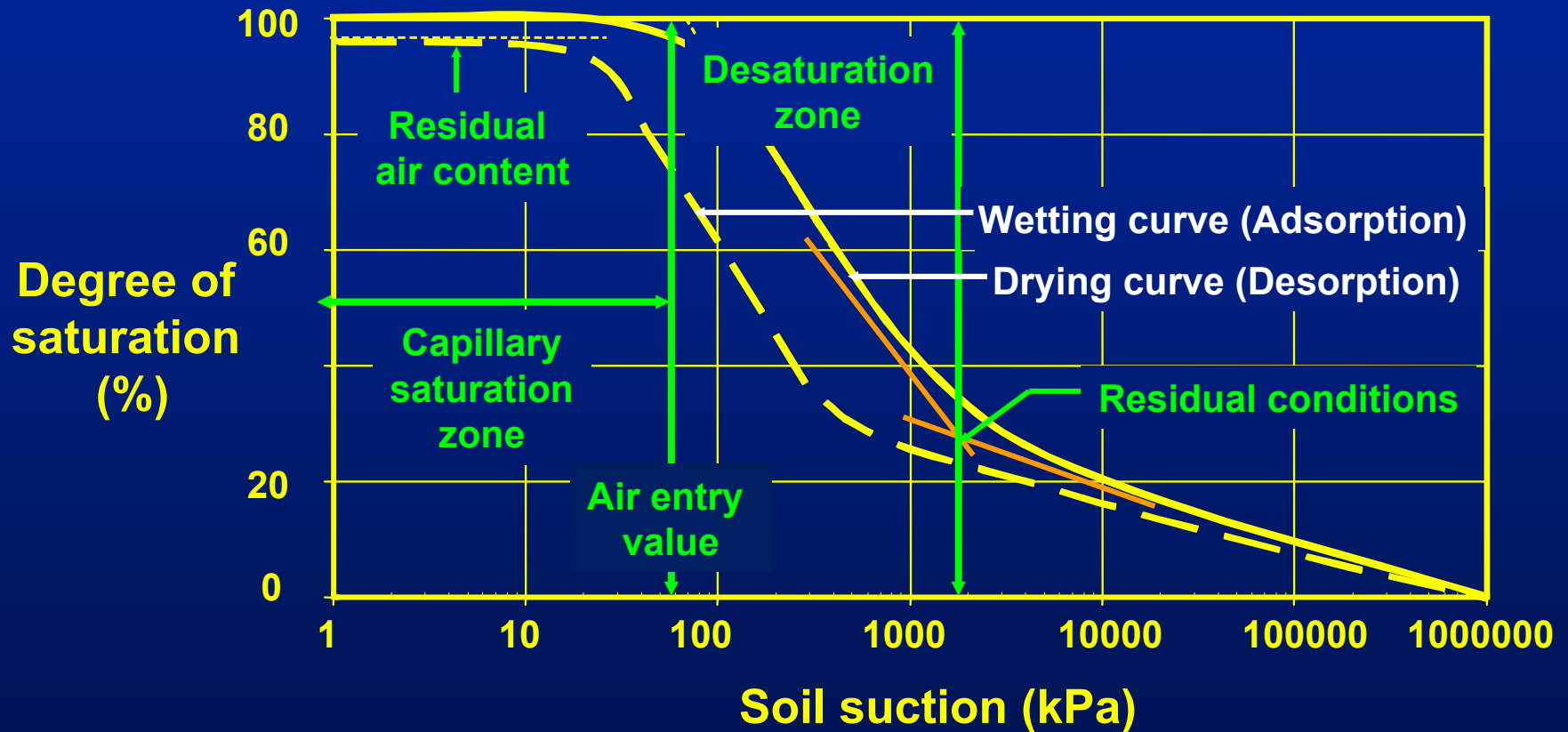

Measurement of the SWCC

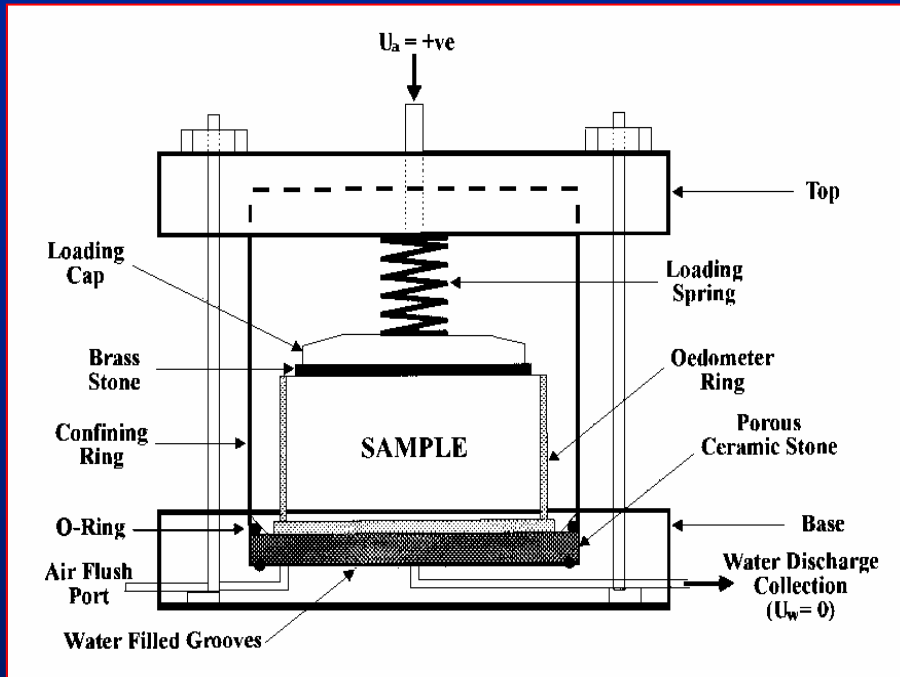

Tempe Cell/ Pressure plate
(liquid phase flow)



Osmotic Desiccators
(Vapor phase flow)

Small - Scale Beckman Centrifuge J6 – HC

**(Simple and fast technique
for SWCC measurement)**



Saturated Soil Specimens and Saturated Ceramic Cylinders in the Specimen Holders



Soil Specimen Holders Ready to Centrifuge



Indian Head Till Test Results

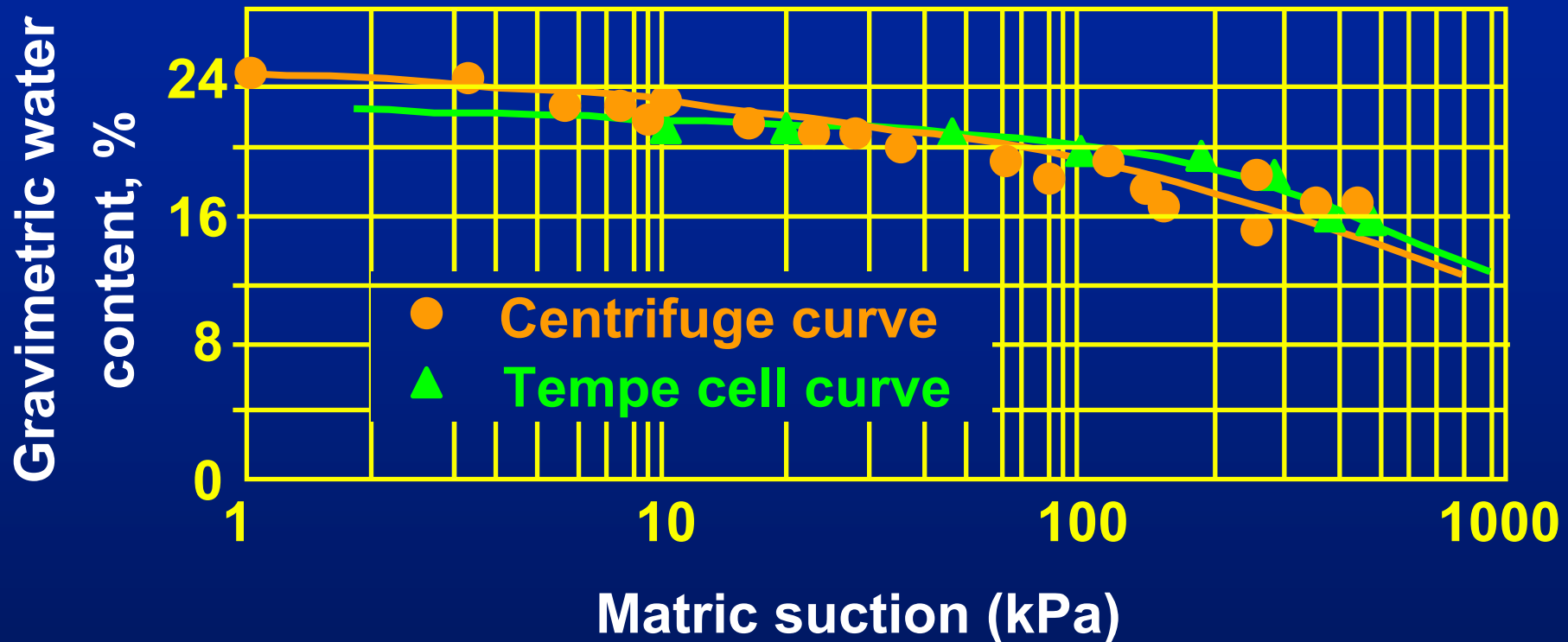

Centrifuge test, $\rho_d = 1.77 \text{ Mg/m}^3$, $w = 19.2\%$

Tempe cell test, $\rho_d = 1.77 \text{ Mg/m}^3$, $w = 19\%$

Time Required to Obtain a SWCC

Test method used	Silt	Indian Head Till	Regina Clay
Centrifuge time (days)	0.5	1	2
Tempe cell time (days)	14	42	112

Pore Water Distribution

Shear strength and Volume Change: Related to the interphase contact area controlling stress transfer

Coefficient of permeability : Related to the continuity and tortuosity of liquid phase

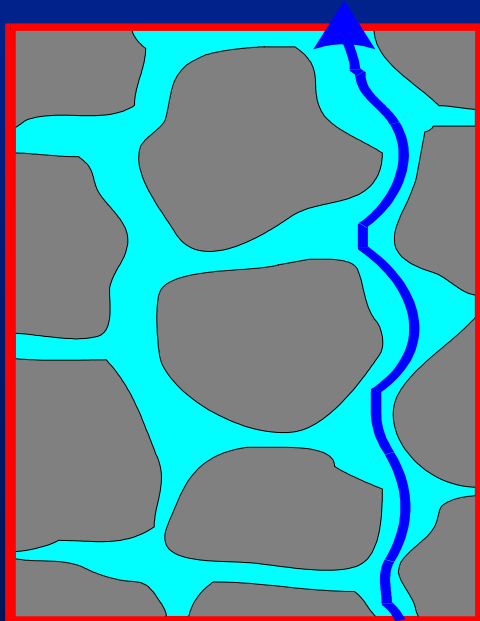

$$S = 100$$

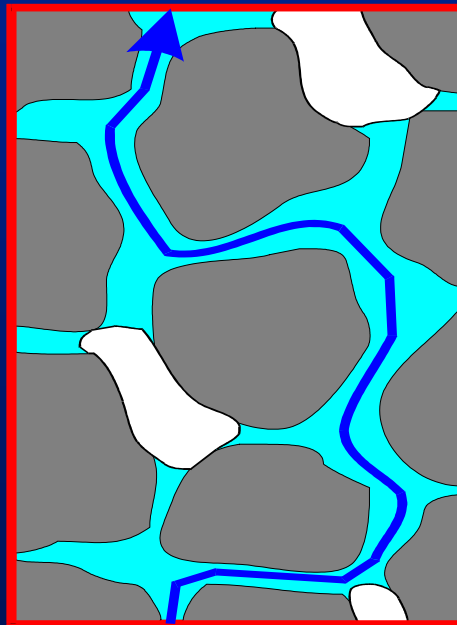

$$1 > S > S_r$$

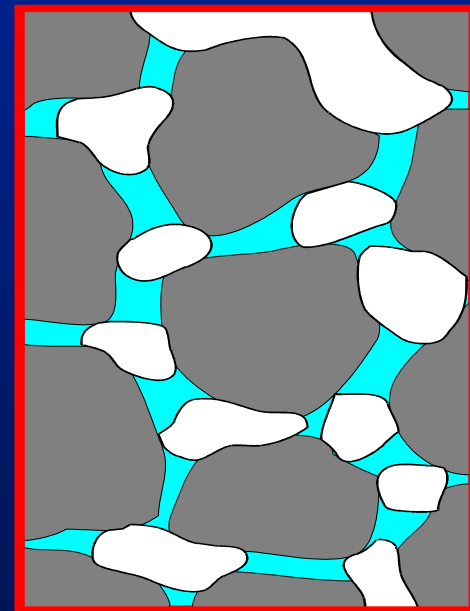

$$S = S_r$$

Shear Strength of Unsaturated Soils

Relationship Between SWCC and Shear Strength versus Matric Suction

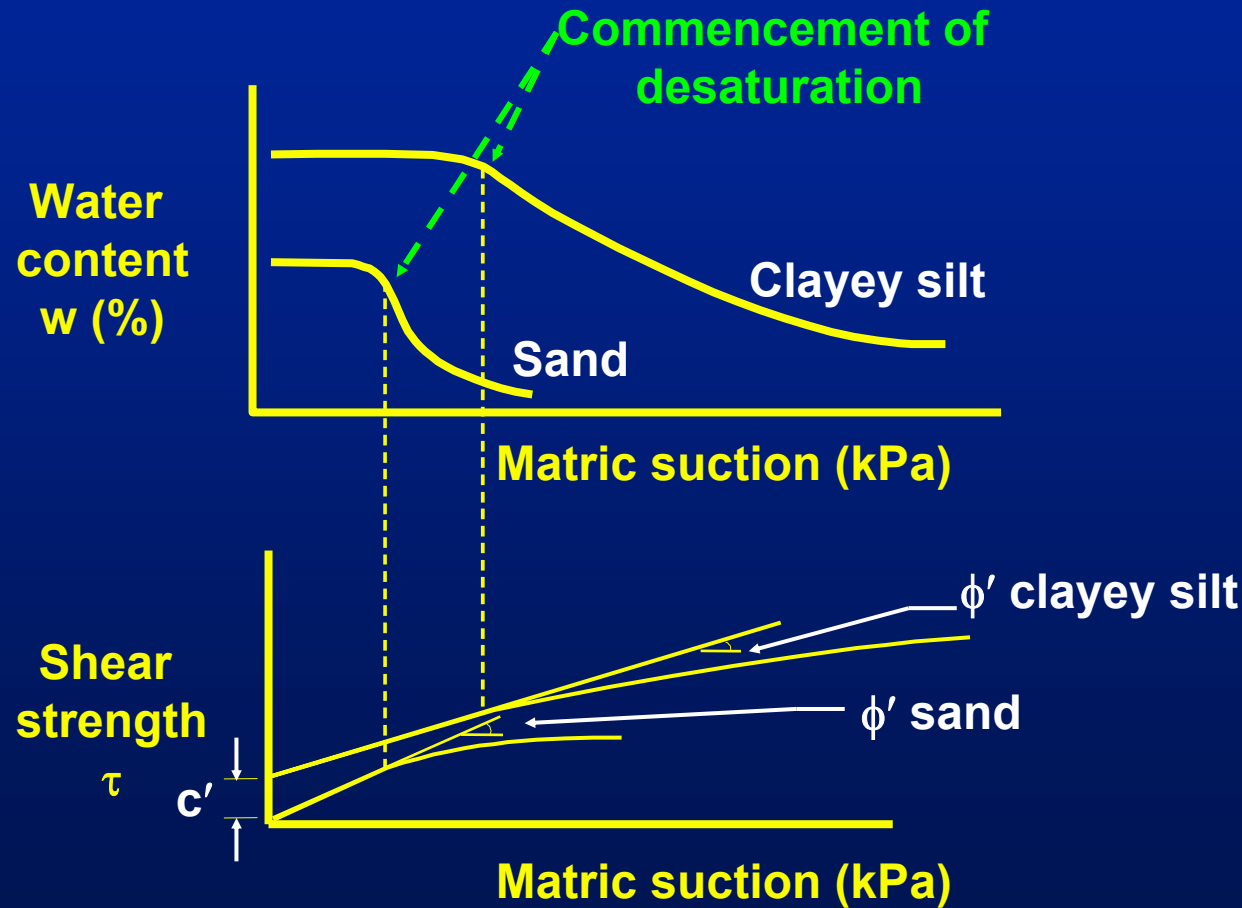

Unsaturated Soils Shear Strength Prediction (Vanapalli et al. 1996)

$$\tau = c' + (\sigma_n - u_a) \tan \phi' + [\Theta(\psi)]^\kappa (u_a - u_w) \tan \phi'$$

where: $\Theta(\psi) = \theta(\psi)/\theta_s$

$\theta(\psi)$ = volumetric water content at any suction

κ = fitting parameter to account for non-linearity between area and volume representation of the amount of water contributing to the shear strength

Comparison between Predicted and Measured Shear Strengths (Vanapalli and Fredlund, 2000)

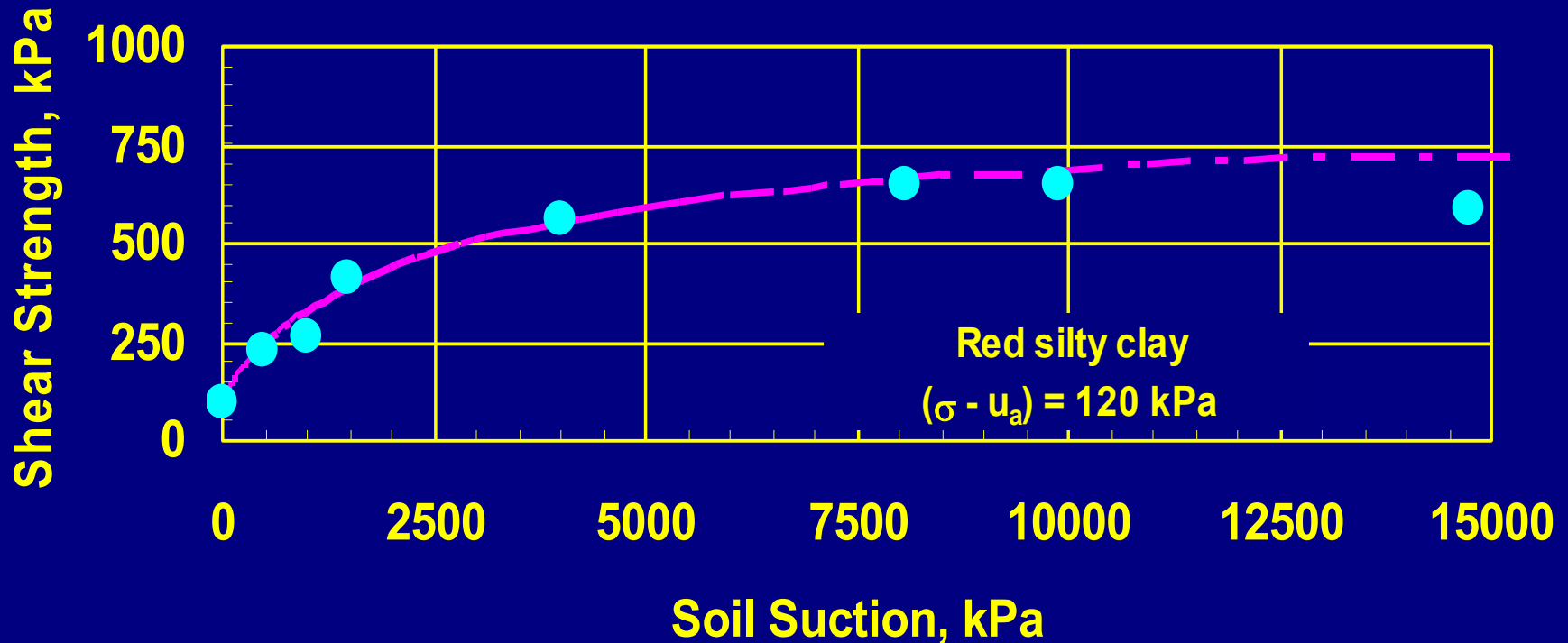

Relationship between κ vs I_p (Vanapalli and Fredlund, 2000)

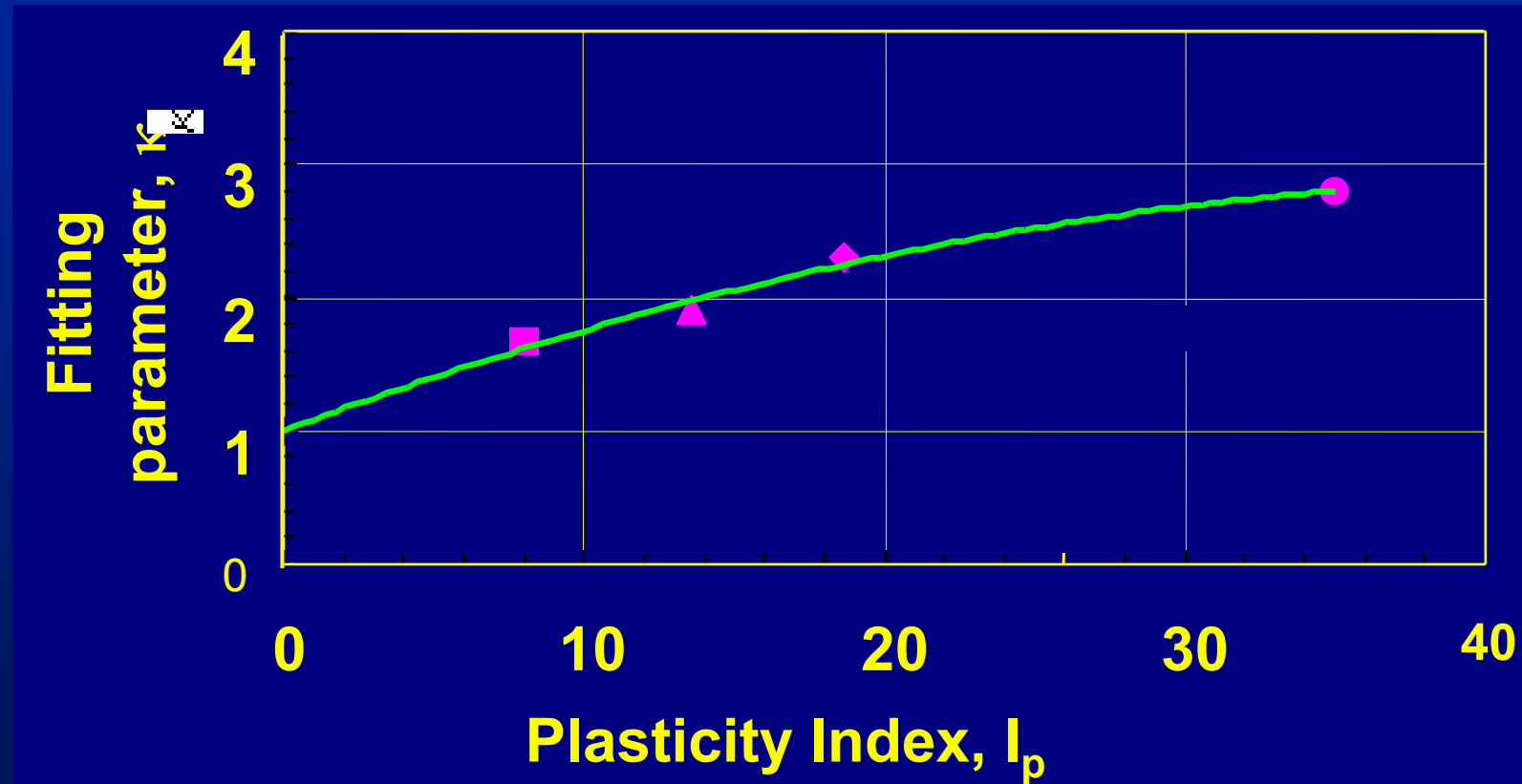

- Useful relationship to estimate the fitting parameter value, κ

Pre-shear and Post-shear SWCC data from the Triaxial Shear Test Results on Dhanauri clay specimens (derived from Satija 1978)

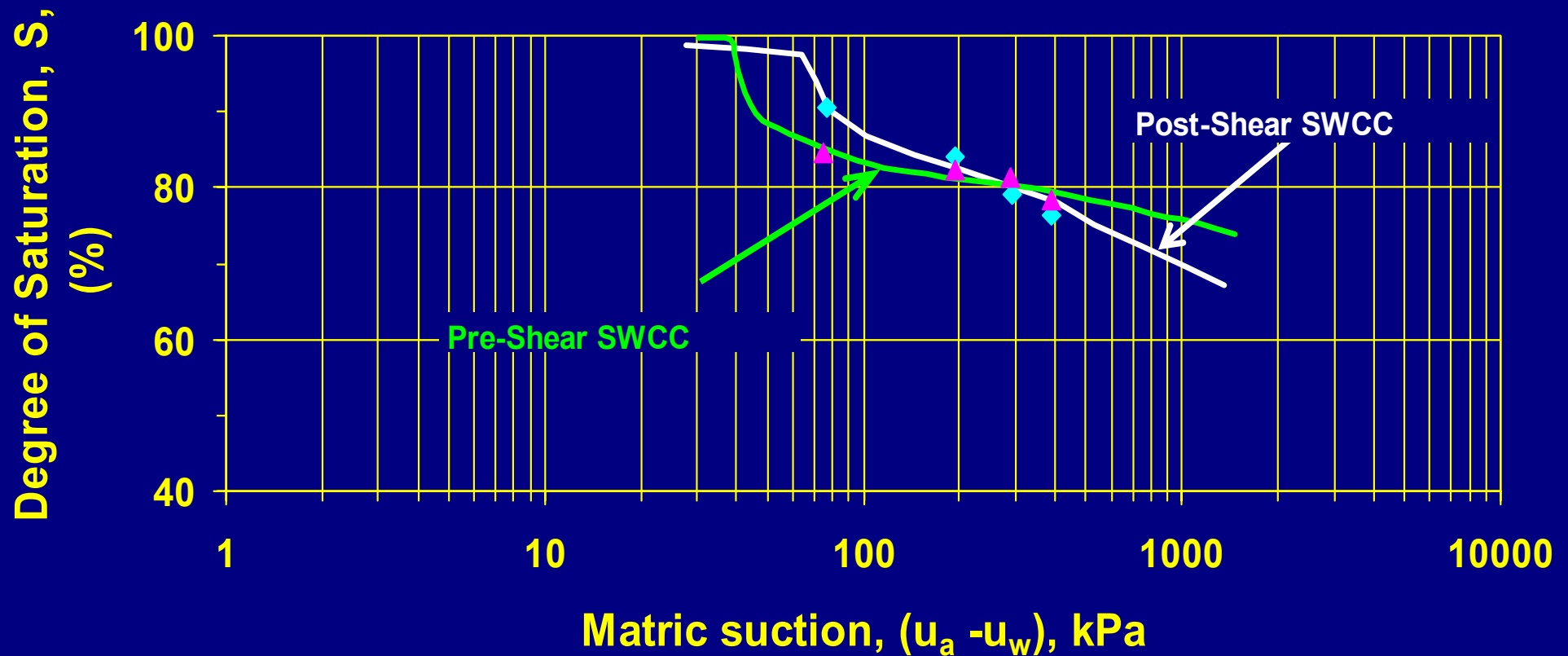

Measured and Predicted Shear Strength of Dhanauri clay for Low Suction Range (Using Pre and Post-shear SWCC)

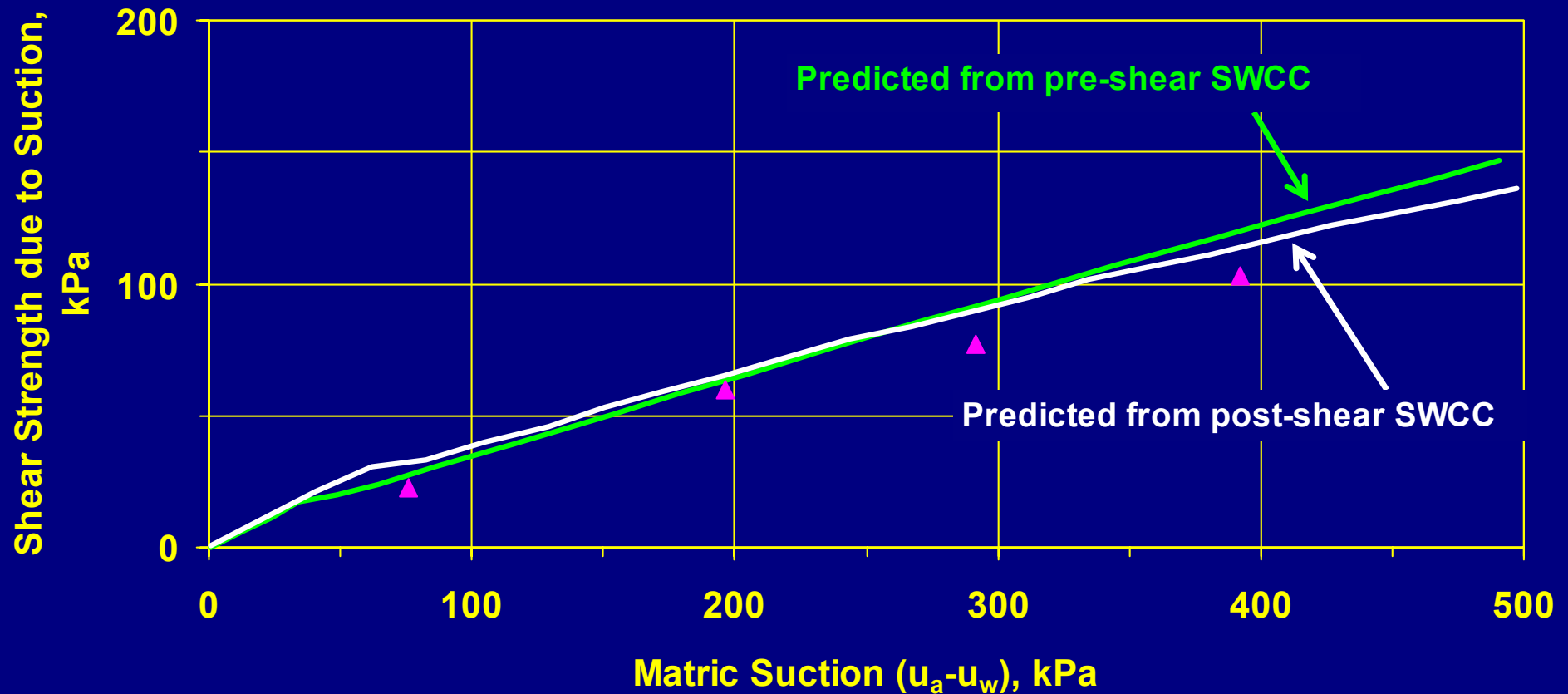

Measured and Predicted Shear Strength of Dhanauri clay for High Suction Range (Using Pre and Post-shear SWCC)

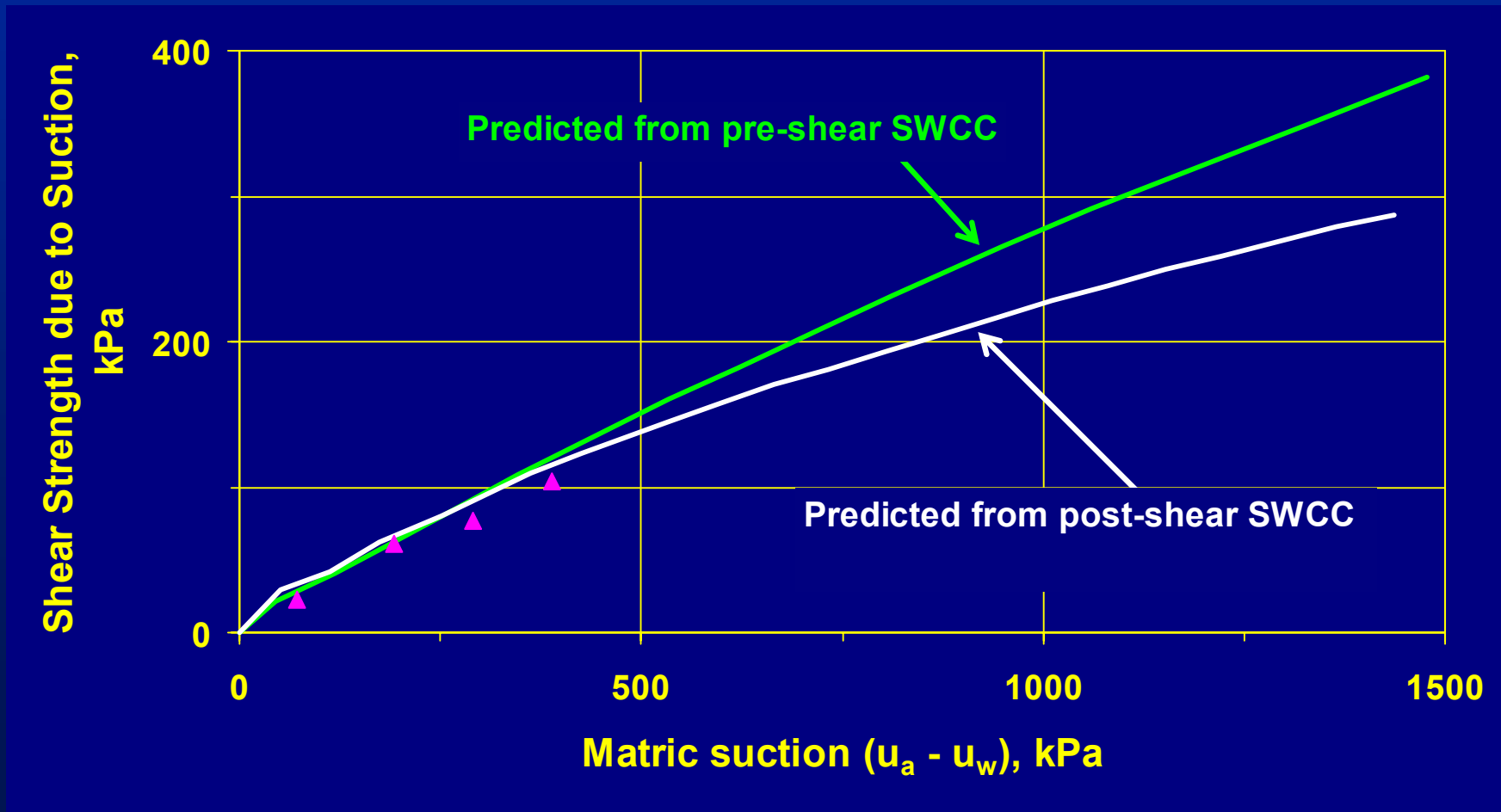

Simple Test Procedures

- **Conventional test procedures:** Unconfined compression test and Direct shear tests
- **Estimate of soil suction from simple tests?**
Based on indirection estimation:
 - Determine the degree of saturation (from volume-mass properties)
 - Use SWCC information and estimate suction for corresponding degree of saturation

Estimation of Suction from the SWCC

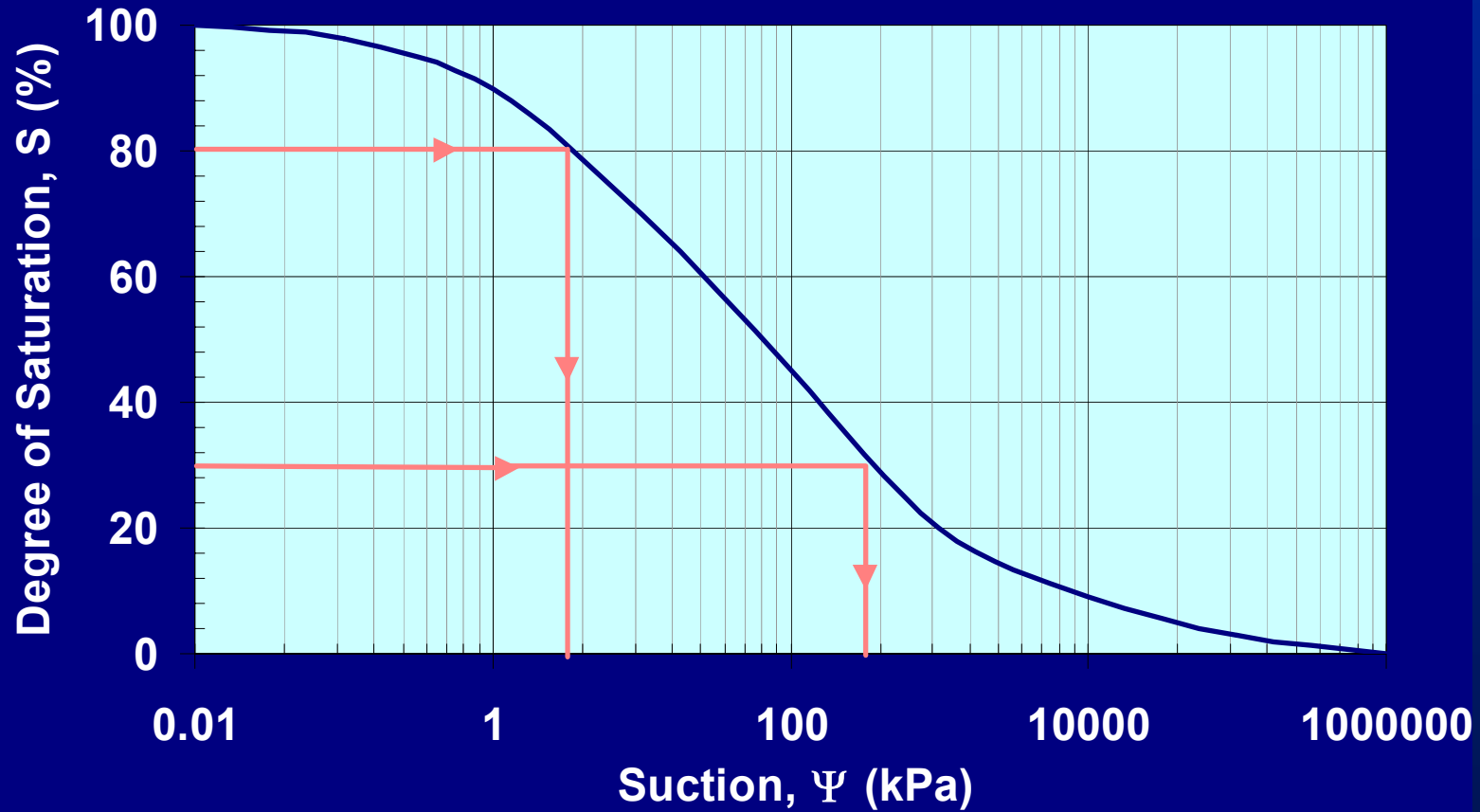

Shear Strength Interpretation from Unconfined Compression Test Results

(53rd Canadian Geotech Conf: Vanapalli et al. 2000)

- Specimen preparation for a silt specimen ($I_p = 8$)
 - statically compacted saturated specimens prepared using constant volume molds
 - air dried for varying time intervals so that fully saturated to fully dry samples would be tested
 - suctions estimated from SWCC

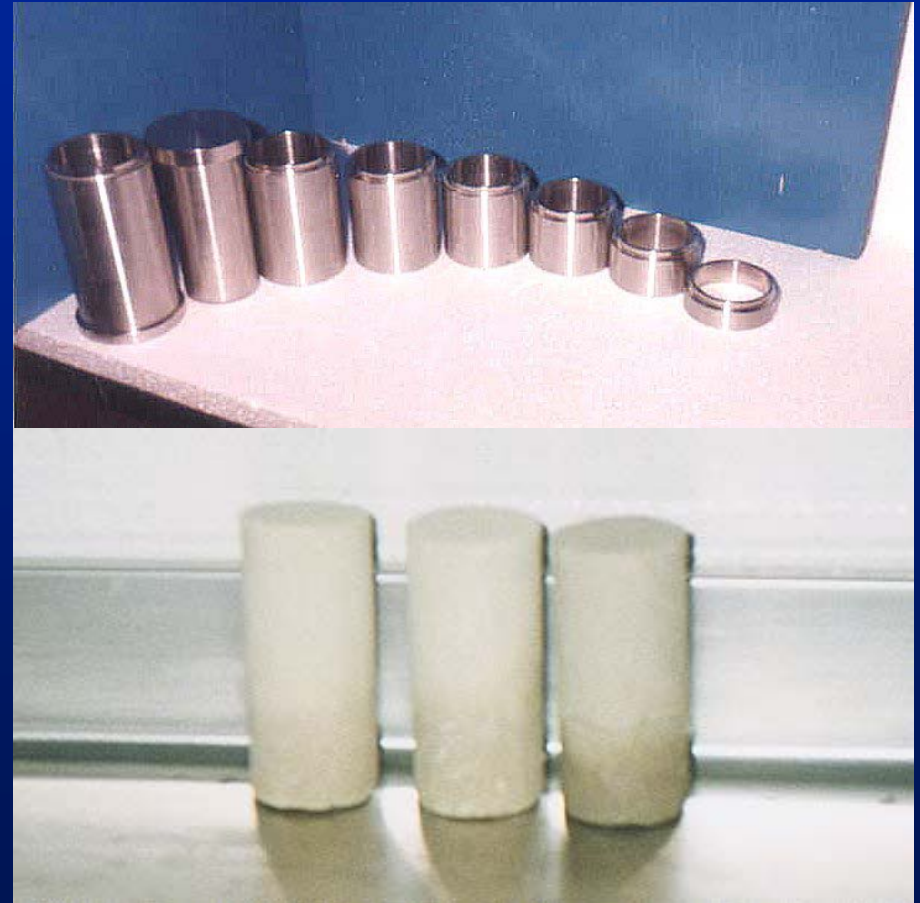

Unconfined Compression Test



- **Testing**
 - Quickly loaded at a strain rate of approx. 1.2 mm/min
 - stress readings taken at every 0.2 mm interval travel
- **Assumptions**
 - Suction in the specimen does not change during loading
 - Interpretation based on initial suction values in the specimens

Predicted and Measured Unconfined Compressive Strengths (Silt)

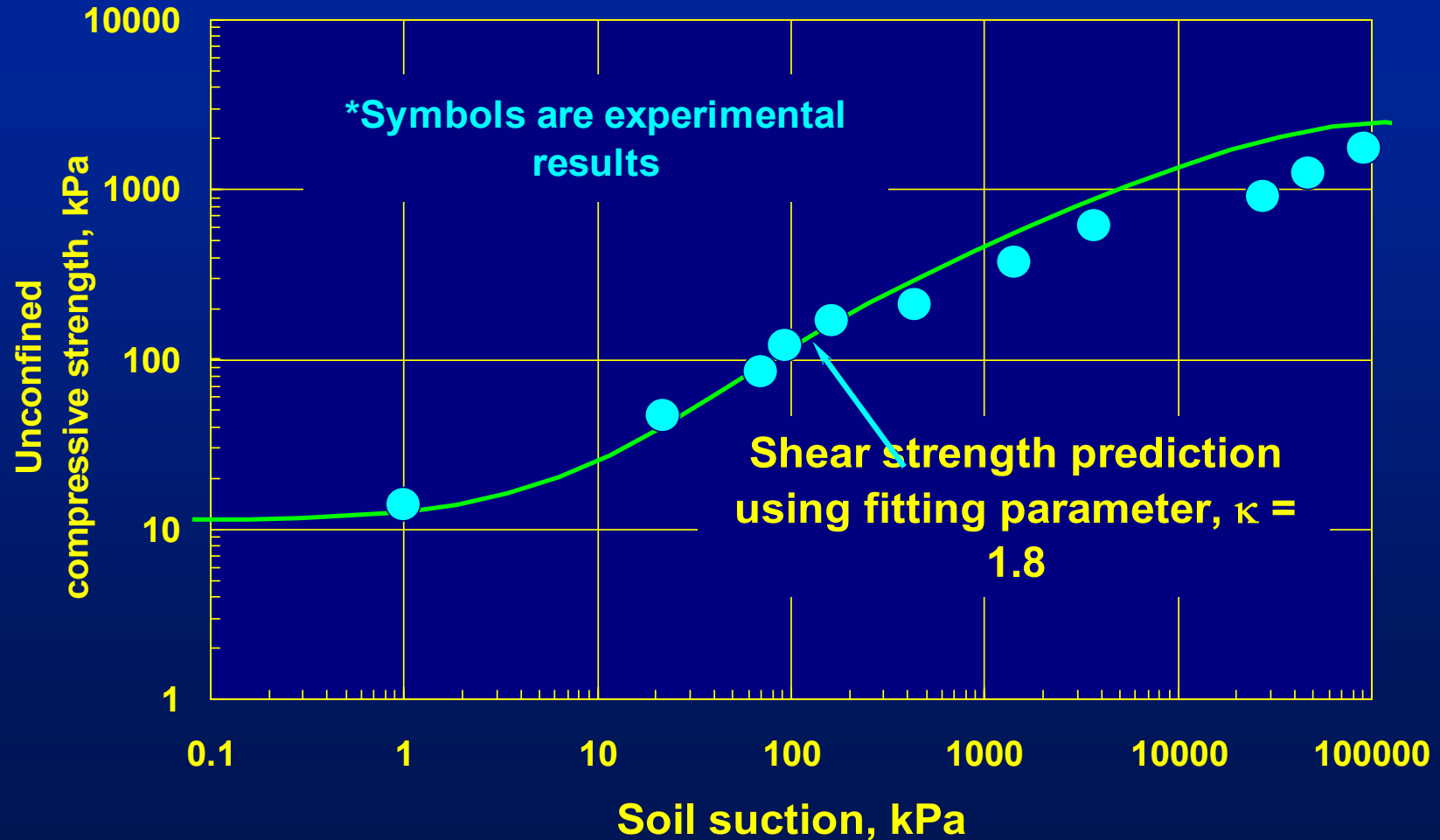

Determination of Shear Strength of Compacted Till Using Conventional Direct Shear Apparatus (Vanapalli & Lane 2002)

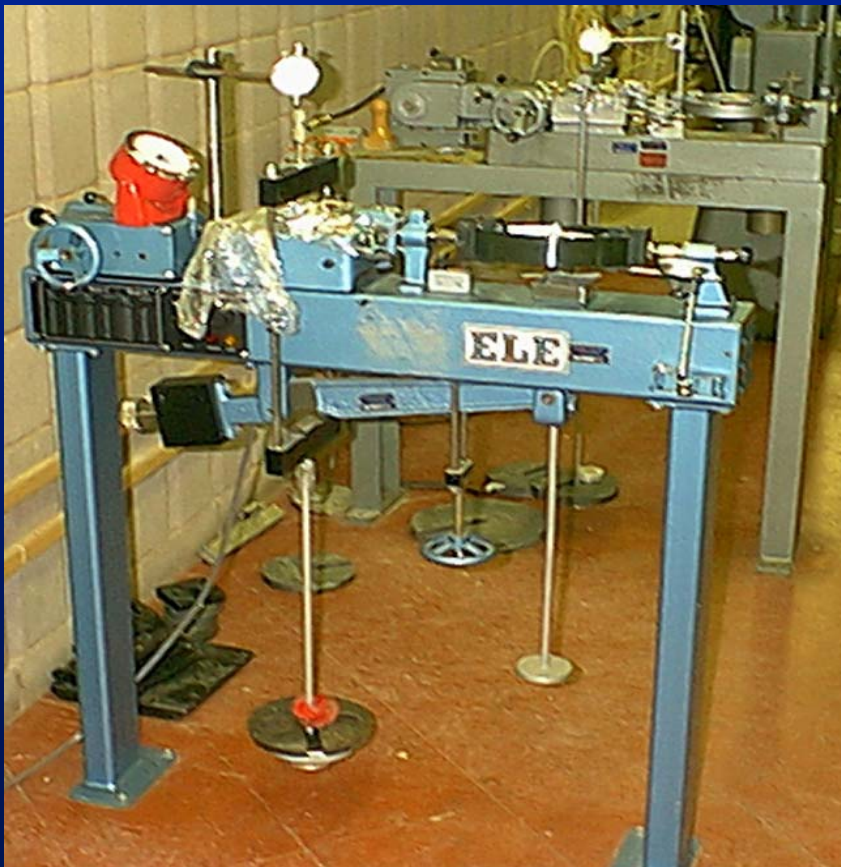

- **Shear strength of Indian Head till**
 - Three different compaction water contents
 - Provide comparisons between CDST and MDST
- **Assumption**
 - Suction in the specimen does not change during loading

Compacted Soil Specimen Extraction from Constant Volume Mould

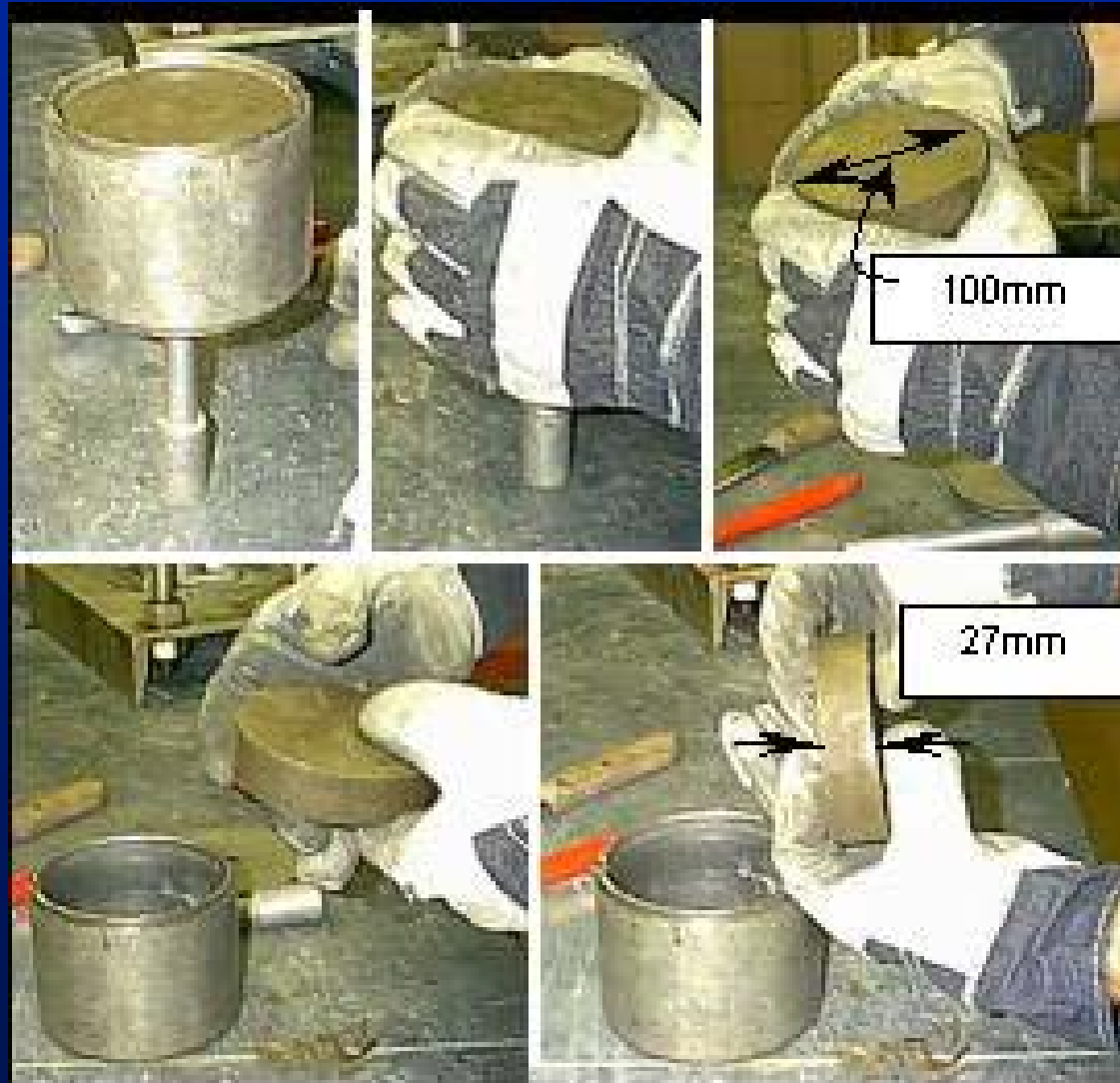

Soil Specimen Saturation Procedure



Soil Specimen & Cutter

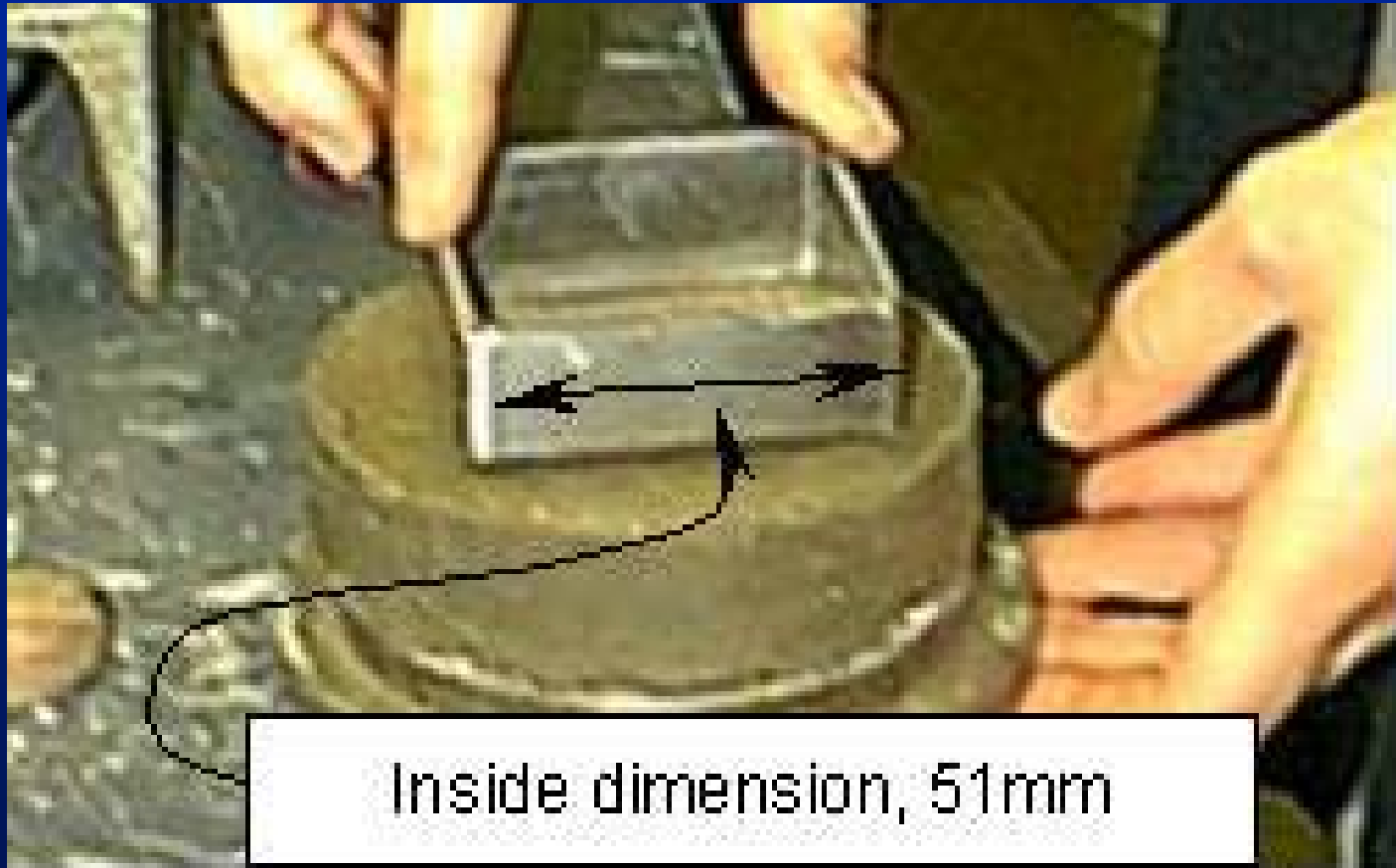

Comparison between Shear Strength Test Results Using MDST and CDST (Vanapalli & Lane 2002)

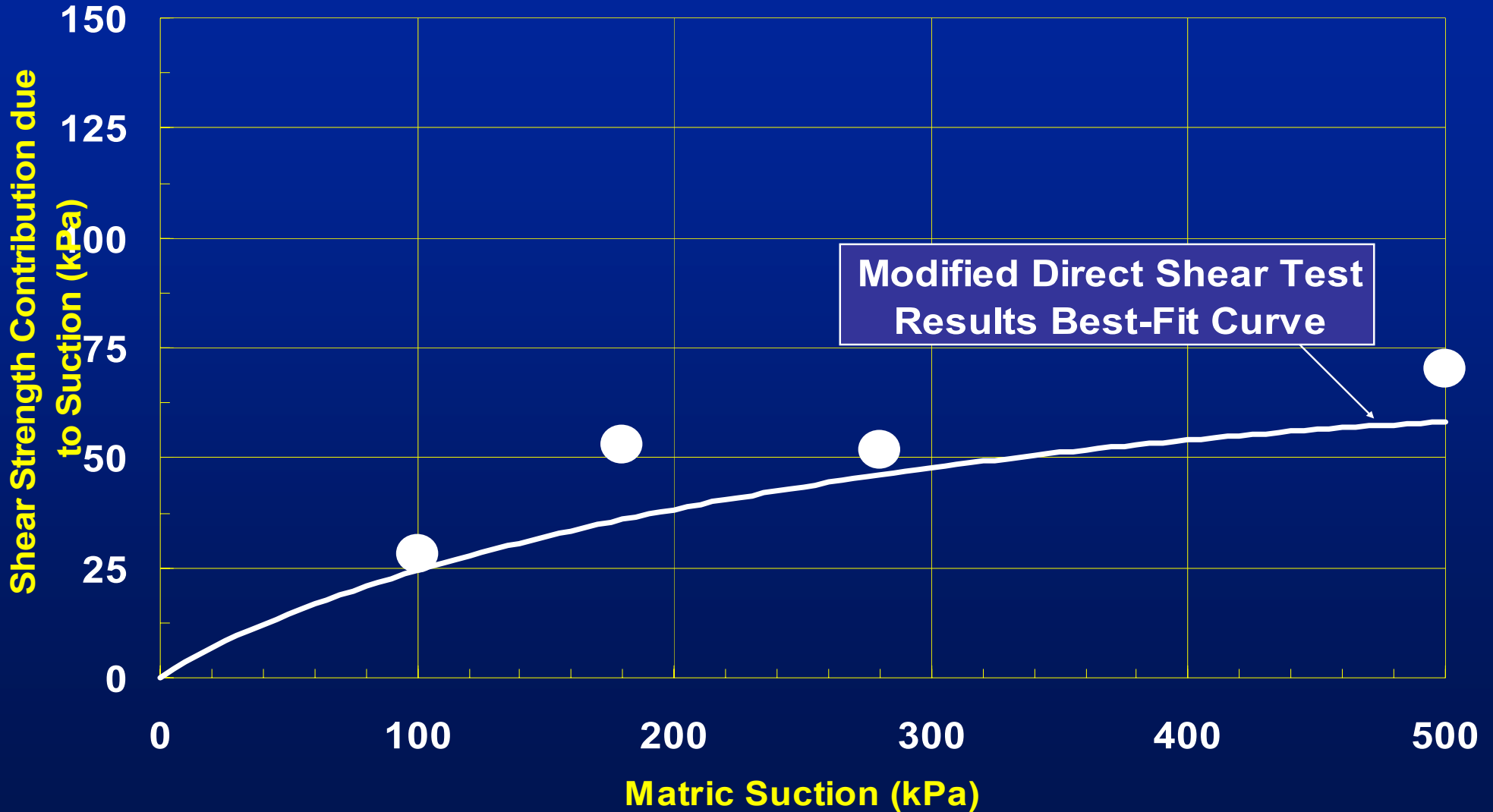

***Coefficient of Permeability of
Unsaturated Soils***

Relationship Between the SWCC and Coefficient of Permeability

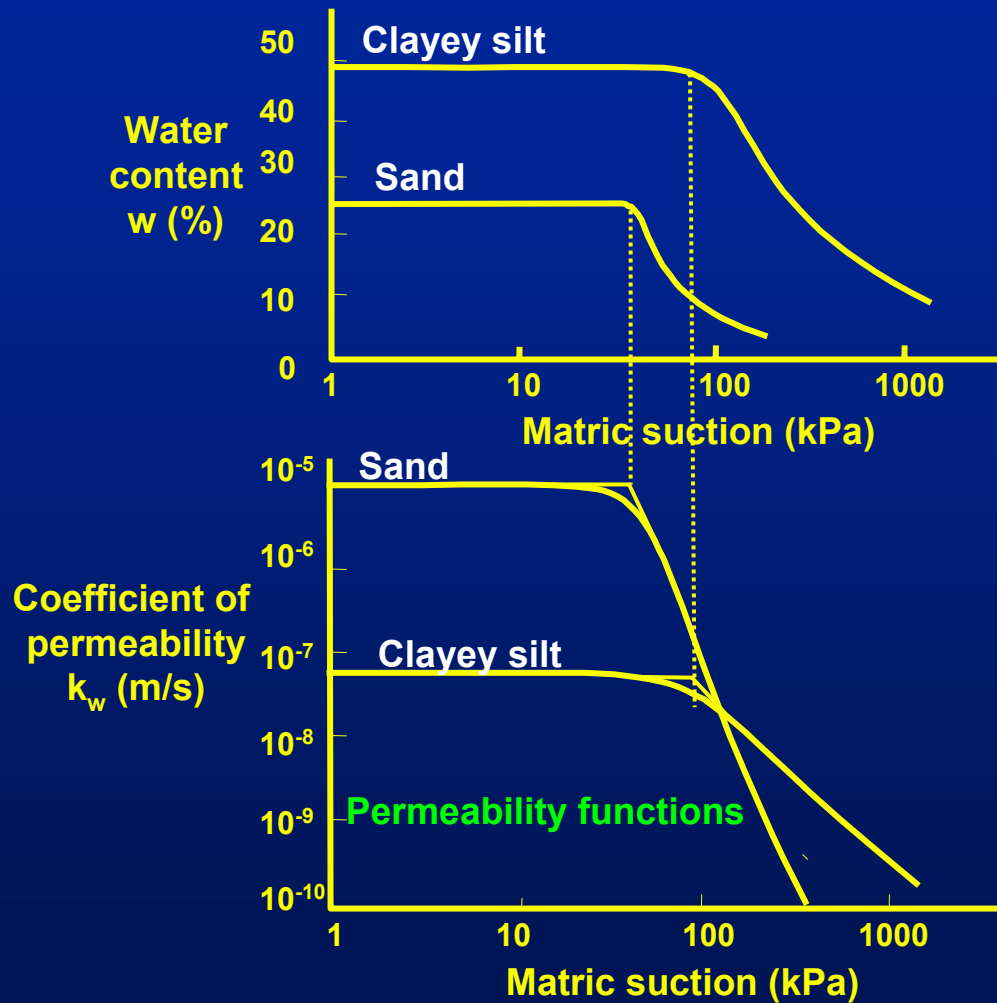

Predicting the Unsaturated Coefficient of Permeability of Soils

- Several procedures available in the literature
- **Key information:** SWCC and k_{sat}
- Several parameters influence the SWCC and the k_{unsat} :
 - applied stress
 - compaction energy
 - soil structure (function of initial compaction water content) (**important particularly in fine-grained soils**)

Normalization Technique for Estimating the Coefficient of Permeability of Unsaturated Soils

- Time consuming and expensive to measure SWCC taking into account the influence of parameters such as the stress state and soil structure
- Useful to the practicing engineers if a simple technique can be proposed.
- Relative or the normalized coefficient of permeability, $k_{rel} = k_{unsat}/k_{sat}$

Comparison of k_{rel} and S for a Typical Sand and Clay Loam

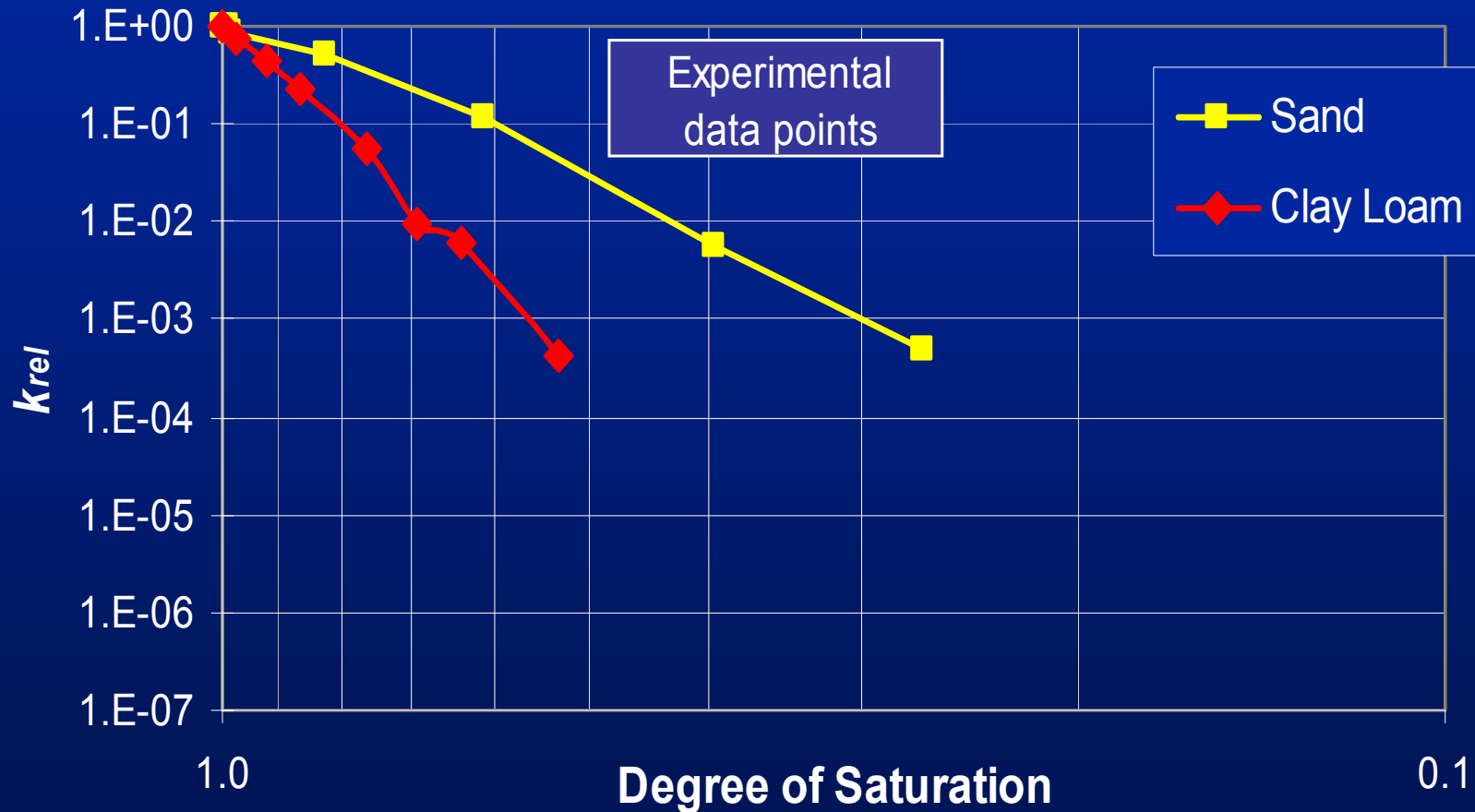

k_{rel} versus S Using Different γ Values

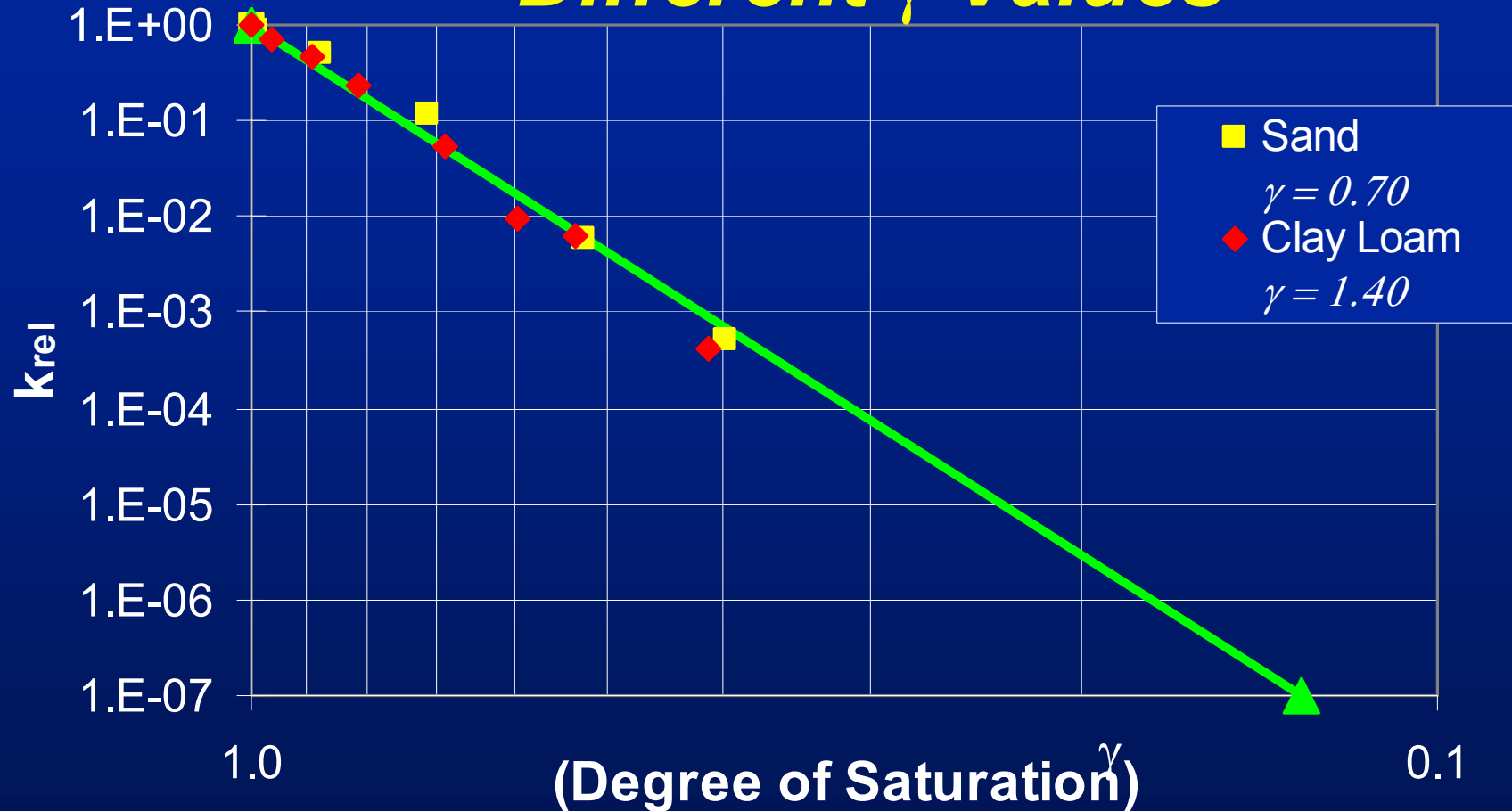

- Unique trend line for both the soils: Sand and Clay Loam through the use of different fitting parameter, γ values

k_{rel} versus S_r^γ for Touchet Silt Loam

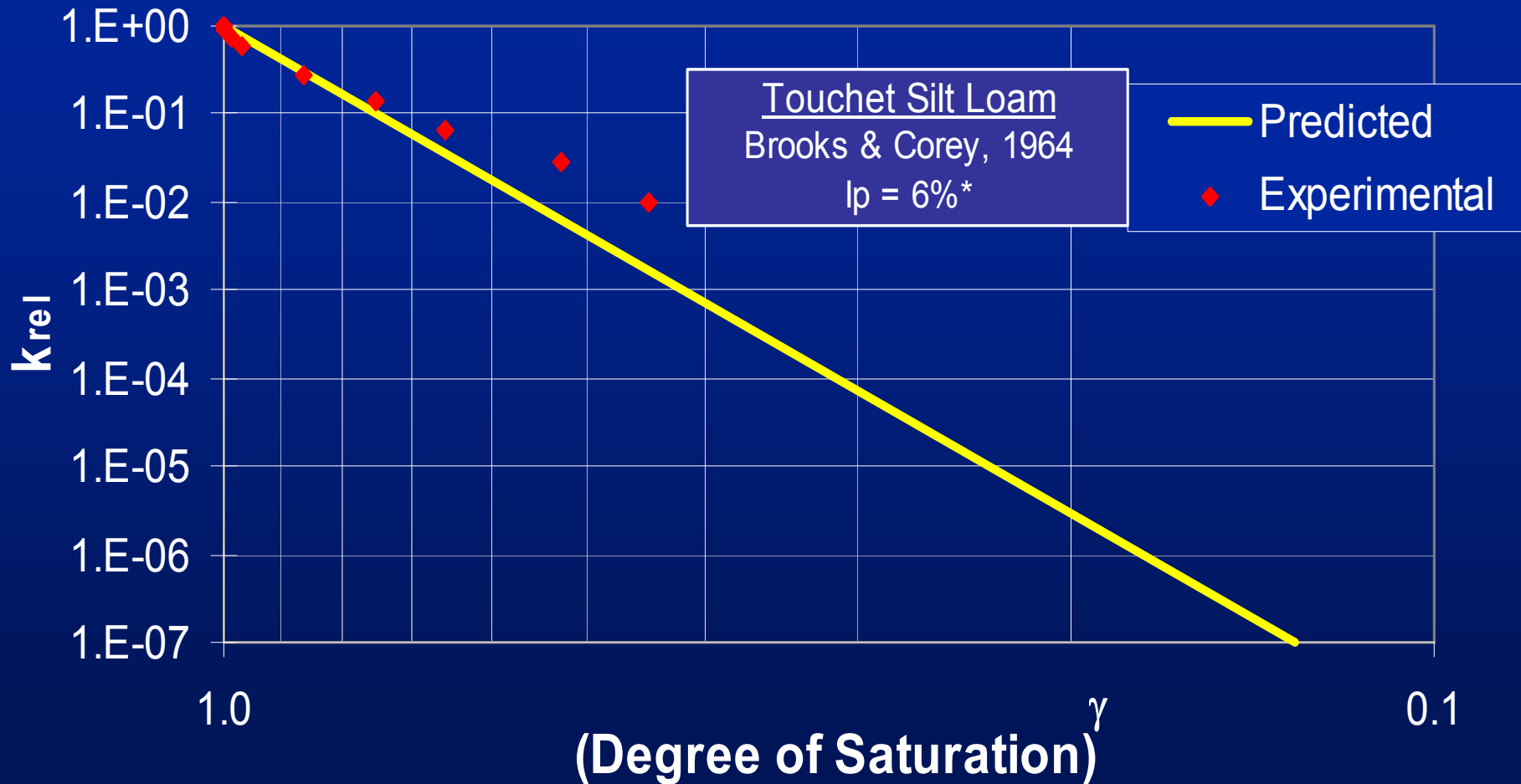

k_{rel} versus S^γ for Yolo Light Clay

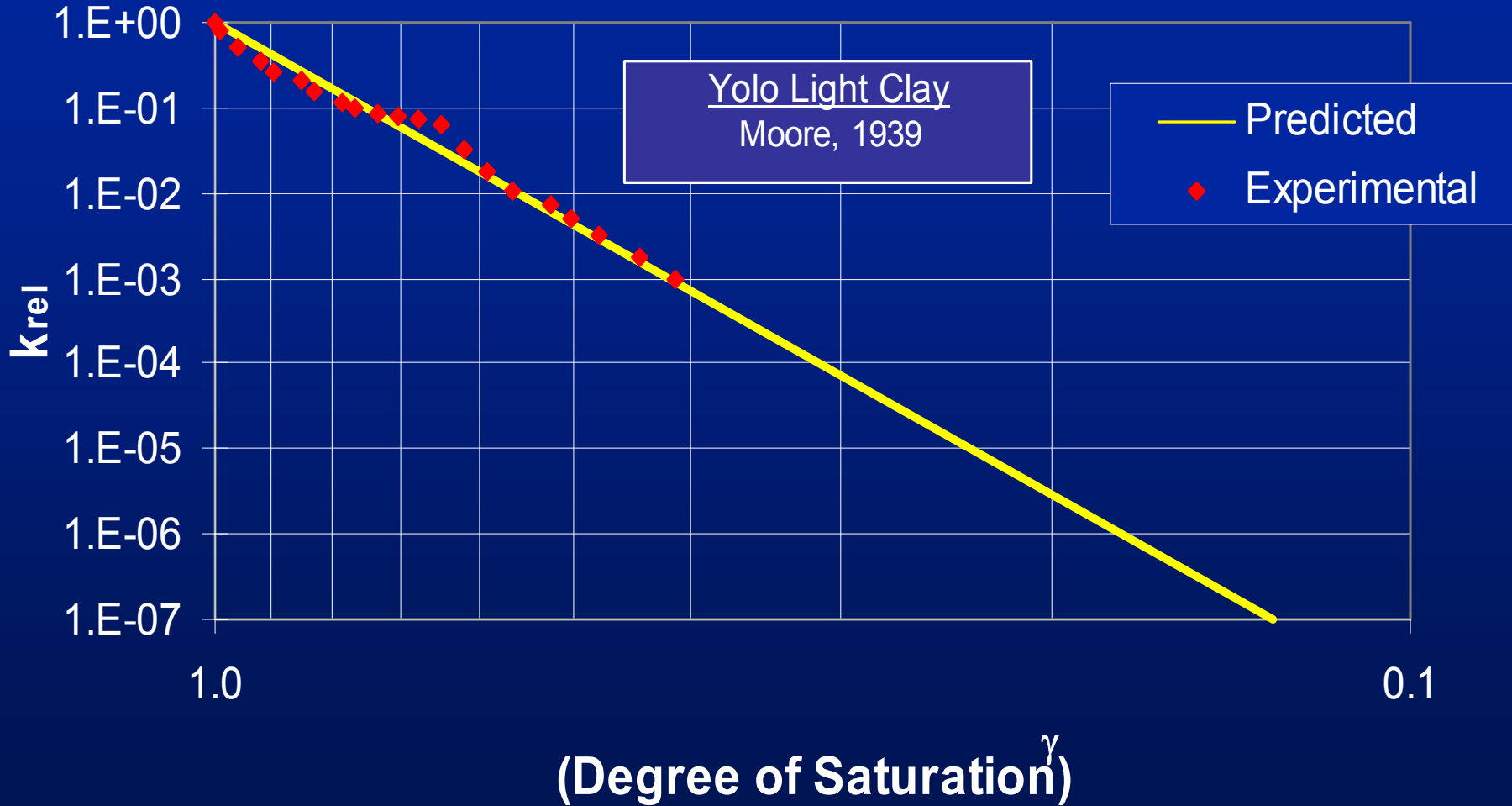

Influence of Stress State on the k_{rel} versus S^γ Relationship (Silt)

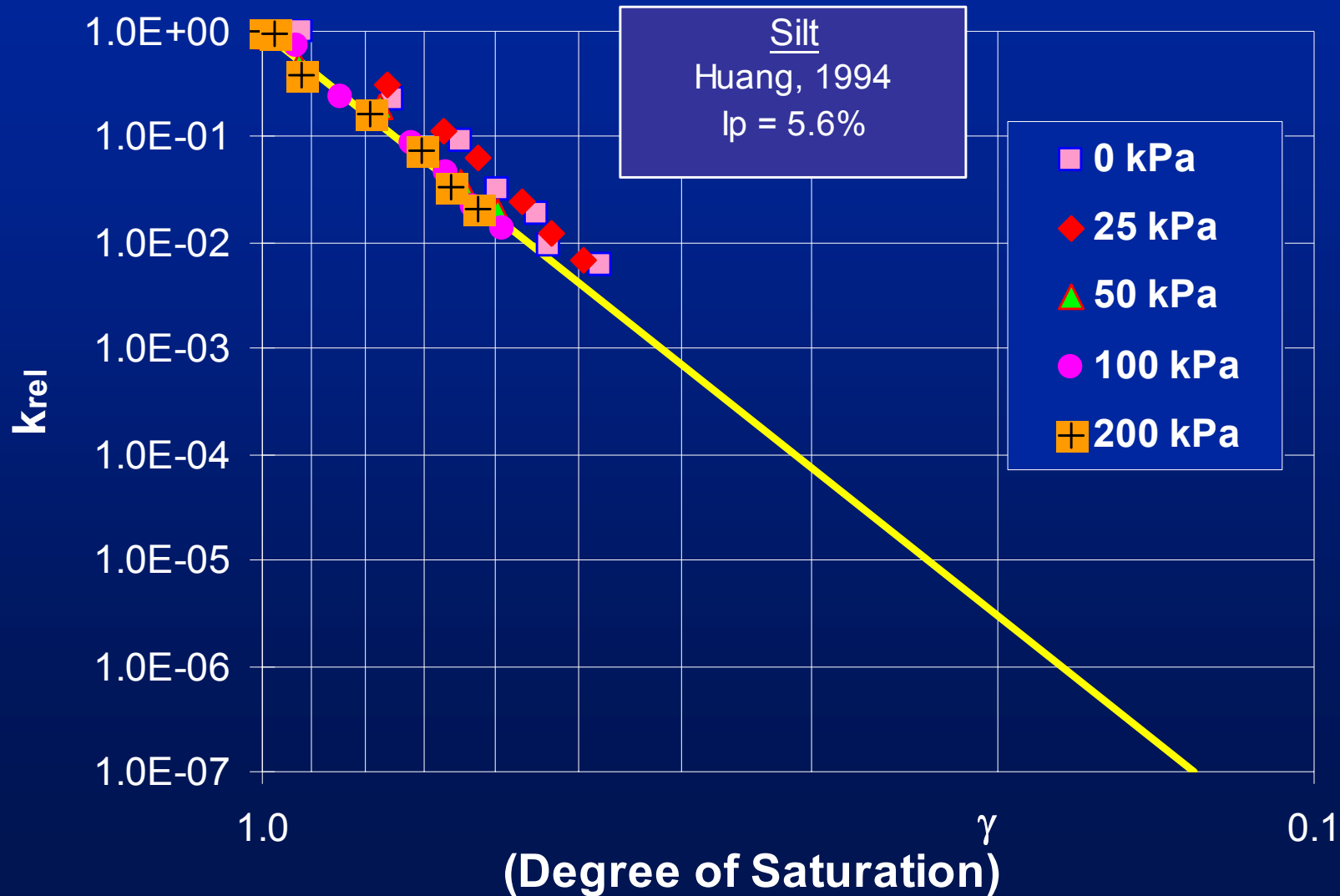

k_{rel} versus S^{γ} for soils (Using Brooks & Corey 1964 Results)

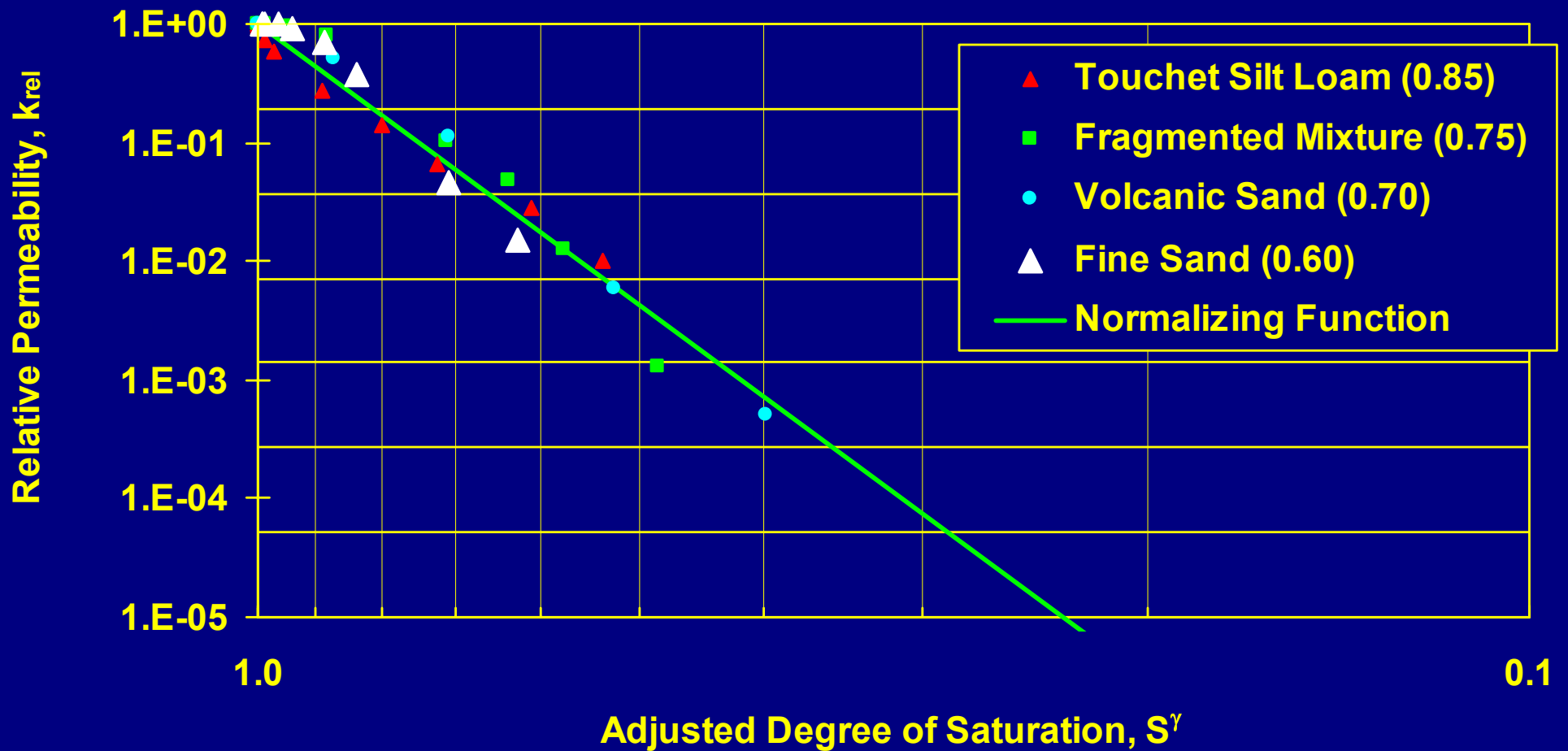

k_{rel} versus S^{γ} wetting & drying for London Clay (Croney & Coleman, 1954)

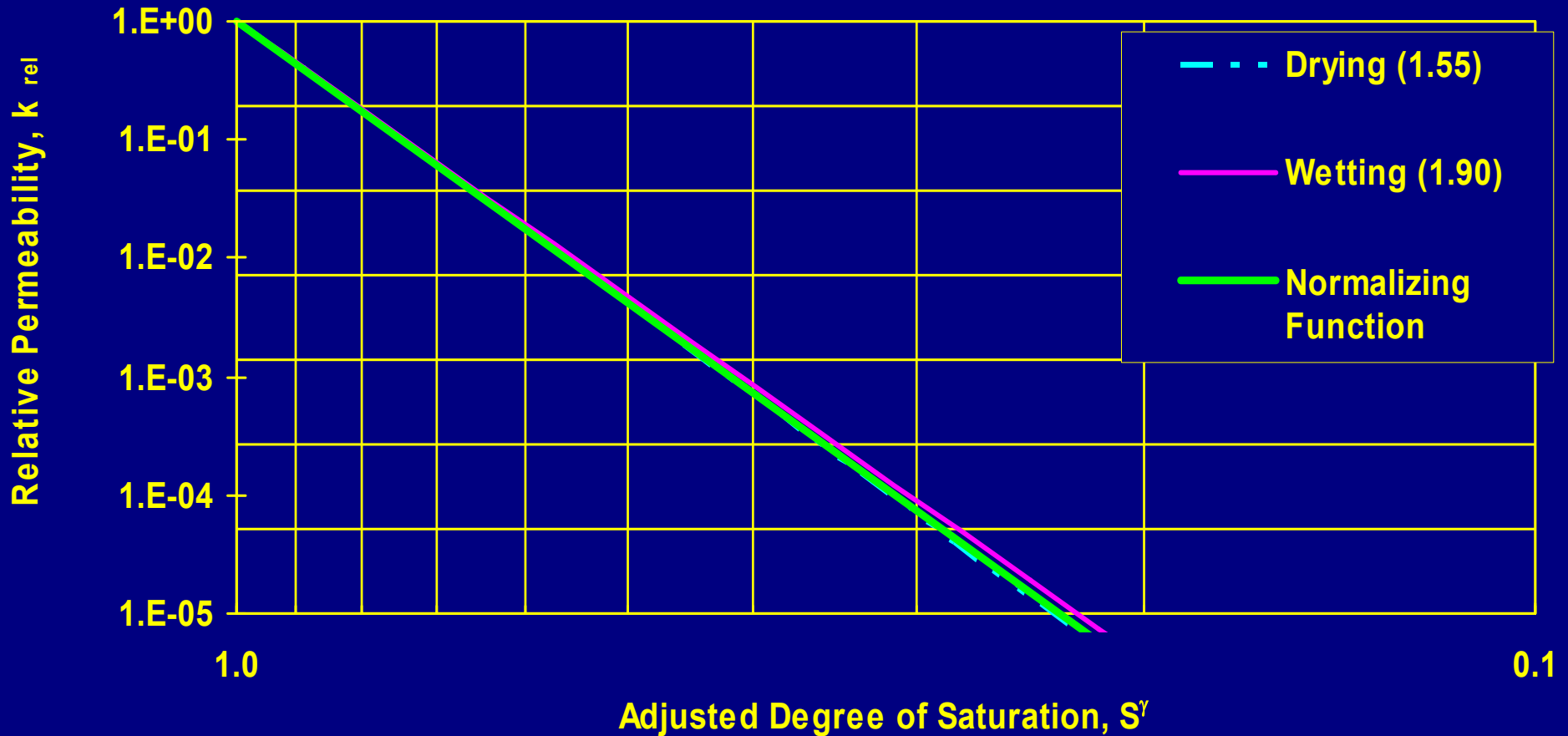

The Relationship Between the k_{rel} versus S^γ

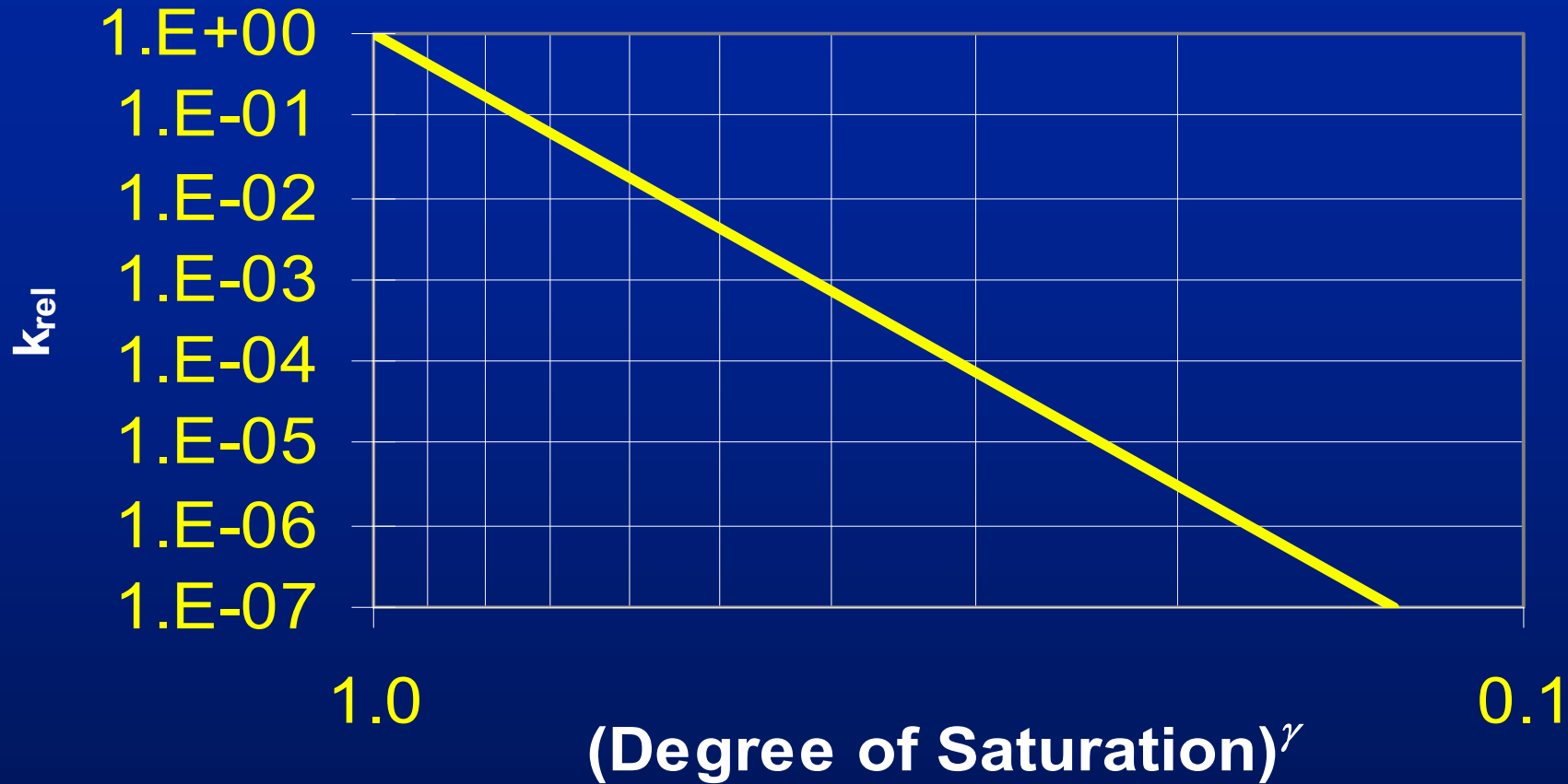

$$k_{rel} \approx S^{7.9\gamma}$$

where:

$$k_{rel} = k_{unsat}/k_{sat}$$

Relationship between Fitting Parameter γ and Plasticity Index, I_p

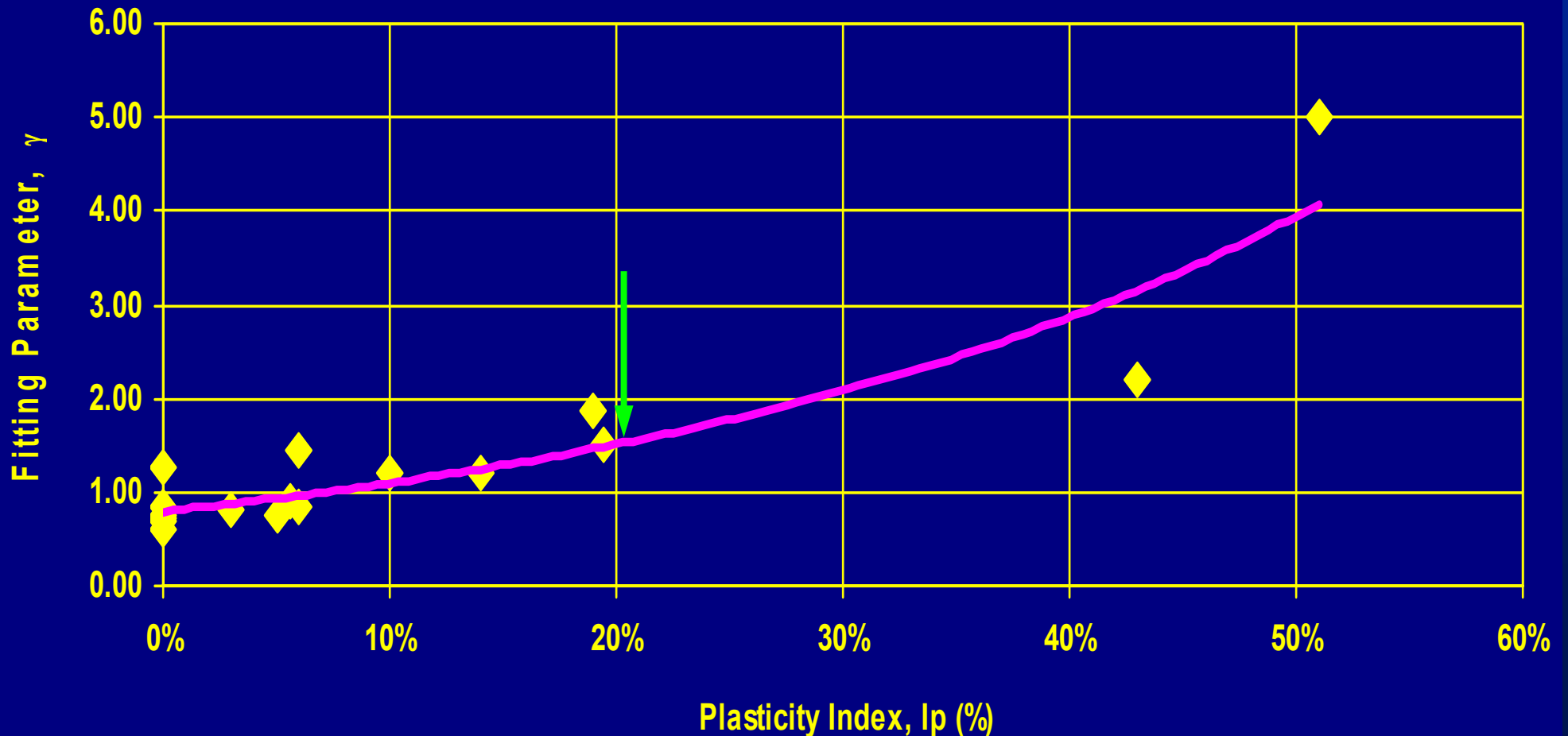

Estimation of Unsaturated Coefficient of Permeability

- The coefficient of permeability can be estimated using the simple function.

$$k_{rel} \approx S^{7.9\gamma}$$

- Required information: Saturated coefficient of permeability, k_{sat} , Water content, w or the degree of saturation, S , and the plasticity index, I_p .
- More studies are in progress to test the validity and the limitations of the proposed simple function.

Summary

- SWCC can be used as a tool to propose simple estimation techniques for interpreting the engineering behavior of unsaturated soils.
- SWCC can be measured using centrifuge techniques reliably in a relatively shorter period of time compared to conventional procedures.
- The engineering properties of unsaturated soils can be estimated using simple techniques with the aid of conventional experimental results.
- These studies are useful to extend the principles of unsaturated soils into engineering practice such as the design of pavements

Thank you,



Sai Vanapalli
August 5, 2002